

1-1 Product Overview

1-1-1 Overview

The MN101C00 series of 8-bit single-chip microcomputers incorporate several types of peripheral functions. This chip series is well suited for VCR, MD, TV, CD, LD, printer, telephone, home automation, pager, air conditioner, PPC, remote control, fax machine, musical instrument, and other applications.

The MN101C01D has an internal 64 KB of ROM and 2,048 bytes of RAM. Peripheral functions include six sets of timers, three sets of serial interfaces, an A/D converter, and remote control output. The configuration of this microcomputer is well suited for applications as a system controller in a VCR selection timer, CD player, MD, or portable terminal.

With two oscillation systems (max. 20 MHz/32 kHz) contained on the chip, the system clock can be switched between high and low speed. An automatic data transfer function (ATC) that is activated by interrupts, allows highly efficient interrupt processing.

When the oscillation source (fosc) is 8 MHz, a machine cycle lasts for 250 ns. When fosc is 20 MHz, a machine cycle is 100 ns. The package is a 80-pin QFS.

1-1-2 Product Summary

This manual describes the following models of the MN101C01 series. These products have identical functions.

Table 1-1-1 Product Summary

Model	ROM Size	RAM Size	Classification
MN101C01A*	32 KB	1,536 bytes	Mask ROM version
MN101C01C	48 KB	2,048 bytes	Mask ROM version
MN101C01D	64 KB	2,048 bytes	Mask ROM version
MN101CP01D	64 KB	2,048 bytes	EPROM version

* Under development

1-2 Hardware Functions

ROM/RAM Size:	<p><Single chip mode></p> <p>Internal ROM*² 65,536×8-bit</p> <p>Internal RAM*² 2,048×8-bit</p> <p><Memory expansion mode></p> <p>Internal ROM*² 65,536×8-bit</p> <p>Internal RAM*² 2,048×8-bit</p> <p>External ROM 128K×8-bit</p> <p>External RAM 4K×8-bit</p> <p><Processor mode></p> <p>Internal ROM Unused</p> <p>Internal RAM*² 2,048×8-bit</p> <p>External ROM 240K×8-bit</p> <p>External RAM 4K×8-bit</p>
Machine Cycles:	<p>High speed mode 0.10μs/20MHz (4.5V~5.5V)</p> <p>0.25μs/8MHz(2.7V~5.5V)</p> <p>1.00μs/2MHz(2.0V~5.5V)</p> <p>Low speed mode 125μs/32KHz(2.0V~5.5V)</p>
Interrupts:	<p>17 interrupts</p> <p><External interrupts></p> <p>The active edge can be selected for all external interrupts</p> <p>IRQ0 External interrupt (can be connected to noise filter)</p> <p>IRQ1 External interrupt (can determine zero crossings, can be connected to noise filter)</p> <p>IRQ2 External interrupt (synchronous output event)</p> <p>IRQ3 External interrupt</p> <p>IRQ4 External interrupt (dual function for key interrupts)</p> <p><Timer interrupts></p> <p>TM0IRQ Timer 0 (8-bit timer)</p> <p>TM1IRQ Timer 1 (8-bit timer)</p> <p>TM2IRQ Timer 2 (8-bit timer)</p> <p>TM3IRQ Timer 3 (8-bit timer)</p> <p>TM4IRQ Timer 4 (16-bit timer)</p> <p>TM5IRQ Timer 5 (8-bit timer)</p> <p>TBIRQ Clock timer interrupts</p> <p><Serial communication interrupt></p> <p>SC0IRQ Serial 0 (synchronous + simple UART)</p> <p>SC1IRQ Serial 1 (synchronous)</p> <p>SC2IRQ Serial 2 (synchronous + simple IIC)</p> <p><Automatic transfer complete interrupt></p> <p>ATCIRQ-Automatic transfer complete</p>

*2 Differs depending upon the model.
[Ref: 1-1-2 "Product Summary"]

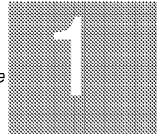

<A/D conversion complete interrupt>

ADIRQ A/D conversion complete

<Runaway interrupt>

NMI Overflow of watchdog timer

Automatic transfer: Activated by each type of interrupt

Dedicated 1 word transfers between memory and peripheral function block

Variable data length up to 256 bytes

Timer/Counters:	seven timers, all can generate interrupts
	<p>Timer 0 8-bit timer</p> <p>Square wave output and 8-bit PWM output are possible.</p> <p>Clock source: f_{osc}, f_s, $f_s/4$, TM0IO pin input</p> <p>Can generate remote control carrier</p> <p>Timer 1 8-bit timer</p> <p>Square wave output and synchronous output event</p> <p>Clock source: $f_s/16$, $f_s/64$, f_x, TM1IO pin input</p> <p>Timers 0 and 1 may be cascaded.</p> <p>Timer 2 8-bit timer</p> <p>Square wave output, 8-bit PWM output are possible, and synchronous output event.</p> <p>Clock source: f_s, $f_s/4$, f_x, TM2IO pin input</p> <p>Timer 3 8-bit timer</p> <p>Square wave output, synchronous serial/UART baud rate timer</p> <p>Clock source: f_{osc}, $f_s/4$, $f_s/16$, TM3IO pin input</p> <p>Can generate remote control carrier</p> <p>Timers 2 and 3 can be cascaded.</p> <p>Timer 4 16-bit timer</p> <p>Square wave output, 16-bit PWM output are possible, and synchronous output event.</p> <p>Clock source: f_{osc}, $f_s/4$, $f_s/16$, TM4IO pin input</p> <p>Input capture function</p> <p>Time base timer</p> <p>Clock source: f_{osc}, $f_s/4$, f_x, $f_x/2^{13}$ or $f_{osc}/2^{13}$</p> <p>XIO at 32kHz, can be set to measure one minute intervals</p> <p>Can operate independently as timer 5 (8-bit timer).</p> <p>Watchdog timer</p> <p>Selected by the mask option as $f_{osc}/2^{17}$, $f_{osc}/2^{19}$, or $f_{osc}/2^{21}$</p>
Synchronous output function:	The set value in output from port 7 in synchronization with the overflow of timer 1, timer 2, or timer 4, or at the edge of transition of IRQ2.
Remote control carrier output:	Based on the timer output, a remote control carrier with duty ratio of 1/2, 1/3 can be output.
Buzzer output:	Output frequency can be selected from $f_s/2^9$, $f_s/2^{10}$, $f_s/2^{11}$, or $f_s/2^{12}$

Serial interface: 3 channels

- CH0 Synchronous/ Simple UART (half-duplex)
 - Transfer clock: $fs/2$, $fs/4$, $fs/16$, $1/2$ of timer 3 output
 - When using timer 3, the transfer rates for a 12MHz oscillation are 19200/9600/4800/2400/1200/300 bps.
 - MSB or LSB can be selected as the first bit for transfer. An arbitrary transfer size of 1~8 bits can be selected.
- CH1 Synchronous
 - Transfer clock: $fs/2$, $fs/8$, $fs/64$, $1/2$ of timer 3 output
 - MSB or LSB can be selected as the first bit for transfer. An arbitrary transfer size of 1~8 bits can be selected.
- CH2 Synchronous
 - Transfer clock: fs , $fs/2$, $fs/4$, $1/2$ of timer 0 output
 - MSB or LSB can be selected as the first bit for transfer. An arbitrary transfer size of 1~8 bits can be selected.
 - Simple IIC communication is possible (with a single master)

A/D converter: 10 bits \times 8 channels

LED driver function: 8 pins

Ports:

- I/O ports 57 ports (57 have dual functions)
 - LED (large current) driver ports: 8 ports (push-pull configuration)
 - Number of pins with dual function for external expansion mode: 30
- Input ports 13 ports (all have dual functions)
 - Number of pins with dual function for external interrupts: 5 (One of which can also be used for zero-cross input.)
 - Number of pins with dual function for A/D input: 8
 - Analog reference voltage input pins: 2
 - Operation mode input pin: 1
 - Reset input pin: 1

Operation modes: NORMAL mode
 SLOW mode
 HALT mode
 STOP mode
 and switches operating clock

Package: 80-pin QFS

1-3 Pins

1-3-1 Pin Diagram

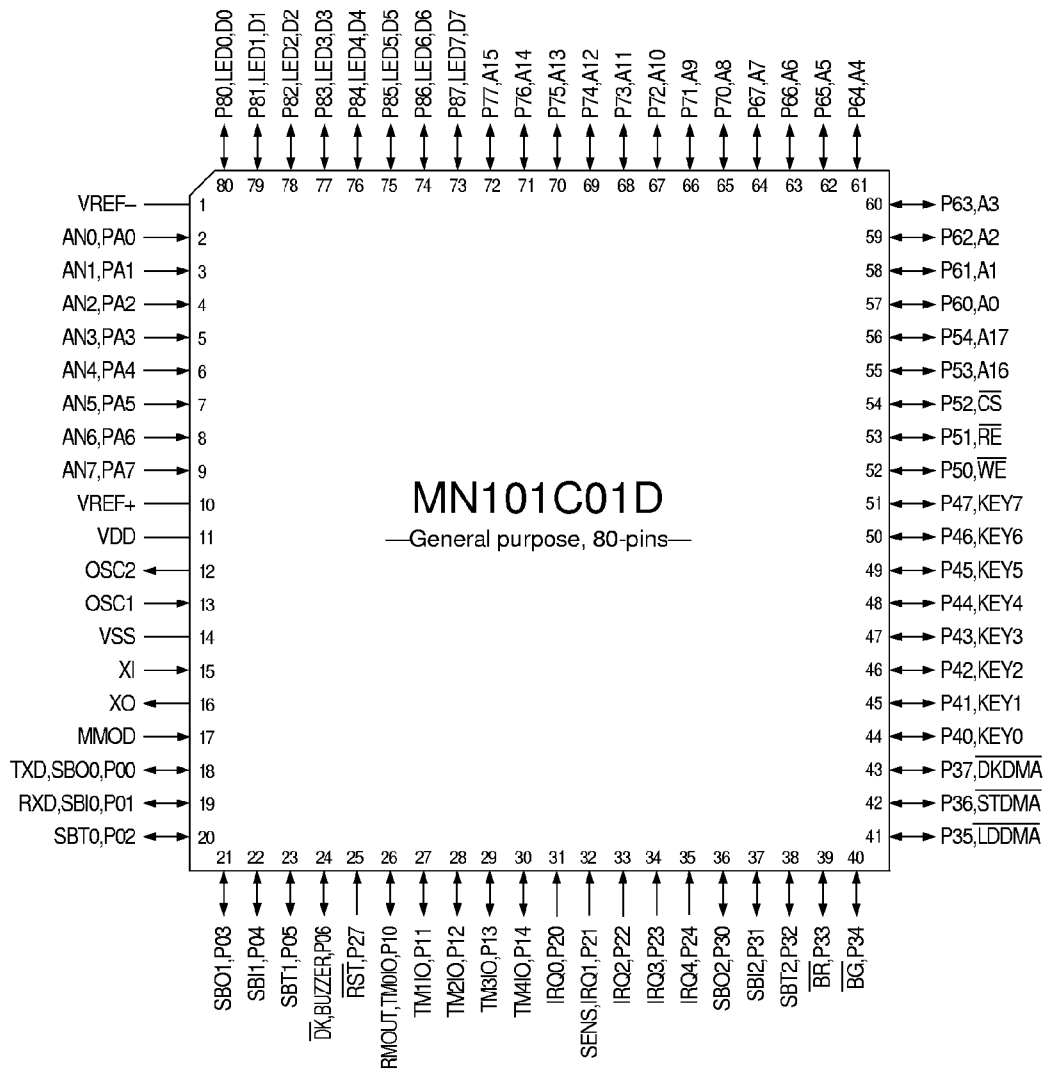

Figure 1-3-1 Pin Diagram (80QFS: top view)

1-3-2 Pin Function Summary

Table 1-3-1 Pin Function Summary (1/5)

Pin No.	Name	Type	Dual Function	Function	Description
14 11	VSS VDD	–		Power supply pins	Apply 2.0V~5.5V to VDD and 0V to VSS.
13 12	OSC1 OSC2	Input Output		Clock input pin Clock output pin	Connect these oscillation pins to ceramic or crystal oscillators for high-speed clock operation. If the clock is an external input, connect it to OSC1 and leave OSC2 open. The chip will not operate with an external clock when using either the STOP or SLOW modes.
15 16	XI XO	Input Output		Clock input pin Clock output pin	Connect these oscillation pins to ceramic or crystal oscillators for low-speed clock operation. If the clock is an external input, connect it to XI and leave XO open. The chip will not operate with an external clock when using the STOP mode. If these pins are not used, connect XI to VSS and leave XO open.
25	RST	I/O	P27	Reset pin	This pin resets the chip when power is turned on, is allocated as P27 and contains an internal pull-up resistor (Typ. 50 kΩ). Setting this pin low initializes, the internal state of the device. Thereafter, setting the input to an "H" level, releases the reset. The hardware waits for the system clock to stabilize, and then processes the reset interrupt. Also, if "0" is written to P27 and the reset is initiated by software, a low level will be output. The output has an n-channel open-drain configuration. If a capacitor is to be inserted between $\overline{\text{RST}}$ and VDD, it is recommended that a discharge diode be placed between $\overline{\text{RST}}$ and VDD.
18~24	P00~P06	I/O	SBO0(TXD), SB10(RXD), SBT0, SBO1, SB11, SBT1, $\overline{\text{DK}}$ (BUZZER)	I/O port 0	7-bit CMOS tri-state I/O port. Each bit can be set individually as either an input or output by the P0DIR register. A pull-up resistor for each bit can be selected individually by the P0PLU register. At reset, the input mode is selected and pull-up resistors are disabled (high impedance output).

Table 1-3-1 Pin Function Summary (2/5)

Pin No.	Name	Type	Dual Function	Function	Description
26~30	P10~P14	I/O	TM0IO (RMOUT), TM1IO~ TM4IO	I/O port 1	5-bit CMOS tri-state I/O port. Each bit can be set individually as either an input or output by the P1DIR register. A pull-up resistor for each bit can be selected individually by the P1PLU register. At reset, the input mode is selected and pull-up resistors are disabled (high impedance output).
31~35	P20~P24	Input	IRQ0, IRQ1(SENS), IRQ2~4	Input port 2	5-bit input port. A pull-up resistor for each bit can be selected individually by the P2PLU register. At reset, the input mode is selected and pull-up resistors are disabled (high impedance output).
25	P27	Input	\overline{RST}	Input port 2	Port P27 has an n-channel open-drain configuration. When "0" is written and the reset is initiated by software, a low level will be output.
36~43	P30~P37	I/O	SBO2 SB12 SBT2 \overline{BR} \overline{BG} \overline{LDDMA} \overline{STDMA} \overline{DKDMA}	I/O port 3	8-bit CMOS tri-state I/O port. Each bit can be set individually as either an input or output by the P3DIR register. A pull-up resistor for each bit can be selected individually by the P3PLU register. At reset, the input mode is selected and pull-up resistors are disabled (high impedance output).
44~51	P40~P47	I/O	KEY0~7	I/O port 4	8-bit CMOS tri-state I/O port. Each bit can be set individually as either an input or output by the P4DIR register. A pull-up resistor for each bit can be selected individually by the P4PLU register. At reset, the input mode is selected and pull-up resistors are disabled (high impedance output).
52~56	P50~P54	I/O	\overline{WE} , \overline{RE} , \overline{CS} , A16, A17	I/O port 5	5-bit CMOS tri-state I/O port. Each bit can be set individually as either an input or output by the P5DIR register. A pull-up resistor for each bit can be selected individually by the P5PLU register. At reset, when single chip mode is selected, the input mode is selected and pull-up resistors for P50~P54 are disabled (high impedance output). During processor mode, \overline{WE} , \overline{RE} , \overline{CS} , A16, and A17 are selected.
57~64	P60~P67	I/O	A0~A7	I/O port 6	8-bit CMOS tri-state I/O port. Each bit can be set individually as either an input or output by the P6DIR register. A pull-up resistor for each bit can be selected individually by the P6PLU register. At reset, when single chip mode is selected, the input mode is selected and pull-up resistors for P60~P67 are disabled (high impedance output). During processor mode, output mode is selected for A0~A7.

Table 1-3-1 Pin Function Summary (3/5)

Pin No.	Name	Type	Dual Function	Function	Description
65~72	P70~P77	I/O	A8~A15	I/O port 7	<p>8-bit CMOS tri-state I/O port.</p> <p>Each individual bit can be switched to an input or output by the P7DIR register. A pull-up or pull-down resistor for each bit can be selected individually by the P7PLUD register.</p> <p>However, pull-up and pull-down resistors cannot be mixed. This port contains a synchronous output function.</p> <p>At reset, when single chip mode is selected, the input mode is selected and pull-up resistors for P70~P77 are disabled (high impedance output). During processor mode, A8~A15 (address signals) are set to output mode.</p>
73~80	P80~P87	I/O	LED0~7 (D0~D7)	I/O port 8	<p>8-bit CMOS tri-state I/O port.</p> <p>Each individual bit can be switched to an input or output by the P8DIR register. A pull-up resistor for each bit can be selected individually by the P8PLU register. When configured as outputs, these pins can drive segments.</p> <p>At reset, when single-chip mode is selected, the input mode is selected and pull-up resistors for P80~P87 are disabled (high impedance output). During processor mode, D0~D7 (data signals) are set to input mode (high-impedance output).</p>
2~9	PA0~PA7	Input	AN0~AN7	Input port A	<p>8-bit input port.</p> <p>A pull-up or pull-down resistor for each bit can be selected individually by the PAPLUD register. However, pull-up and pull-down resistors cannot be mixed.</p> <p>At reset, the PA0~PA7 input mode is selected and pull-up resistors are disabled.</p>
18 19	TXD RXD	Output Input	SBO0(P00) SBI0(P01)	UART transmit data output pin UART receive data input pin	<p>In the serial interface in UART mode, these pins are configured as the receive data input pin and transmit data output pin.</p> <p>A push-pull or n-channel open-drain configuration can be selected for TXD by the SCOMDI register.</p> <p>Pull-up resistors can be selected by the P0PLU register. The TXD and RXD pins are also allocated as P00 and P01 respectively. When not used as serial/UART pins, these can be used as normal I/O pins.</p>

Table 1-3-1 Pin Function Summary(4/5)

Pin No.	Name	Type	Dual Function	Function	Description
18 21 36	SBO0 SBO1 SBO2	Output	TXD(P00) P03 P30	Serial interface transmit data output pins	Transmit data output pins for serial interfaces 0~2. The output configuration, either CMOS push-pull or n-channel open-drain, and pull-up resistors can be selected by the software. Set these pins to the output mode by the P0DIR,P3DIR register. SBO0~2 are allocated as P00, P03, and P30. These may be used as normal I/O pins when the serial interface is not used.
19 22 37	SB10 SB11 SB12	Input	RXD(P01) P04 P31	Serial interface receive data input pins	Receive data input pins for serial interfaces 0~2. Pull-up resistors can be selected by the P0PLU and P3PLU register. Set these pins to the input mode by the P0DIR and P3DIR register. SB10~2 are allocated as P01, P04, and P31. These can be used as normal I/O pins when the serial interface is not used.
20 23 38	SBT0 SBT1 SBT2	I/O	P02 P05 P32	Serial interface clock I/O pins	Clock input pins for serial interfaces 0~2. The output configuration, either CMOS push-pull or n-channel open-drain output, can be selected by the software. From the P0DIR register, set SBT0 to the output mode and SBT1 to the input mode. The direction of SBT0~2 is selected by the P0DIR and P3DIR register in accordance with the communication mode. Pull-up resistors can be selected by the P0PLU and P3PLU register. SBT0~2 are allocated as P02, P05, and P32. These can be used as normal I/O pins when the serial interface is not used.
26	RMOUT	I/O	P10,TM0IO	Remote control transmit signal output pin	Output pin for remote control transmit signal with a carrier signal. Can be used as a normal I/O pin when remote control is not used.
26~30	TM0IO~ TM4IO	I/O	RMOUT (P10~P14)	Timer I/O pins	Event counter clock input pins, overflow pulse output pins timer 0~4 and PWM signal output pins. To use these pins as event clock inputs, configure them as inputs by the P1DIR register. For overflow pulse and PWM output, configure these pins as outputs by the P1DIR register. When the pins are used as inputs, pull-up resistors can be specified by the P1PLU register. When not used for timer I/O, these can be used as normal I/O pins.
24	BUZZER	Output	\overline{DK} (P06)	Buzzer output	Piezoelectric buzzer driver pin. The driving frequency can be selected in the range of $f_s/2^2 \sim f_s/2^{12}$ by the DLYCTR register. Select output mode by the P0DIR register and select buzzer output by the DLYCTR register. When not used for buzzer output, this pin can be used as a normal I/O pin.

Table 1-3-1 Pin Function Summary (5/5)

Pin No.	Name	Type	Dual Function	Function	Description
10 1	VREF+ VREF	–		+power supply for A/D converter –power supply for A/D converter	Reference power supply pins for the A/D converter. Normally, the values of VDD=VREF+ and VSS=VREF are used.
17	MMOD	Input		Memory mode switch input pin	This pin sets the memory expansion mode. If used with the processor mode, set the input high. If used with the single chip mode or memory expansion mode, set the input low.
31~35	IRQ0~ IRQ4	Input	P20, P21(SENS), P22~P24	External interrupt input pins	The valid edge for these external interrupt input pins can be selected with the IRQnICR registers. IRQ1 is an external interrupt pin that is able to determine AC zero crossings. It can also be used as a normal external interrupt. When IRQ0~4 are not used for interrupts, these can be used as normal I/O pins.
2~9	AN0~AN7	Input	PA0~PA7	Analog input pins	Analog input pins for an 8-channel, 10-bit A/D converter. When not used for analog input, these pins can be used as normal I/O pins.
44~51	KEY0~ KEY7	I/O	P40~P47	Key interrupt input pins	Input pins for interrupt based on ORed result of KEY0~7 pin inputs. When not used for KEY input, these pins can be used as normal I/O pins.
32	SENS	Input	IRQ1(P21)	AC zero-cross detection input pin	SENS is an input pin for an AC zero-cross detection circuit. The AC zero-cross circuit outputs a high level when the input is at an intermediate level. It outputs a low level at all other times. SENS is connected to the P21 input circuit and the IRQ1 interrupt circuit. When the AC zero-cross detection circuit is not used, this pin can be used as a normal P21 input. The P21IM flag of the FLOAT1 register sets which input is selected.
39 40 41 42 43	BR BG LDDMA STDMA DKDMA	Input Output Input Input Output	P33~P37	Bus release request input pin Bus use authorization output pin Load cycle input pin Store cycle input pin Memory access complete output pin	Control signals for direct memory access (DMA) of an external memory. BR is the bus release request signal from the external DMA. The BG signal authorizes use of the bus. LDDMA and STDMA are load and store request signals from the external DMA. The DKDMA signal indicates that memory access for the external DMA transfer is complete.
52 53 54 24 55~72 73~80	WE RE CS DK A0~A17 D0~D7	Output Output Output Input Output I/O	P50 P51 P52 P6(BUZZER) P60~P67 P70~P77 P53~P54 P80~P87 (LED0~LED7)	Write enable pin Read enable pin Chip select pin Data acknowledge pin Address pins Data pins	Memory control signals for an expanded memory space external to the MN101CXX. WE is a strobe signal that is output for writing to external memory. RE is a strobe signal that is output for reading from external memory. CS is an chip select signal that is output when external memory is accessed. DK indicates that the external memory access is complete. A0~A17 are address signals output to external memory. D0~D7 are data signals that input data to and output data from external memory.

1-4 Overview of Functions

1-4-1 Block Diagram

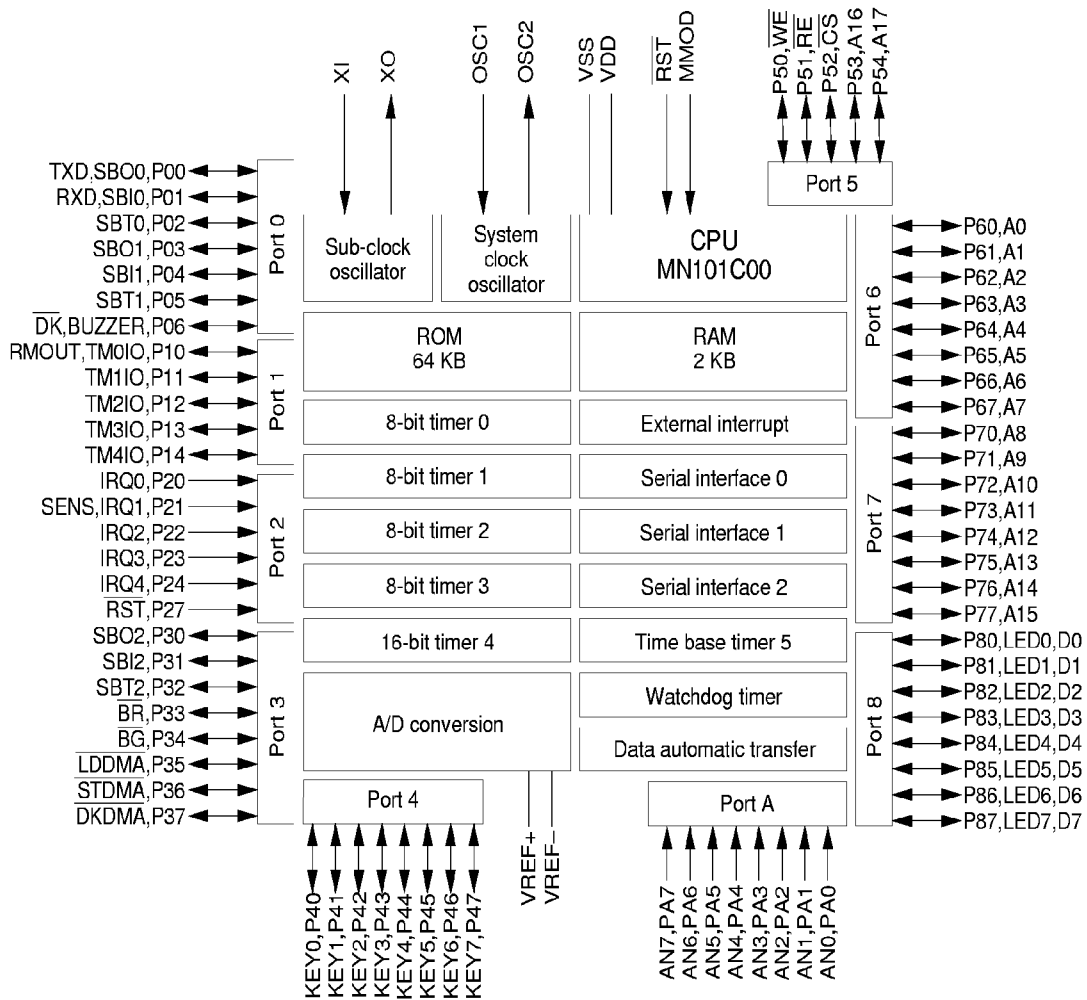

Figure 1-4-1 Block Diagram of Functions

1-5 Electrical Characteristics



This LSI manual describes standard specifications. Before using the LSI, please obtain product specifications from the sales office.

Contents	Model	MN101C01D
Classification	CMOS integrated circuit	
Use	General purpose	
Function	CMOS, 8-bit, single-chip microcomputer	

1-5-1 Absolute Maximum Ratings

Parameter		Symbol	Rating	Unit	
1	Supply voltage	V_{DD}	-0.3~+7.0	V	
2	Input clamp current (SENS)	IC	-400~400	μ A	
3	Input pin voltage	V_I	-0.3~ $V_{DD}+0.3$	V	
4	Output pin voltage	V_O	-0.3~ $V_{DD}+0.3$	V	
5	I/O pin voltage	V_{IO1}	-0.3~ $V_{DD}+0.3$	V	
6	Peak output current	P8	I_{OL1} (peak)	30	mA
7		Except P8	I_{OL2} (peak)	20	
8		All pins	I_{OH} (peak)	-10	
9		P8	I_{OL1} (avg)	20	
10		Other than P8	I_{OL2} (avg)	15	
11		All pins	I_{OH} (avg)	-5	
12	Average output current ^{*1}				
12	Tolerable loss	PT	400	mW	
13	Ambient operating temperature	T_{opr}	-40~85	°C	
14	Storage temperature	T_{stg}	-55~+125	°C	

Note: ^{*1} Applicable even for an interval of 100ms.

1-5-2 Operating Conditions

$$T_a = -40 \sim +85^\circ\text{C} \quad V_{DD} = 2.0 \sim 5.5\text{V} \quad V_{SS} = 0\text{V}$$

Parameter	Symbol	Conditions	Rating			Unit
			MIN	TYP	MAX	
Supply voltage						
1	Supply voltage during operation	V_{DD1}	$f_{osc} \leq 20.0\text{MHz}$	4.5	5.5	V
2		V_{DD2}	$f_{osc} \leq 8.39\text{MHz}$	2.7	5.5	
3		V_{DD3}	$f_{osc} \leq 2.00\text{MHz}$	2.0	5.5	
4		V_{DD4}	$f_x = 32.768\text{kHz}$	2.0	5.5	
5	Voltage to maintain RAM data	V_{DD5}	During STOP mode	1.8	5.5	
Operating speed *1						
6	Instruction execution time	t_{c1}	$V_{DD} = 4.5 \sim 5.5\text{V}$	0.100		μs
7		t_{c2}	$V_{DD} = 2.7 \sim 5.5\text{V}$	0.238		
8		t_{c3}	$V_{DD} = 2.0 \sim 5.5\text{V}$	1.00		
9		t_{c4}	$V_{DD} = 2.0 \sim 5.5\text{V}$		125	
Crystal oscillator 1 Fig. 1-5-1						
10	Crystal frequency	$f_{xtal 1}$	$V_{DD} = 4.5 \sim 5.5\text{V}$	1.0	20.0	MHz
11	External capacitors	C_{11}			20	pF
12		C_{12}			20	
13	Internal feedback resistor	RF10			100	k Ω
Crystal oscillator 2 Fig. 1-5-2						
14	Crystal frequency	$f_{xtal 2}$			32.768	kHz
15	External capacitors	C_{21}			20	pF
16		C_{22}			20	
17	Internal feedback resistor	RF20			1.5	M Ω

Note: *1 t_{c1}, t_{c2}, t_{c3} : where OSC1 is the CPU clock
 t_{c4} : where XI is the CPU clock

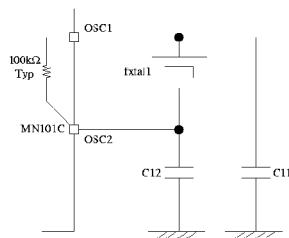

The instruction cycle is twice the clock cycle.
 The feedback resistor is built-in.

Figure 1-5-1 Crystal Oscillator 1

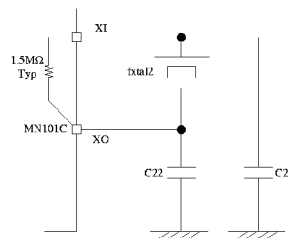

The instruction cycle is four times the clock cycle.
 The feedback resistor is built-in.

Figure 1-5-2 Crystal Oscillator 2

Parameter	Symbol	Conditions	Rating			Unit
			MIN	TYP	MAX	
External clock input 1 OSC1 (OSC2 is unconnected)						
18	Clock frequency	$f_{osc\ 1}$	1.0		20.0	MHz
19	High level pulse width*	$t_{wh\ 1}$	20.0		30.0	ns
20	Low level pulse width*	$t_{wl\ 1}$				
21	Rise time	$t_{wr\ 1}$			5.0	ns
22	Fall time	$t_{wf\ 1}$				
External clock input 2 XI (XO is unconnected)						
23	Clock frequency	$f_{osc\ 2}$	32.768		100	kHz
24	High level pulse width*	$t_{wh\ 2}$	3.5			μ s
25	Low level pulse width*	$t_{wl\ 2}$				
26	Rise time	$t_{wr\ 2}$			20	ns
27	Fall time	$t_{wf\ 2}$				

*1 Set the clock duty ratio to 45~55%.

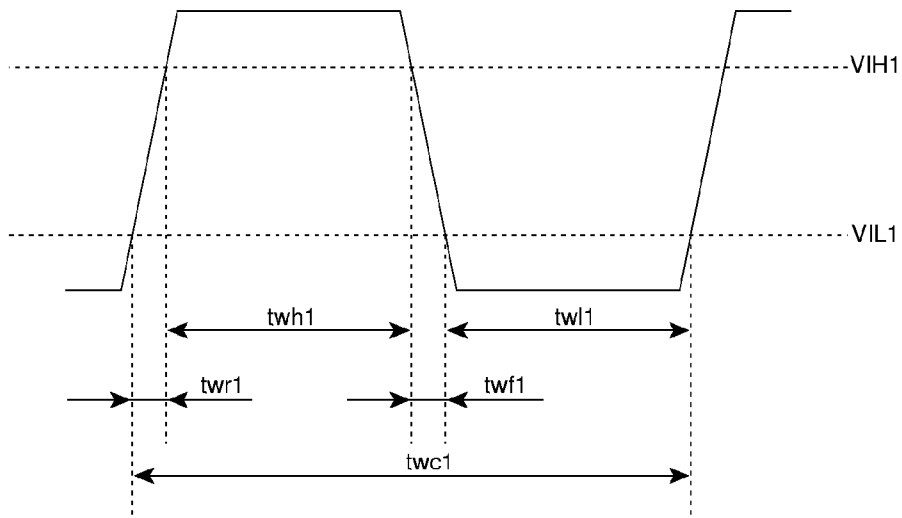

Figure 1-5-3 OSC1 Timing Chart

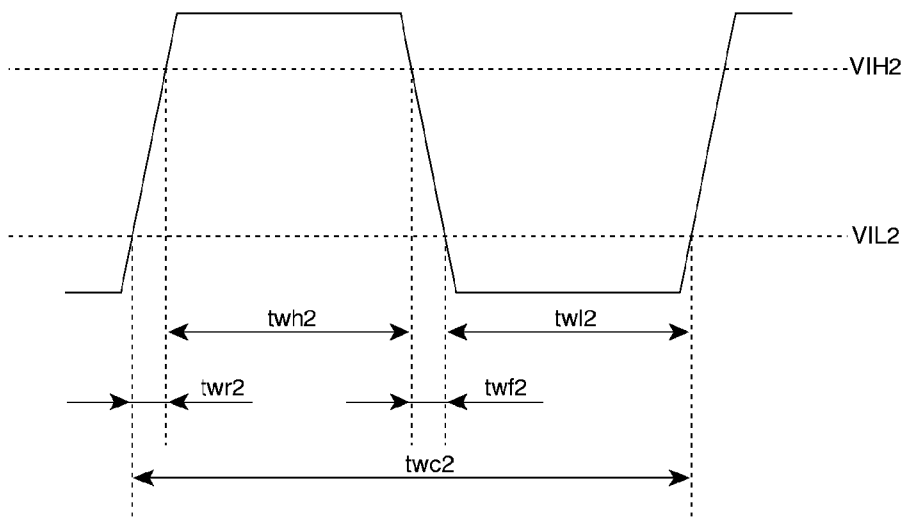

Figure 1-5-4 XI Timing Chart

1-5-3 DC Characteristics

$$T_a = -40 \sim +85^\circ\text{C} \quad V_{DD} = 2.0 \sim 5.5\text{V} \quad V_{SS} = 0\text{V}$$

Parameter	Symbol	Conditions	Rating			Unit	
			MIN	TYP	MAX		
Supply current (no load at output)*1							
1	Supply current during operation	I_{DD1}	fosc=20.0MHz, $V_{DD}=5\text{V}$		25	60	mA
2		I_{DD2}	fosc=8.39MHz, $V_{DD}=5\text{V}$		10	25	
3		I_{DD3}	fx =32.768kHz, $V_{DD}=3\text{V}$		t. b. f	t. b. f (120 μA)	μA
4	Supply current during HALT mode	I_{DD4}	fx =32.768kHz, $V_{DD}=3\text{V}$		4	8	
5	Supply current during STOP mode	I_{DD5}	$V_{DD}=5\text{V}$		0	2	

Notes: *1 Measured under conditions of $T_a=25^\circ\text{C}$ and no load.

The supply current during operation, I_{DD1} (I_{DD2}), is measured under the following conditions: After all I/O pins are set to input mode and the oscillation is set to <NORMAL mode>, the MMOD pin is fixed at V_{SS} , the input pins are fixed at V_{DD} , and a 20MHz (8.39MHz) square wave of amplitude V_{DD} , V_{SS} is input to the OSC1 pin.

The supply current during operation, I_{DD3} , is measured under the following conditions: After all I/O pins are set to input mode and the oscillation is set to <SLOW mode>, the MMOD pin is fixed at V_{SS} , the input pins are fixed at V_{DD} , and a 32.768kHz square wave of amplitude V_{DD} , V_{SS} is input to the XI pin.

The supply current during HALT mode, I_{DD4} , is measured under the following conditions: After all I/O pins are set to input mode and the oscillation is set to <HALT mode>, the MMOD pin is fixed at V_{SS} , the input pins are fixed at V_{DD} , and an 32.768kHz square wave of amplitude V_{DD} , V_{SS} is input to the OSC1 pin.

The supply current during STOP mode is measured under the following conditions: After the oscillation mode is set to <STOP mode>, the MMOD pin is fixed at V_{SS} , the input pins are fixed at V_{DD} , and the OSC1 and XI pins are unconnected.

$$T_a = -40 \sim +85^\circ\text{C} \quad V_{DD} = 2.0 \sim 5.5\text{V} \quad V_{SS} = 0\text{V}$$

Parameter	Symbol	Conditions	Rating			Unit	
			MIN	TYP	MAX		
Input pin 1 MMOD							
6	Input high voltage 1	V_{IH1}		$0.8V_{DD}$	V_{DD}	V	
7	Input high voltage 2	V_{IH2}	$V_{DD} = 4.5 \sim 5.5\text{V}$	$0.7V_{DD}$	V_{DD}	V	
8	Input low voltage 1	V_{IL1}		0	$0.2V_{DD}$	V	
9	Input low voltage 2	V_{IL2}	$V_{DD} = 4.5 \sim 5.5\text{V}$	0	$0.3V_{DD}$	V	
10	Input leakage current	I_{LK1}	$V_{IN} = 0 \sim V_{DD}$		± 10	μA	
Input pin 2 P20, P22~P24 (Schmitt trigger input)							
11	Input high voltage	V_{IH3}		$0.8V_{DD}$	V_{DD}	V	
12	Input low voltage	V_{IL3}	$V_{DD} = 5\text{V}$, $V_{IN} = 1.5\text{V}$ Pull-up resistor ON	0	$0.2V_{DD}$	V	
13	Input leakage current	I_{LK3}	$V_{IN} = 0 \sim V_{DD}$		± 10	μA	
14	Input high current	I_{IH3}		-30	-100	-300	μA
Input pin 3—1 P21 (Schmitt trigger input)							
15	Input high voltage	V_{IH4}		$0.8V_{DD}$	V_{DD}	V	
16	Input low voltage	V_{IL4}		0	$0.2V_{DD}$	V	
17	Input leakage current	I_{LK4}	$V_{IN} = 0 \sim V_{DD}$		± 10	μA	
18	Input high current	I_{IH4}	$V_{DD} = 5\text{V}$, $V_{IN} = 1.5\text{V}$ Pull-up resistor ON	-30	-100	-300	μA
Input pin 3—2 P21 (when used as SENS)							
19	Input high voltage 1	V_{DHH}		4.5	V_{DD}	V	
20	Input low voltage 1	V_{DLH}	Fig. 1-5-5	V_{SS}	3.5		
21	Input high voltage 2	V_{DHL}		1.5	V_{DD}	V	
22	Input low voltage 2	V_{DLL}		V_{SS}	0.5		
23	Input leakage current	I_{LK10}		$V_{IN} = 0\text{V} \sim V_{DD}$		± 10	μA
24	Input clamp current	I_{C10}	$V_{IN} > V_{DD}$, $V_{IN} < 0\text{V}$		± 400		

SENS pin

25	Rise time	tr _s	Fig. 1-5-5	30		μs
26	Fall time	tf _s		30		

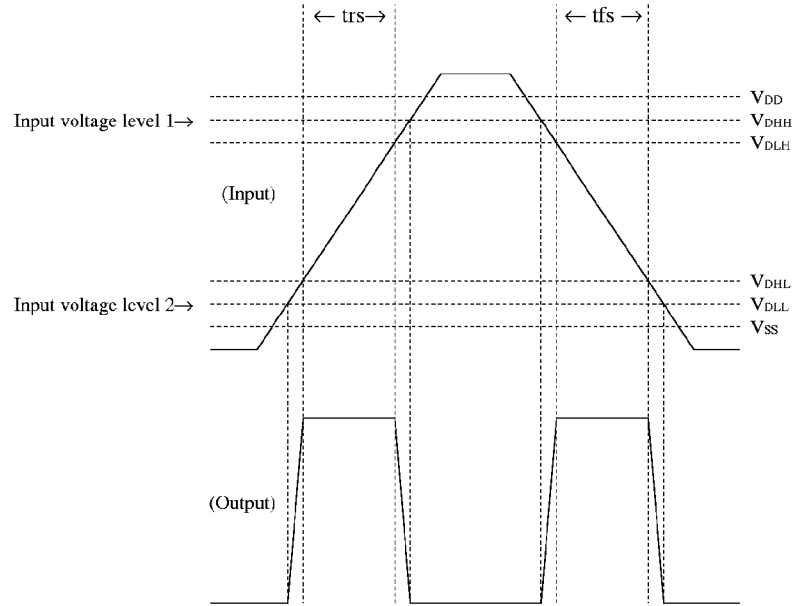

Figure 1-5-5 Operation of AC Zero-Cross Detection Circuit

$T_a = -40 \sim +85^\circ\text{C}$ $V_{DD} = 2.0 \sim 5.5\text{V}$ $V_{SS} = 0\text{V}$

Parameter	Symbol	Conditions	Rating			Unit	
			MIN	TYP	MAX		
Input pin 4 PA0~PA7							
27	Input high voltage 1	V_{IH5}	$0.8V_{DD}$		V_{DD}	V	
28	Input high voltage 2	V_{IH6}	$V_{DD} = 4.5 \sim 5.5\text{V}$	$0.7V_{DD}$	V_{DD}	V	
29	Input low voltage 1	V_{IL5}	0		$0.2V_{DD}$	V	
30	Input low voltage 2	V_{IL6}	$V_{DD} = 4.5 \sim 5.5\text{V}$	0	$0.3V_{DD}$	V	
31	Input leakage current	I_{LK5}	$V_{IN} = 0 \sim V_{DD}$		± 2	μA	
32	Input high current	I_{IH5}	$V_{DD} = 5\text{V}$, $V_{IN} = 1.5\text{V}$ Full up resistor ON	30	100	300	μA
33	Input low current	I_{IL5}	$V_{DD} = 5\text{V}$, $V_{IN} = 3.5\text{V}$ Pull-down resistor ON	30	100	300	μA

$$T_a = -40 \sim +85^\circ\text{C} \quad V_{DD} = 2.0 \sim 5.5\text{V} \quad V_{SS} = 0\text{V}$$

Parameter	Symbol	Conditions	Rating			Unit	
			MIN	TYP	MAX		
I/O pin 5 P27 (RST)							
34	Input high voltage	V_{IH7}	$0.9V_{DD}$		V_{DD}	V	
35	Input low voltage	V_{IL7}	0		$0.2V_{DD}$	V	
36	Input leakage current	I_{LK7}	$V_{IN} = 0 \sim V_{DD}$		± 10	μA	
37	Input high current	I_{IH7}	$V_{DD} = 5\text{V}, V_{IN} = 1.5\text{V}$ Internal pull-up resistor	-30	-100	-300	μA
38	Output low voltage	V_{OL7}	$V_{DD} = 5\text{V}, I_{OL} = 1.0\text{mA}$		0.5	V	
I/O pin 6 P00~P06, P10~P14, P30~P37, P40~P47 (Schmitt trigger input)							
39	Input high voltage	V_{IH8}	$0.8V_{DD}$		V_{DD}	V	
40	Input low voltage	V_{IL8}	0		$0.2V_{DD}$	V	
41	Input leakage current	I_{LK8}	$V_{IN} = 0 \sim V_{DD}$		± 10	μA	
42	Input high current	I_{IH8}	$V_{DD} = 5\text{V}, V_{IN} = 1.5\text{V}$ Pull-up resistor ON	-30	-100	-300	μA
43	Output high voltage	V_{OH8}	$V_{DD} = 5\text{V}, I_{OH} = 0.5\text{mA}$	4.5		V	
44	Output low voltage	V_{OL8}	$V_{DD} = 5\text{V}, I_{OL} = 1.0\text{mA}$		0.5	V	
I/O pin 7 P50~P54, P60~P67							
45	Input high voltage 1	V_{IH9}	$0.8V_{DD}$		V_{DD}	V	
46	Input high voltage 2	V_{IH10}	$V_{DD} = 4.5 \sim 5.5\text{V}$	$0.7V_{DD}$		V_{DD}	V
47	Input low voltage 1	V_{IL9}		0		$0.2V_{DD}$	V
48	Input low voltage 2	V_{IL10}	$V_{DD} = 4.5 \sim 5.5\text{V}$	0		$0.3V_{DD}$	V
49	Input leakage current	I_{LK9}	$V_{IN} = 0 \sim V_{DD}$		± 10	μA	
50	Input high current	I_{IH9}	$V_{DD} = 5\text{V}, V_{IN} = 1.5\text{V}$ Pull-up resistor ON	-30	-100	-300	μA
51	Output high voltage	V_{OH9}	$V_{DD} = 5\text{V}, I_{OH} = -0.5\text{mA}$	4.5		V	
52	Output low voltage	V_{OL9}	$V_{DD} = 5\text{V}, I_{OL} = 1.0\text{mA}$		0.5	V	
I/O pin 8 P70~P77							
53	Input high voltage 1	V_{IH11}	$0.8V_{DD}$		V_{DD}	V	
54	Input high voltage 2	V_{IH12}	$V_{DD} = 4.5 \sim 5.5\text{V}$	$0.7V_{DD}$		V_{DD}	V
55	Input low voltage 1	V_{IL11}		0		$0.2V_{DD}$	V
56	Input low voltage 2	V_{IL12}	$V_{DD} = 4.5 \sim 5.5\text{V}$	0		$0.3V_{DD}$	V
57	Input leakage current	I_{LK8}	$V_{IN} = 0 \sim V_{DD}$		± 10	μA	
58	Input high current	I_{IH8}	$V_{DD} = 5\text{V}, V_{IN} = 1.5\text{V}$ Pull-up resistor ON	-30	-100	-300	μA
59	Input low current	I_{IL8}	$V_{DD} = 5\text{V}, V_{IN} = 3.5\text{V}$ Pull-down resistor ON	30	100	300	μA
60	Output high voltage	V_{OH8}	$V_{DD} = 5\text{V}, I_{OH} = -0.5\text{mA}$	4.5		V	
61	Output low voltage	V_{OL8}	$V_{DD} = 5\text{V}, I_{OL} = 1.0\text{mA}$		0.5	V	

$T_a = -40 \sim +85^\circ\text{C}$ $V_{DD} = 2.0 \sim 5.5\text{V}$ $V_{SS} = 0\text{V}$

Parameter	Symbol	Conditions	Rating			Unit	
			MIN	TYP	MAX		
I/O pin 9 P80~P87							
62	Input high voltage 1	V_{IH13}	$0.8V_{DD}$		V_{DD}	V	
63	Input high voltage 2	V_{IH14}	$V_{DD} = 4.5 \sim 5.5\text{V}$	$0.7V_{DD}$	V_{DD}	V	
64	Input low voltage 1	V_{IL13}	0		$0.2V_{DD}$	V	
65	Input low voltage 2	V_{IL14}	$V_{DD} = 4.5 \sim 5.5\text{V}$	0	$0.3V_{DD}$	V	
66	Input leakage current	I_{LK13}	$V_{IN} = 0 \sim V_{DD}$		± 10	μA	
67	Input high current	I_{IH13}	$V_{DD} = 5\text{V}$, $V_{IN} = 1.5\text{V}$ Pull up resistor ON	-30	-100	-300	μA
68	Output high voltage	V_{OH13}	$V_{DD} = 5\text{V}$, $I_{OH} = -0.5\text{mA}$	4.5			V
69	Output low voltage	V_{OL13}	$V_{DD} = 5\text{V}$, $I_{OL} = 15\text{mA}$		1.0		V

1-5-4 A/D Converter Characteristics

 $T_a = -40 \sim +85^\circ\text{C}$ $V_{DD} = 2.0 \sim 5.5\text{V}$ $V_{SS} = 0\text{V}$

Parameter	Symbol	Conditions	Rating			Unit
			MIN	TYP	MAX	
1	Resolution				10	Bits
2	Nonlinear error 1	$V_{DD} = 5.0\text{V}$, $V_{SS} = 0\text{V}$ $V_{REF+} = 5.0\text{V}$, $V_{REF-} = 0\text{V}$ $T_{AD} = 800\text{ns}$			± 3	LSB
3	Differential linear error 1				± 3	LSB
4	Nonlinear error 2	$V_{DD} = 5.0\text{V}$, $V_{SS} = 0\text{V}$ $V_{REF+} = 5.0\text{V}$, $V_{REF-} = 0\text{V}$ $f_{OSC} = 32.768\text{kHz}$			± 5	LSB
5	Differential linear error 2				± 5	LSB
6	Zero traction voltage	$V_{DD} = 5.0\text{V}$, $V_{SS} = 0\text{V}$ $V_{REF+} = 5.0\text{V}$, $V_{REF-} = 0\text{V}$ $T_{AD} = 800\text{ns}$		30	100	mV
7	Full-scale transition voltage		4900	4970		mV
8	A/D conversion time	$T_{AD} = 800\text{ns}$	9.6			μs
9		$f_{OSC} = 32.768\text{kHz}$			183	μs
10		$f_{OSC} = 8\text{MHz}$	1.0		36	μs
11	Sampling time	$f_{OSC} = 32.768\text{kHz}$		30.5		μs
12	Reference voltage	V_{REF+}	V_{REF-}		V_{DD}	V
13		V_{REF-}	V_{SS}		V_{REF+}	
14	Analog input voltage		V_{REF-}		V_{REF+}	
15	Analog input leakage current	When $V_{DAIN} = 0 \sim 5\text{V}$ is off			± 2	μA
16	Reference voltage pin input leakage current	When V_{REF-} is off $V_{REF-} \leq V_{REF+} \leq V_{DD}$			± 10	μA
17	Value of ladder resistor	R_{ladd} $V_{DD} = 5.0\text{V}$	20	50	80	k Ω

1-5-5 Bus Timing (0 wait states) during Memory Expansion

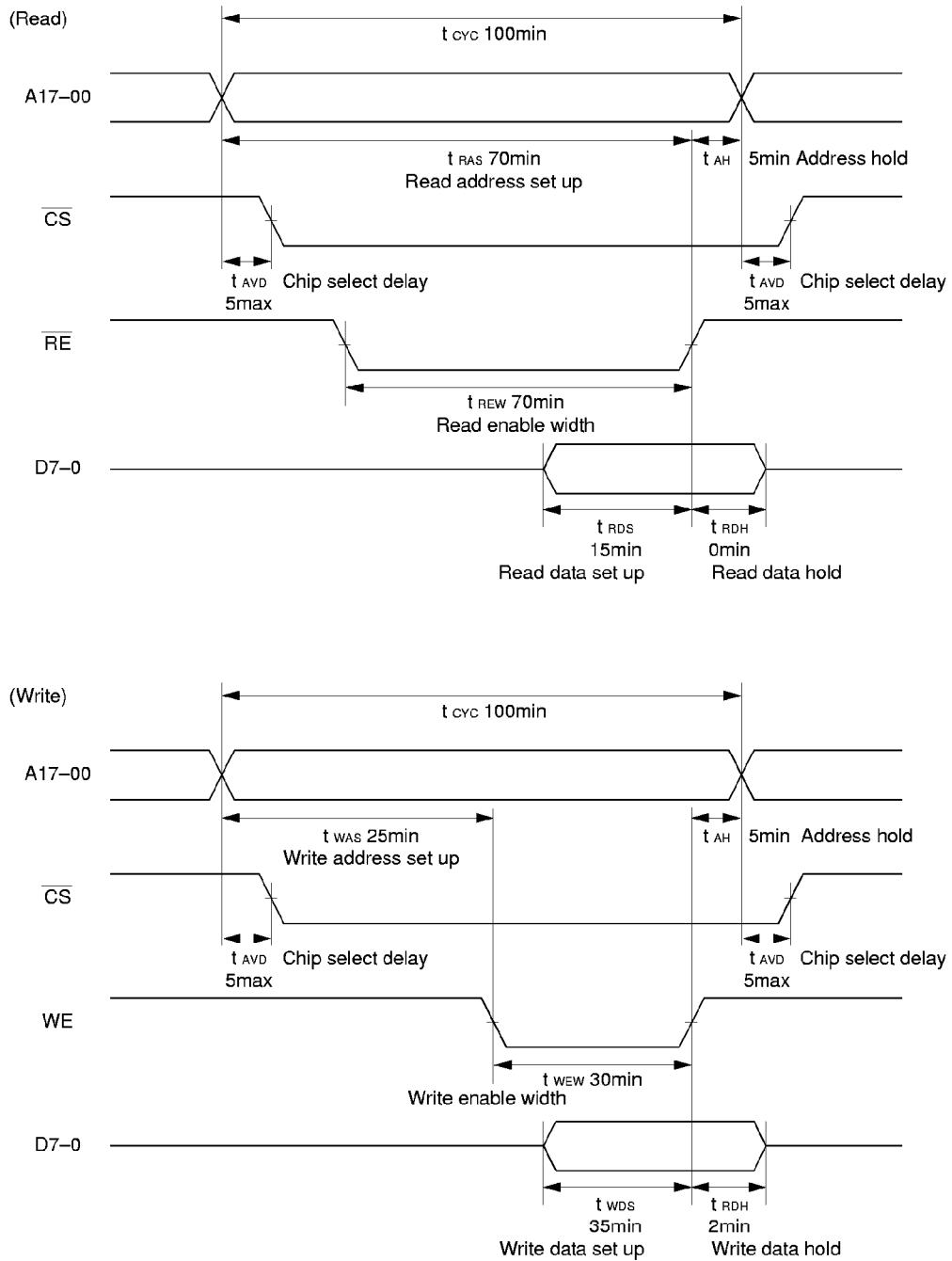

Figure 1-5-6 Bus Timing for Memory Expansion Mode with 0 Wait States

1-6 Mask Option Form

Date:

SE No. _____

Model Name	MN101C
------------	--------

Customer		Approval	
----------	--	----------	--

1. Oscillation mode

Type A	Type B

Note: Type A: Operation begins from the reset cycle in the NORMAL mode.
 Type B: Operation begins from the reset cycle in the SLOW mode.

2. Watchdog timer period setting

Detection Period	Selection
$fs/2^{16}$	
$fs/2^{18}$	
$fs/2^{20}$	



Contents of mask option are subject to change.

When placing an order for masks, please request the most recent option list from the sales office.

1-7 External Dimensions

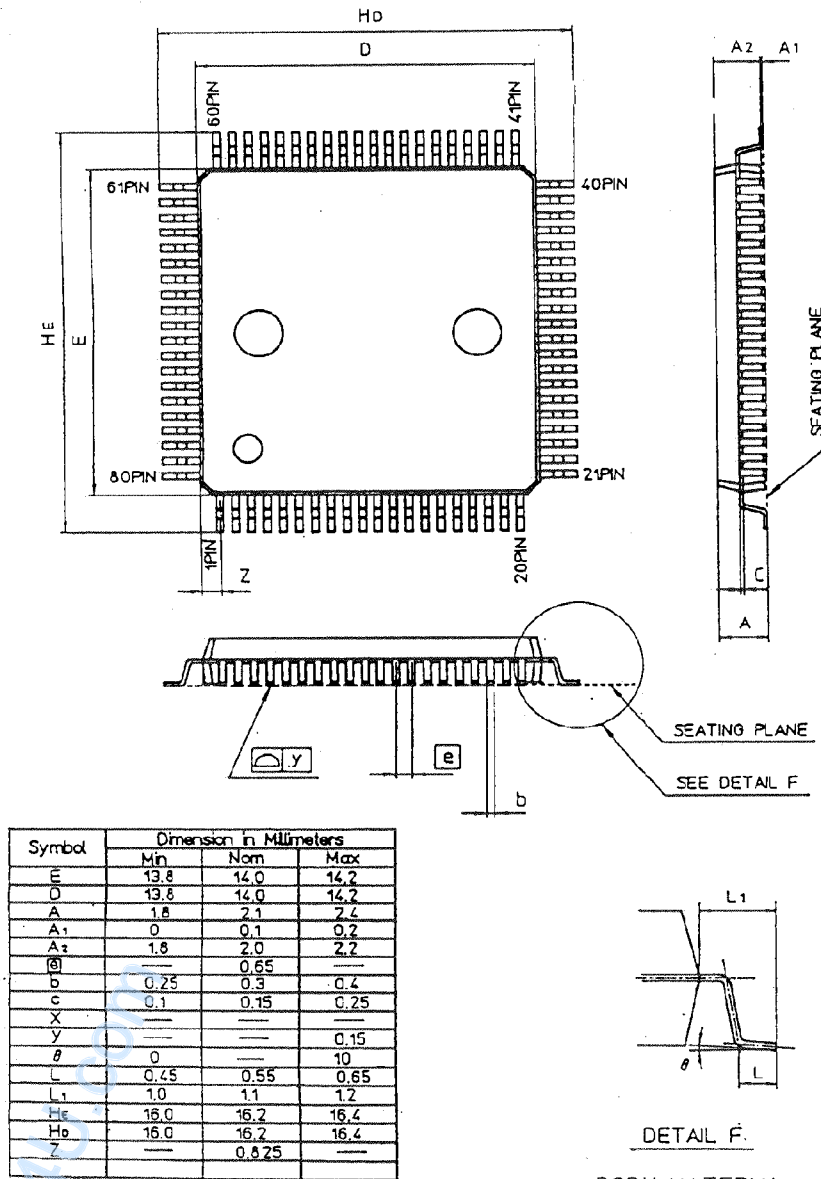

Figure 1-7-1 80-Pin QFS



The external dimensions of the package are subject to change. Before using this product, please obtain product specifications from the sales office.

Chapter 2 Basic CPU
Functions



2-1 Overview

Basic CPU functions are in conformance with the MN101C00 series manual (architecture manual). This chapter describes specifications unique to the MN101C01D.

2-2 Address Space

2-2-1 Memory Configuration

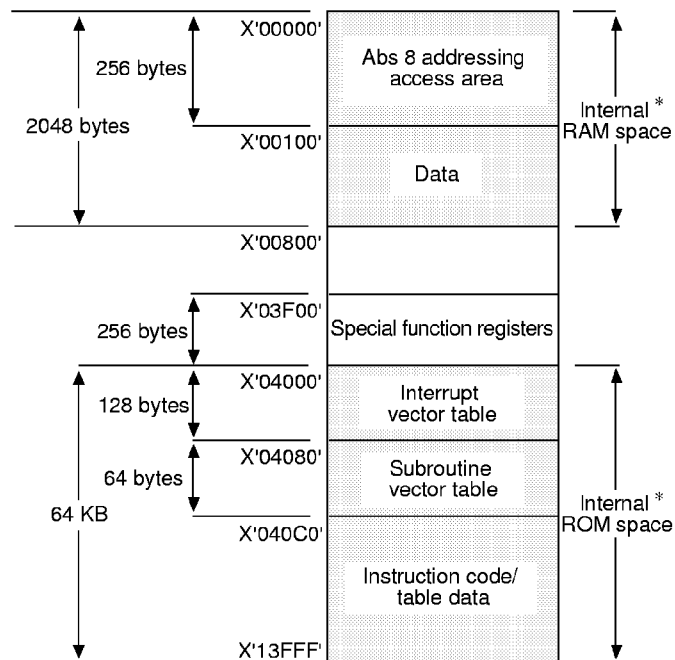

Figure 2-2-1 Memory Map

* Differs depending upon the model.

MN101C01A	Internal RAM	X'00000'~X'005FF'	1536 bytes
	Internal ROM	X'04000'~X'0BFFF'	32 KB
MN101C01C	Internal RAM	X'00000'~X'007FF'	2048 bytes
	Internal ROM	X'04000'~X'0FFFF'	48 KB
MN101CP01D	Internal RAM	X'00000'~X'007FF'	2048 bytes
	Internal ROM	X'04000'~X'13FFF'	64 KB

2-2-2 Special Function Registers

Table 2-2-1 Register Map

	0	1	2	3	4	5	6	7	8	9	A	B	C	D	E	F	
03F0X	CPUM	MEMCTR	WDCCTR	DLYCTR											EX ADV		CPU mode, memory control
03F1X	P0OUT	P1OUT	P2OUT	P3OUT	P4OUT	P5OUT	P6OUT	P7OUT	P8OUT							SYSDV	Port output
03F2X	P0IN	P1IN	P2IN	P3IN	P4IN	P5IN	P6IN	P7IN	P8IN		PAIN						Port input
03F3X	P0DIR	P1DIR		P3DIR	P4DIR	P5DIR	P6DIR	P7DIR	P8DIR	P1CMD	PAIMD		P4IMD				I/O mode control
03F4X	P0PLU	P1PLU	P2PLU	P3PLU	P4PLU	P5PLU	P6PLU	P7PLU	P8PLU		PAPLUD	FLOAT1	FLOAT2				Resistor control
03F5X	SC0MD0	SC0MD1	SC0MD2	SC0MD3	SC0CTR	SC0TRB	SC0RXB	SC1MD0	SC1MD1	SC1TRB	SC2MD0	SC2MD1	SC2CTR	SC2TRB			Serial interface control
03F6X	TM0EC	TM1BC	TM2BC	TM3BC	TM4BC	TM4BC	TM4CH	TM4CL	TM4C1	TM5BC							Timer control
03F7X	TM0CC	TM1CC	TM2CC	TM3CC	TM4CC	TM4CH			TM5CC								
03F8X	TM0MD	TM1MD	TM2MD	TM3MD	TM4MD				TM5MD	RMCTR	NFCCTR						
03F9X	ANCTR0	ANCTR1	ANBUFC	ANBUF1													A/D control
03FAX	ATMD	ATCNT	ATTAPL	ATTAPH	ATIAP												ATC control
03FBX																	Reserved
03FCX																	
03FDX																	
03FEX		NM1CR	IRQ0CR	IRQ1CR	TM0ICR	TM1CR	TM2ICR	TBICR	SC0ICR	ATCICR	ADICR	RQ2ICR	IRC3ICR	IRQ4ICR	TM3ICR	TM4ICR	Interrupt control
03FFX	TM5ICR	SC1ICR	SC2ICR														

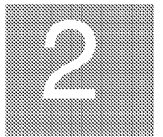

2-3 Bus Interface

2-3-1 Overview

The MN101C01D has a maximum memory space of 256 KB that may be connected to ROM, RAM or external I/O devices. There are two external expansion modes, memory expansion mode and processor mode.

2-3-2 Memory Expansion Mode

This mode uses both internal ROM/RAM and external expanded ROM/RAM.

The memory expansion mode is set by assigning bit 4 (EXMEM) of the memory control register (MEMCTR) to a value of '1', and by setting bits 7~5 of the expansion address control register (EXADV) to enable pins A8~A17.

Memory areas can be externally expanded as follows:

ROM area ... X'20000'~X'3FFFF' 128 KB

RAM area ... X'02F00'~X'03EFF' 4 KB

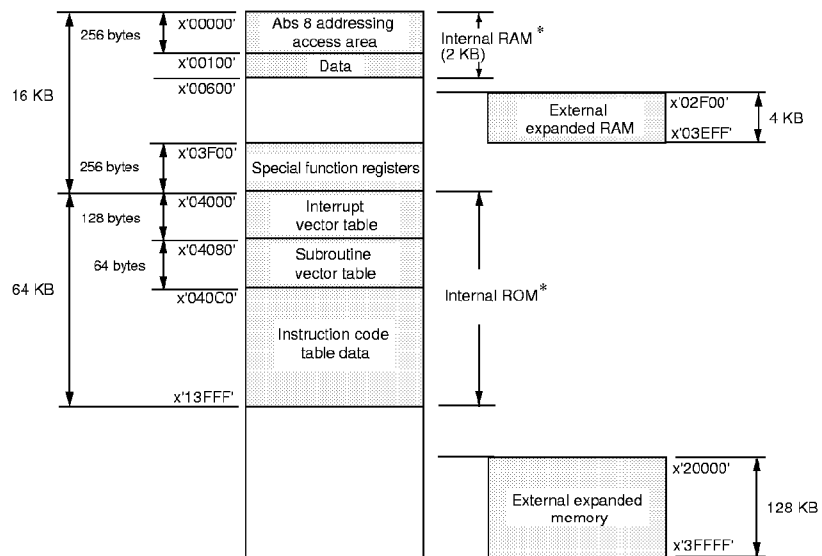

* Differs depending upon the model.

[*☞ 2-2-1 "Memory Configuration"]

MMOD pin = L
EXMEM flag = 1

Figure 2-3-1 Memory Expansion Mode

2-3-3 Processor Mode

This mode uses internal RAM and external expanded ROM/RAM.

The processor mode is set by pulling the MMOD pin to high.

Memory areas can be externally expanded as follows:

ROM area ... X'04000'~X'3FFFF' 240 KB

RAM area ... X'02F00'~X'03EFF' 4 KB

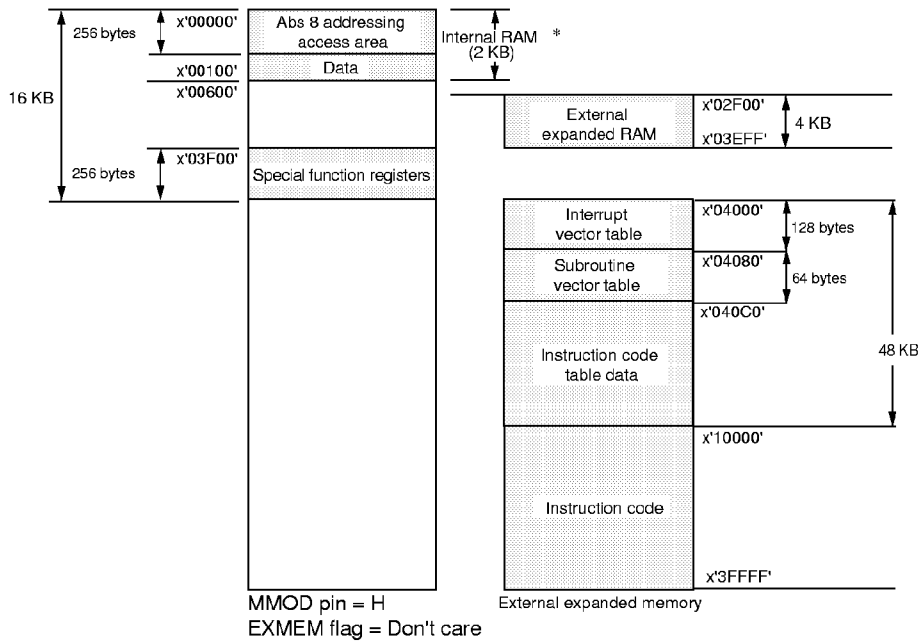

Figure 2-3-2 Processor Mode

*Differs depending upon the model.

MN101C01A	Internal RAM	X'00000'~X'005FF'	1536 bytes
MN101C01C	Internal RAM	X'00000'~X'007FF'	2048 bytes
MN101CP01D	Internal RAM	X'00000'~X'007FF'	2048 bytes

2-3-4 External Memory Connection Example

■ ROM Connection Example (processor mode)

This example shows connection to 512 KB of ROM.

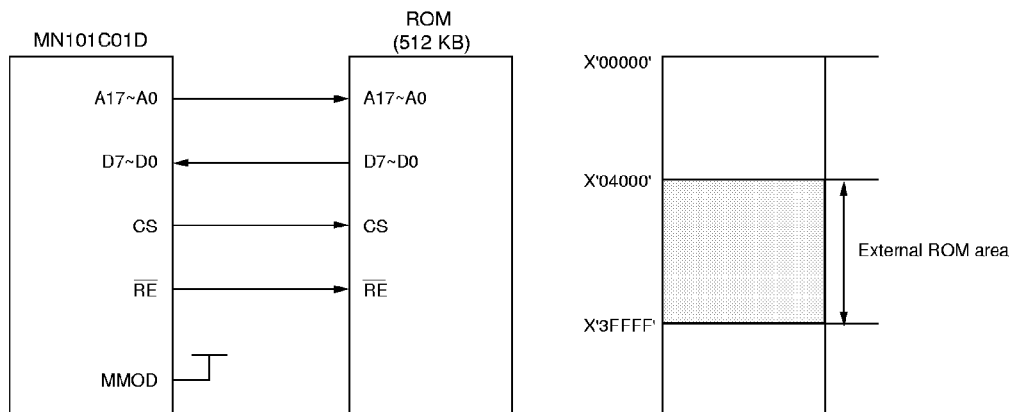

Figure 2-3-3 ROM Connection Example

■ SRAM Connection Example

This example shows connection to 64 KB of SRAM.

The external expansion RAM area is X'002F00'~X'03EFF'.

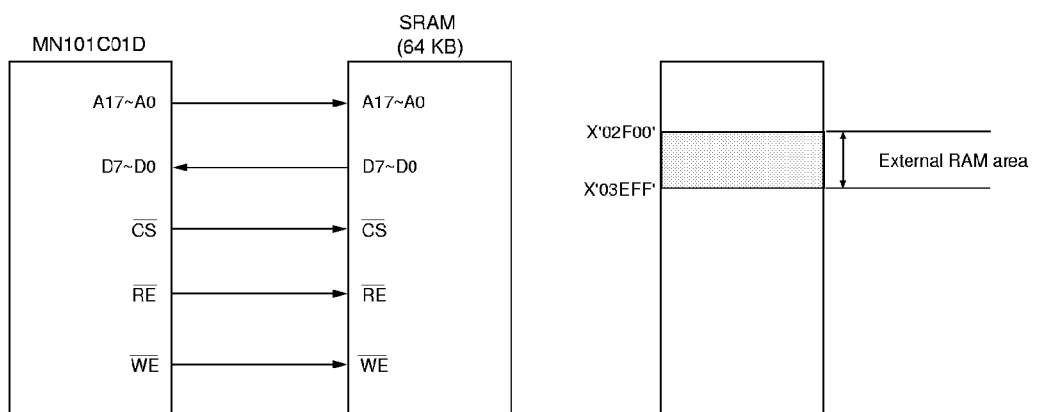

Figure 2-3-4 SRAM Connection Example

■ Access Timing with No Wait Cycles

The \overline{RE} or \overline{WE} timing is determined by OSC2. However, since the delay from OSC2 to \overline{RE} or \overline{WE} varies depending upon the product, use \overline{RE} or \overline{WE} as the reference when synchronizing with other devices. For detailed timing information, refer to the product bus timing specification.

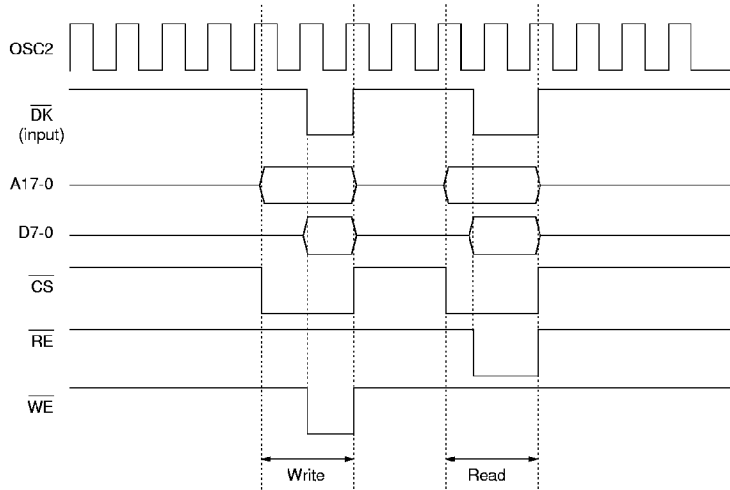

Figure 2-3-5 ROM and RAM Access Timing with No Wait Cycles

■ Access Timing with 1 Wait Cycle

Access timing with 2 and 3 wait cycles follows the same pattern. The latter part of the cycle is extended and the timing is the same.

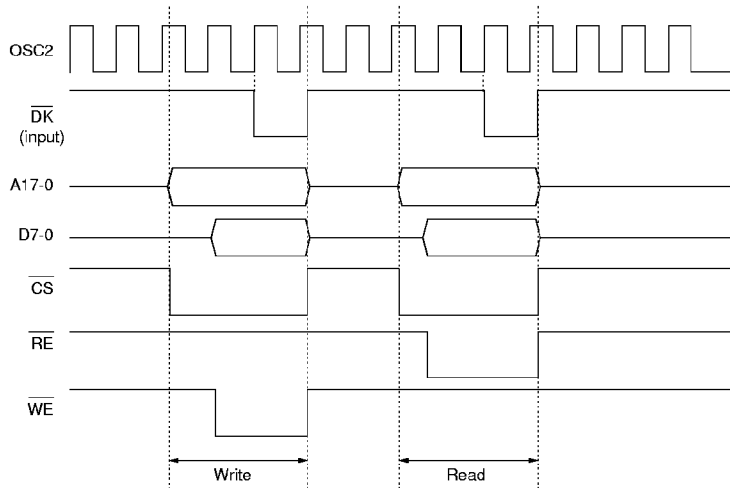

Figure 2-3-6 ROM and RAM Access Timing with 1 Wait Cycle

2-3-5 Control Registers

Two byte-length registers control the bus interface: the memory control register (MEMCTR) and the expansion address control register (EXADV).

(1) Memory control register (MEMCTR)

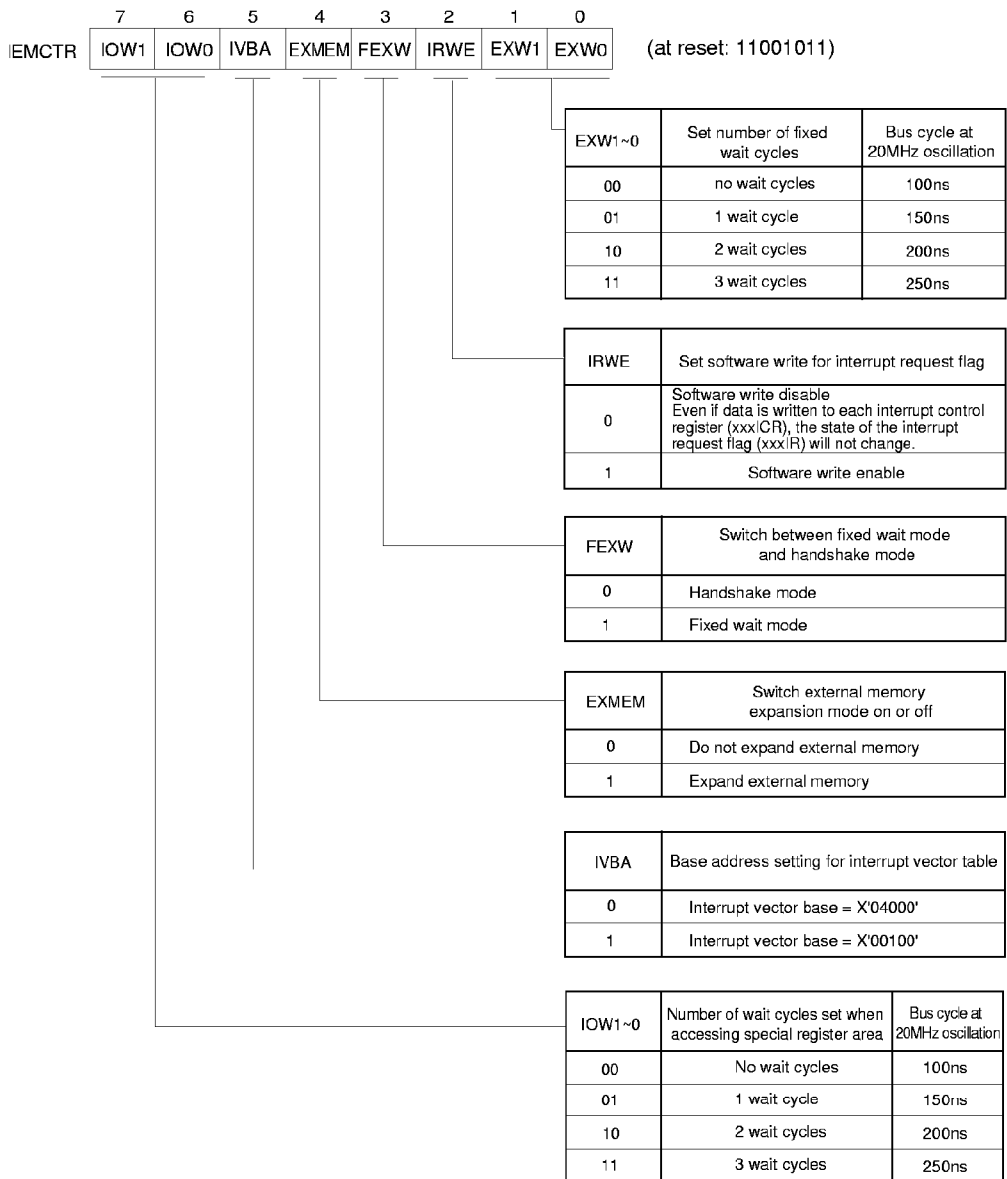

Figure 2-3-7 Memory Control Register (MEMCTR: X'03F01', R/W)

(2) Expansion address control register (EXADV)

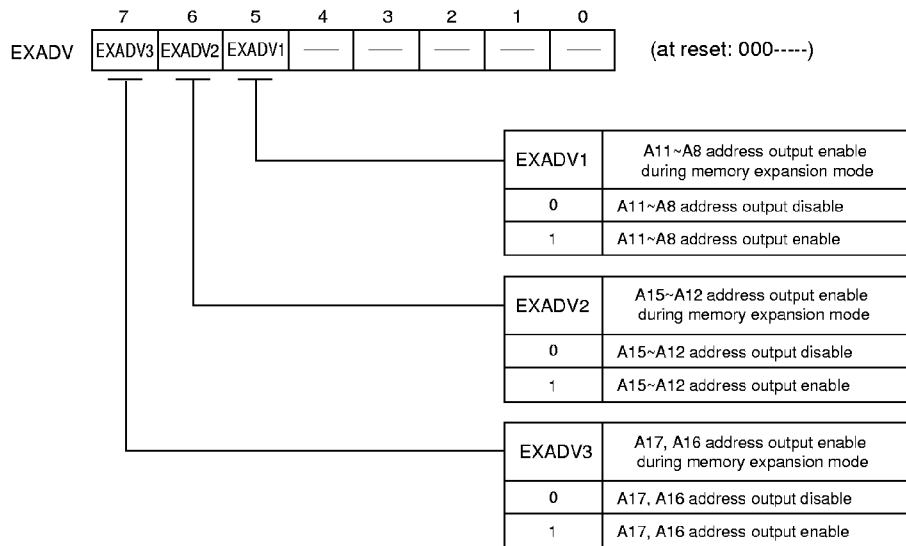

Figure 2-3-8 Expansion Address Control Register (EXADV: X'03F0E', R/W)

2-4 Interrupts

2-4-1 Accepting and Returning from Interrupts

In the MN101C00 series, when an interrupt is accepted, the hardware pushes the program's return address and the PSW, on to the stack, and branches to the beginning address of the interrupt program specified by the interrupt vector table.

■ Operation when Interrupt is Accepted

1. The stack pointer (SP) contents are update. (SP-6 → SP)
2. The handy address register (HA) is pushed on to the stack.
 HA upper byte → (SP+5)
 HA lower byte → (SP+4)
3. The program counter (PC = return address) contents are pushed on to the stack.
 PC (bit 18~bit 17, bit 0) → (SP+3)
 PC (bit 16~bit 9) → (SP+2)
 PC (bit 8~bit 1) → (SP+1)
4. The PSW is pushed on to the stack.
 PSW → (SP)
5. Copy xxxLVn of the accepted interrupt is copied to IM of the PSW.
 Interrupt level → IM
6. Execution branches to vector table.

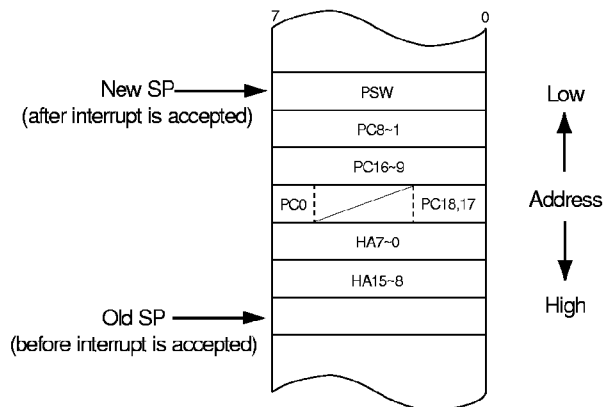

Figure 2-4-1 Stack Status during an Interrupt



Since the contents of data and address registers are not saved, use PUSH instructions in the program to save these values as necessary on the stack.

■ Operation when Returning from Interrupt

After the program POPS the register and other values saved by the interrupt service routine, an RTI instruction is implemented to return to the program that was being executed when the interrupt was received.

The processing sequence for the return from interrupt instruction, RTI, is listed below.

1. The processor status word (PSW) is pulled from the stack. (SP)
2. The program counter (PC = return address) is pulled from the stack. (SP+1~3)
3. The handy address register (HA) is pulled from the stack. (SP+4, 5)
4. The SP is pulled. (SP+6 → SP)
5. Execution branches to the address indicated by the PC.

2-4-2 Interrupt Sources and Vector Addresses

In addition to reset, there are 20 interrupt vectors that indicate the starting addresses of interrupt programs. These vectors are located in the 80-byte ROM address area X'04004'~X'04053'.

Table 2-4-1 Interrupt Control Registers

Vector Number	Interrupt Source	Control Register (address)	Vector Address
0	Reset	—————	X'04000'
1	Non-maskable interrupt (NMI)	NMICR (X'03FE1')	X'04004'
2	External interrupt 0 (IRQ0)	IRQ0ICR (X'03FE2')	X'04008'
3	External interrupt 1 (IRQ1)	IRQ1ICR (X'03FE3')	X'0400C'
4	Timer 0 compare-match (TM0IRQ)	TM0ICR (X'03FE4')	X'04010'
5	Timer 1 compare-match (TM1IRQ)	TM1ICR (X'03FE5')	X'04014'
6	Timer 2 compare-match (TM2IRQ)	TM2ICR (X'03FE6')	X'04018'
7	Time base period (TBIRQ)	TBICR (X'03FE7')	X'0401C'
8	SC0 transfer complete (SC0IRQ)	SC0ICR (X'03FE8')	X'04020'
9	ATC transfer complete (ATCIRQ)	ATCICR (X'03FE9')	X'04024'
10	A/D conversion complete (ADIRQ)	ADICR (X'03FEA')	X'04028'
11	External interrupt 2 (IRQ2)	IRQ2ICR (X'03FEB')	X'0402C'
12	External interrupt 3 (IRQ3)	IRQ3ICR (X'03FEC')	X'04030'
13	External interrupt 4 (IRQ4)	IRQ4ICR (X'03FED')	X'04034'
14	Timer 3 compare-match (TM3IRQ)	TM3ICR (X'03FEE')	X'04038'
15	Timer 4 compare-match (TM4IRQ)	TM4ICR (X'03FEF')	X'0403C'
16	Timer 5 compare-match (TM5IRQ)	TM5ICR (X'03FF0')	X'04040'
17	SC1 transfer complete (SC1IRQ)	SC1ICR (X'03FF1')	X'04044'
18	SC2 transfer complete (SC2IRQ)	SC2ICR (X'03FF2')	X'04048'
19	Reserved	(X'03FF3')	X'0404C'
20	Reserved	(X'03FF4')	X'04050'



Set the vector addresses for reserved and unused interrupts to an address containing an RTI instruction.

2-4-3 Interrupt Control Registers

Interrupt control registers consist of the following: a non-maskable interrupt control register (NMICR), external interrupt control registers (IRQnICR), and internal interrupt control registers (TMnICR, TBICR, SCnICR, ATCICR, ADICR).

■ Non-maskable Interrupt Control Register (NMICR)

Non-maskable interrupt factors are stored in the non-maskable interrupt control register (NMICR), and are used when a non-maskable interrupt is generated.

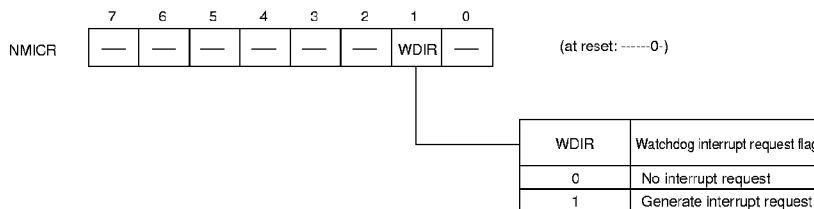

Be sure to use the MIE flag of the PSW register to write to all interrupt control registers.

Figure 2-4-2 Non-maskable Interrupt Control Register (NMICR: X'03FE1', R/W)

■ External Interrupt Control Registers (IRQnICR)

The external interrupt control registers (IRQnICR) control the interrupt level, valid edge, and request/enable.

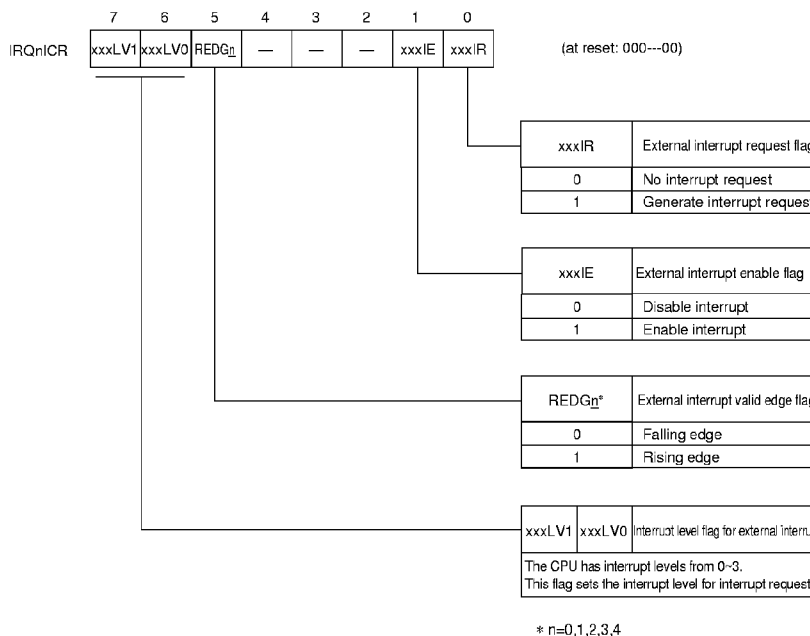

By setting xxxLVn to '11' (level 3), the corresponding interrupt vector will be disabled, regardless of the state of the interrupt enable and interrupt request flags.

Figure 2-4-3 External Interrupt Control Register (IRQnICR: X'03FE2'~X'03FE3', X'03FEB'~X'03FED', R/W)

■ Internal Interrupt Control Registers (TMnICR, TBICR, SCnICR, ATCICR, ADICR)
 The internal interrupt control registers (TMnICR, TBICR, SCnICR, ATCICR, ADICR) control the interrupt levels of internal interrupts, timer interrupts, serial interrupts, A/D conversion complete interrupts, and interrupt request/enable.

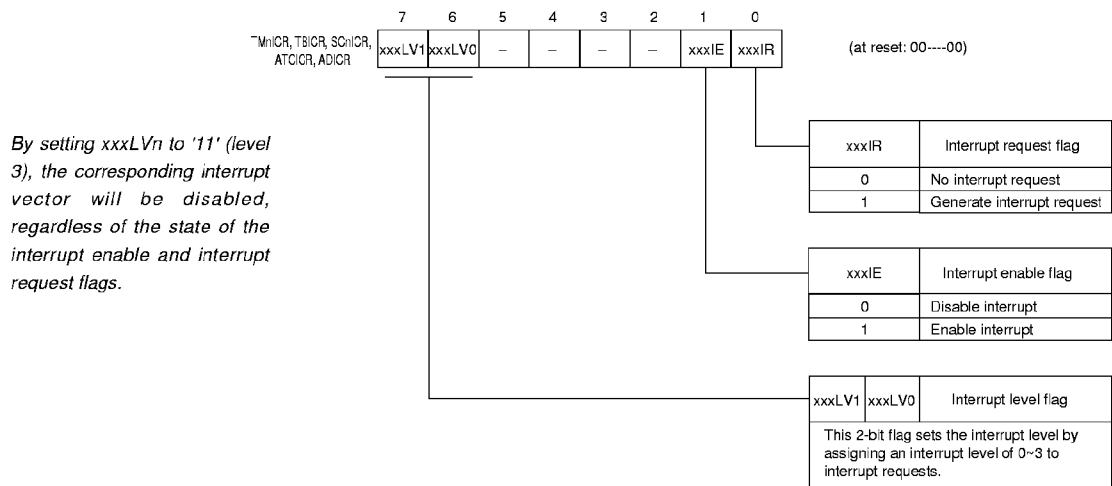

Figure 2-4-4 Internal Interrupt Control Registers (TMnICR, TBICR, SCnICR, ATCICR, ADICR: X'03FE4'~X'03FEA', X'03FEE'~X'03FF4', R/W)

2-5 Reset

The CPU contents are reset and registers are initialized when the $\overline{\text{RST}}$ pin is pulled to low.

■ Initiating a Reset

There are two methods to initiate a reset.

- (1) Drive the $\overline{\text{RST}}$ pin low for at least four clock cycles.

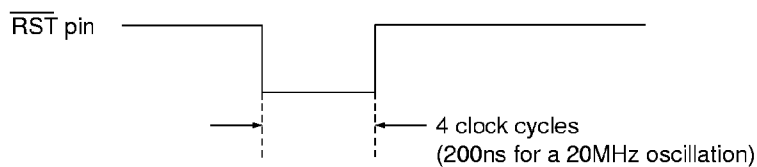

Figure 2-5-1 Minimum Reset Pulse Width

For the reset to be stable, the low pulse must be maintained for at least four clock cycles. However, it is important to minimize noise, since a reset may occur in a smaller number of clock cycles.

- (2) Set bit 7 (P2OUT7 flags) of the P2OUT register to "0." After reset is released, the P2OUT flag will be "1."

■ Releasing the Reset

When the $\overline{\text{RST}}$ pin changes from low to high, an internal 15-bit counter begins counting at the oscillation clock frequency. The interval from when this counter begins counting until it overflows is known as the stabilization wait time. After waiting for this amount of time, the internal reset is released and the CPU begins operation.

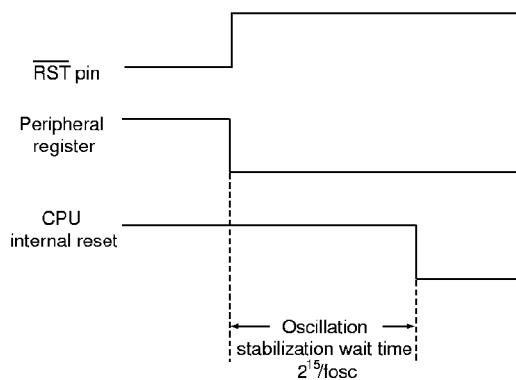

Figure 2-5-2 Reset Release Sequence



When returning from the STOP mode is terminating, the software can use the DLYCTR register to select an oscillation stabilization wait time of 0, $2^7/f_{osc}$, $2^{11}/f_{osc}$, or $2^{15}/f_{osc}$.

Chapter 3 Port Functions



3-1 Overview

A total of 71 pins on the MN101C01D, including those shared with special function pins, are allocated for the 10 ports of P0~P8, and PA.

Each I/O port is assigned according to the special function register area in memory. I/O ports are operated in byte or bit units in the same way as RAM.



For each I/O port, the PnOUT register (port n output register) that sets the output value is assigned to memory address X'3F1n', and the PnIN register (port n input register) from which the input value is monitored is assigned to memory address X'3F2n'.

- This I/O control is valid even when special functions are selected for the dual function pins.
- However, when set to the processor mode, registers cannot be used to control the I/O of P06, P50~P54, P60~P67, P70~P77, and P80~P87.

Table 3-1-1 Status When Port Is Reset (single-chip mode)

Port	I/O Mode	Pull-up/Pull-down Resistor	I/O Port or Special Function
Port 0	Input mode	No pull-up resistor	I/O port
Port 1	Input mode	No pull-up resistor	I/O port
Port 2	Input mode	No pull-up resistor	I/O port
Port 3	Input mode	No pull-up resistor	I/O port
Port 4	Input mode	No pull-up resistor	I/O port
Port 5	Input mode	No pull-up resistor	I/O port
Port 6	Input mode	No pull-up resistor	I/O port
Port 7	Input mode	No pull-up/pull-down resistors	I/O port
Port 8	Input mode	No pull-up/pull-down resistors	I/O port
Port A	Input mode	No pull-up/pull-down resistors	I/O port

Table 3-1-2 Status When Port Is Reset (processor mode)

Port	I/O Mode	Pull-up/Pull-down Resistor	I/O Port or Special Function
Port 0*	Input mode	No pull-up resistor	I/O port
Port 1	Input mode	No pull-up resistor	I/O port
Port 2	Input mode	No pull-up resistor	I/O port
Port 3	Input mode	No pull-up resistor	I/O port
Port 4	Input mode	No pull-up resistor	I/O port
Port 5	Output mode	Pins \overline{WE} , \overline{RE} , \overline{CS} , A16, A17 are enabled.	
Port 6	Output mode	Pins A0~A7 are enabled.	
Port 7	Output mode	Pins A8~A15 are enabled.	
Port 8	Input mode	Pins D0~D7 are enabled.	
Port A	Input mode	No pull-up/pull-down resistors	I/O port

*P06 enables the \overline{DK} pin (input mode).

■ Port 0 (P0)

7-bit CMOS tri-state I/O port.

Table 3-1-3 Port 0 Functions

Pin Name	Type	Dual Function	Description
P00~P06	I/O	SBO0(TXD), SBI0(RXD), SBT0,SBO1, SBI1,SBT1, DK̄(BUZZER)	Each bit can be set individually as either an input or output by the P0DIR register. A pull-up resistor for each bit can be selected individually by the P0PLU register. At reset, the input mode is selected and pull-up resistors are disabled (high impedance output).

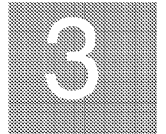

■ Port 1 (P1)

5-bit CMOS tri-state I/O port.

Table 3-1-4 Port 1 Functions

Pin Name	Type	Dual Function	Description
P10~P14	I/O	TM0IO (RMOU), TM1IO~TM4IO	Each bit can be set individually as either an input or output by the P1DIR register. A pull-up resistor for each bit can be selected individually by the P1PLU register. At reset, the input mode is selected and pull-up resistors are disabled (high impedance output).

■ Port 2 (P2)

5-bit CMOS tri-state input port.

Table 3-1-5 Port 2 Functions

Pin Name	Type	Dual Function	Description
P20~P24	Input	IRQ0, IRQ1(SENS), IRQ2~4	A pull-up resistor for each bit can be selected individually by the P2PLU register. At reset, the input mode pull-up resistors are disabled (high impedance output).

■ Port 3 (P3)

8-bit CMOS tri-state I/O port.

Table 3-1-6 Port 3 Functions

Pin Name	Type	Dual Function	Description
P30~P37	I/O	SBO2,SB12, SBT2, \overline{BR} , \overline{BG} , \overline{LDDMA} , \overline{STDMA} , \overline{DKDMA}	Each bit can be set individually as either an input or output by the P3DIR register. A pull-up resistor for each bit can be selected individually by the P3PLU register. At reset, the input mode pull-up resistors are disabled (high impedance output).

■ Port 4 (P4)

8-bit CMOS tri-state I/O port.

Table 3-1-7 Port 4 Functions

Pin Name	Type	Dual Function	Description
P40~P47	I/O	KEY0~7	Each bit can be set individually as either an input or output by the P4DIR register. A pull-up resistor for each bit can be selected individually by the P4PLU register. At reset, the input mode pull-up resistors are disabled (high impedance output).

■ Port 5 (P5)

5-bit CMOS tri-state I/O port.

Table 3-1-8 Port 5 Functions

Pin Name	Type	Dual Function	Description
P50~P54	I/O	$\overline{WE}, \overline{RE}, \overline{CS}$, A16,A17	Each bit can be set individually as either an input or output by the P5DIR register. A pull-up resistor for each bit can be selected individually by the P5PLU register. At reset, when single-chip mode is selected, the input mode pull-up resistors for P50~P54 are disabled (high impedance output). During processor mode, \overline{WE} , \overline{RE} , \overline{CS} , A16, and A17 are selected.

■ Port 6 (P6)

8-bit CMOS tri-state I/O port.

Table 3-1-9 Port 6 Functions

Pin Name	Type	Dual Function	Description
P60~P67	I/O	A0~A7	Each bit can be set individually as either an input or output by the P6DIR register. A pull-up resistor for each bit can be selected individually by the P6PLU register. At reset, when single chip mode is selected, the input mode pull-up resistors for P60~P67 are disabled (high impedance output). During processor mode, output mode is selected for A0~A7.

■ Port 7 (P7)

8-bit CMOS tri-state I/O port.

Table 3-1-10 Port 7 Functions

Pin Name	Type	Dual Function	Description
P70~P77	I/O	A8~A15	Each individual bit can be switched to an input or output by the P7DIR register. A pull-up or pull-down resistor for each bit can be selected individually by the P7PLU register. However, pull-up and pull-down resistors cannot be mixed. At reset, when single chip mode is selected, the input mode pull-up resistors for P70~P77 are disabled (high impedance output). During processor mode, A8~A15 (address signals) are set to output mode.

■ Port 8 (P8)

8-bit CMOS tri-state I/O port.

Table 3-1-11 Port 8 Functions

Pin Name	Type	Dual Function	Description
P80~P87	I/O	LED0~7 (D0~D7)	Each individual bit can be switched to an input or output by the P8DIR register. A pull-up resistor for each bit can be selected individually by the P8PLU register. When configured as outputs, it is possible to drive segments. At reset, when single chip mode is selected, the input mode pull-up resistors for P80~P87 are disabled (high impedance output). During processor mode, D0~D7 (data signals) are set to high impedance outputs.

■ Port A (PA)

8-bit CMOS tri-state input port.

Table 3-1-12 Port A Functions

Pin Name	Type	Dual Function	Description
PA0~PA7	Input	AN0~AN7	A pull-up or pull-down resistor for each bit can be selected individually by the PAPLUD register. However, pull-up and pull-down resistors cannot be mixed. At reset, the input mode pull-up resistors for PA0~PA7 are disabled.

3-2 Port Control Registers

3-2-1 Overview

Forty-three registers control the I/O ports. See table 3-2-1.

Table 3-2-1 I/O Port Control Registers (1/2)

Name	Address	R/W	Function
P0OUT	X'03F10'	R/W	Port 0 output register
P1OUT	X'03F11'	R/W	Port 1 output register
P2OUT	X'03F12'	R/W	Port 2 output register
P3OUT	X'03F13'	R/W	Port 3 output register
P4OUT	X'03F14'	R/W	Port 4 output register
P5OUT	X'03F15'	R/W	Port 5 output register
P6OUT	X'03F16'	R/W	Port 6 output register
P7OUT	X'03F17'	R/W	Port 7 output register
P8OUT	X'03F18'	R/W	Port 8 output register
SYSMO	X'03F1F'	R/W	Synchronous output control register
P0IN	X'03F20'	R	Port 0 input register
P1IN	X'03F21'	R	Port 1 input register
P2IN	X'03F22'	R	Port 2 input register
P3IN	X'03F23'	R	Port 3 input register
P4IN	X'03F24'	R	Key interrupt control register
P5IN	X'03F25'	R	Port 5 input register
P6IN	X'03F26'	R	Port 6 input register
P7IN	X'03F27'	R	Port 7 input register
P8IN	X'03F28'	R	Port 8 input register
PAIN	X'03F2A'	R	Port A input register
P0DIR	X'03F30'	R/W	Port 0 direction control register
P1DIR	X'03F31'	R/W	Port 1 direction control register
P3DIR	X'03F33'	R/W	Port 3 direction control register

Table 3-2-1 I/O Port Control Registers (2/2)

Name	Address	R/W	Function
P4DIR	X'03F34'	R/W	Port 4 direction control register
P5DIR	X'03F35'	R/W	Port 5 direction control register
P6DIR	X'03F36'	R/W	Port 6 direction control register
P7DIR	X'03F37'	R/W	Port 7 direction control register
P8DIR	X'03F38'	R/W	Port 8 direction control register
P1OMD	X'03F39'	R/W	Port 1 output mode register
PAIMD	X'03F3A'	R/W	Port A input mode register
P4IMD	X'03F3C'	R/W	Key interrupt control register
P0PLU	X'03F40'	R/W	Port 0 pull-up control register
P1PLU	X'03F41'	R/W	Port 1 pull-up control register
P2PLU	X'03F42'	R/W	Port 2 pull-up control register
P3PLU	X'03F43'	R/W	Port 3 pull-up control register
P4PLU	X'03F44'	R/W	Port 4 pull-up control register
P5PLU	X'03F45'	R/W	Port 5 pull-up control register
P6PLU	X'03F46'	R/W	Port 6 pull-up control register
P7PLUD	X'03F47'	R/W	Port 7 pull-up/pull-down control register
P8PLU	X'03F48'	R/W	Port 8 pull-up control register
PAPLUD	X'03F4A'	R/W	Port A pull-up/pull-down control register
FLOAT1	X'03F4B'	R/W	Pin control register 1
FLOAT2	X'03F4C'	R/W	Pin control register 2

	7	6	5	4	3	2	1	0	
P0OUT	—	P0OUT6	P0OUT5	P0OUT4	P0OUT3	P0OUT2	P0OUT1	P0OUT0	(at reset: -0000000)
P1OUT	—	—	—	P1OUT4	P1OUT3	P1OUT2	P1OUT1	P1OUT0	(at reset: ---00000)
P2OUT	P2OUT7	—	—	—	—	—	—	—	(at reset: 1-----)
P3OUT	P3OUT7	P3OUT6	P3OUT5	P3OUT4	P3OUT3	P3OUT2	P3OUT1	P3OUT0	(at reset: 00000000)
P0IN	—	P0IN6	P0IN5	P0IN4	P0IN3	P0IN2	P0IN1	P0IN0	(at reset: XXXXXXXX)
P1IN	—	—	—	P1IN4	P1IN3	P1IN2	P1IN1	P1IN0	(at reset: ---XXXXX)
P2IN	—	—	—	P2IN4	P2IN3	P2IN2	P2IN1	P2IN0	(at reset: ---XXXXX)
P3IN	P3IN7	P3IN6	P3IN5	P3IN4	P3IN3	P3IN2	P3IN1	P3IN0	(at reset: XXXXXXXX)
P0DIR	—	P0DIR6	P0DIR5	P0DIR4	P0DIR3	P0DIR2	P0DIR1	P0DIR0	(at reset: -0000000)
P1DIR	—	—	—	P1DIR4	P1DIR3	P1DIR2	P1DIR1	P1DIR0	(at reset: ---00000)
P3DIR	P3DIR7	P3DIR6	P3DIR5	P3DIR4	P3DIR3	P3DIR2	P3DIR1	P3DIR0	(at reset: 00000000)
P1OMD	—	—	—	P14TCO	P13TCO	P12TCO	P11TCO	P10TCO	(at reset: 00000000)
P0PLU	—	P0PLU6	P0PLU5	P0PLU4	P0PLU3	P0PLU2	P0PLU1	P0PLU0	(at reset: -0000000)
P1PLU	—	—	—	P1PLU4	P1PLU3	P1PLU2	P1PLU1	P1PLU0	(at reset: ---00000)
P2PLU	—	—	—	P2PLU4	P2PLU3	P2PLU2	P2PLU1	P2PLU0	(at reset: ---00000)
P3PLU	P3PLU7	P3PLU6	P3PLU5	P3PLU4	P3PLU3	P3PLU2	P3PLU1	P3PLU0	(at reset: 00000000)

Figure 3-2-1 Port Control Registers (1/3)

	7	6	5	4	3	2	1	0	
P4OUT	P4OUT7	P4OUT6	P4OUT5	P4OUT4	P4OUT3	P4OUT2	P4OUT1	P4OUT0	(at reset: 00000000)
P5OUT	—	—	—	P5OUT4	P5OUT3	P5OUT2	P5OUT1	P5OUT0	(at reset: ---00000)
P6OUT	P6OUT7	P6OUT6	P6OUT5	P6OUT4	P6OUT3	P6OUT2	P6OUT1	P6OUT0	(at reset: 00000000)
P4IN	P4IN7	P4IN6	P4IN5	P4IN4	P4IN3	P4IN2	P4IN1	P4IN0	(at reset: XXXXXXXX)
P5IN	—	—	—	P5IN4	P5IN3	P5IN2	P5IN1	P5IN0	(at reset: ---XXXXX)
P6IN	P6IN7	P6IN6	P6IN5	P6IN4	P6IN3	P6IN2	P6IN1	P6IN0	(at reset: XXXXXXXX)
P4DIR	P4DIR7	P4DIR6	P4DIR5	P4DIR4	P4DIR3	P4DIR2	P4DIR1	P4DIR0	(at reset: 00000000)
P5DIR	—	—	—	P5DIR4	P5DIR3	P5DIR2	P5DIR1	P5DIR0	(at reset: ---00000)
P6DIR	P6DIR7	P6DIR6	P6DIR5	P6DIR4	P6DIR3	P6DIR2	P6DIR1	P6DIR0	(at reset: 00000000)
P4IMD	IRQ4SEL	—	—	—	P4KYEN4	P4KYEN3	P4KYEN2	P4KYEN1	(at reset: 0---0000)
P4PLU	P4PLU7	P4PLU6	P4PLU5	P4PLU4	P4PLU3	P4PLU2	P4PLU1	P4PLU0	(at reset: 00000000)
P5PLU	—	—	—	P5PLU4	P5PLU3	P5PLU2	P5PLU1	P5PLU0	(at reset: ---00000)
P6PLU	P6PLU7	P6PLU6	P6PLU5	P6PLU4	P6PLU3	P6PLU2	P6PLU1	P6PLU0	(at reset: 00000000)

Figure 3-2-1 Port Control Registers (2/3)

	7	6	5	4	3	2	1	0	
P7OUT	P7OUT7	P7OUT6	P7OUT5	P7OUT4	P7OUT3	P7OUT2	P7OUT1	P7OUT0	(at reset: 00000000)
P8OUT	P8OUT7	P8OUT6	P8OUT5	P8OUT4	P8OUT3	P8OUT2	P8OUT1	P8OUT0	(at reset: 00000000)
P7IN	P7IN7	P7IN6	P7IN5	P7IN4	P7IN3	P7IN2	P7IN1	P7IN0	(at reset: XXXXXXXXX)
P8IN	P8IN7	P8IN6	P8IN5	P8IN4	P8IN3	P8IN2	P8IN1	P8IN0	(at reset: XXXXXXXXX)
PAIN	PAIN7	PAIN6	PAIN5	PAIN4	PAIN3	PAIN2	PAIN1	PAIN0	(at reset: XXXXXXXXX)
P7DIR	P7DIR7	P7DIR6	P7DIR5	P7DIR4	P7DIR3	P7DIR2	P7DIR1	P7DIR0	(at reset: 00000000)
P8DIR	P8DIR7	P8DIR6	P8DIR5	P8DIR4	P8DIR3	P8DIR2	P8DIR1	P8DIR0	(at reset: 00000000)
PAIMD	PAAIN7	PAAIN6	PAAIN5	PAAIN4	PAAIN3	PAAIN2	PAAIN1	PAAIN0	(at reset: 00000000)
SYSDM	SYSDM7	SYSDM6	SYSDM5	SYSDM4	SYSDM3	SYSDM2	SYSDM1	SYSDM0	(at reset: 00000000)
P7PLUD	P7PLUD7	P7PLUD6	P7PLUD5	P7PLUD4	P7PLUD3	P7PLUD2	P7PLUD1	P7PLUD0	(at reset: 00000000)
P8PLU	P8PLU7	P8PLU6	P8PLU5	P8PLU4	P8PLU3	P8PLU2	P8PLU1	P8PLU0	(at reset: 00000000)
PAPLUD	PAPLUD7	PAPLUD6	PAPLUD5	PAPLUD4	PAPLUD3	PAPLUD2	PAPLUD1	PAPLUD0	(at reset: 00000000)

Figure 3-2-1 Port Control Registers (3/3)

3-2-2 I/O Port Control Registers

This section describes the special function registers that control the MN101C01D's I/O ports.

■ Data Registers

• PnOUT registers

Data registers to output to the ports.

Data written to these registers is output from the ports.

0	Low (Vss level) is output.
1	High (Vdd level) is output.

• PnIN registers (Read-only registers)

Data registers to input data from the ports.

The value of data at the pins can be input by reading these registers.

0	Pin is low.
1	Pin is high.

Input and output registers are mapped to separate addresses.

To use these ports for I/O, configure them as I/O ports in the PnOMD/PnIMD registers, described in this section.

■ Direction Control Registers

• PnDIR registers

These registers set the port for use as an input or output.

0	Input mode
1	Output mode

■ Pull-up/Pull-down Resistor Control Registers

• PnPLU registers

These register settings determine whether internal pull-up resistors are added to the ports.

0	No pull-up resistor
1	Pull-up resistor

• PnPLUD registers

These register settings determine whether internal pull-up or pull-down resistors are added to the ports.

0	No pull-up resistor
1	Pull-up resistor

■ Synchronous Output Control Register

• SYSMD register

This register determines whether the port pins (P77~P70) are used as I/O ports or as synchronous output pins.

If used as synchronous output pins, the P7DIR, P7PLUD, FLOAT1, and other registers must be set.

0	I/O port
1	Synchronous output pin

■ Port Output/Input Mode Registers

• PnOMD/PnIMD registers

These register settings determine whether the port pins are used as I/O ports or as special function pins (dual function).

If the special (dual) functions used, the PnDIR, PnPLU, PnPLUD, and other registers must be set.

0	I/O port
1	Special function pin

■ Key Interrupt Control Register

• P4IMD register

P4 pins can be selected in 2-bit units as key input pins. If even one of the selected ports falls to a low level, a key input interrupt will be generated at that falling edge.

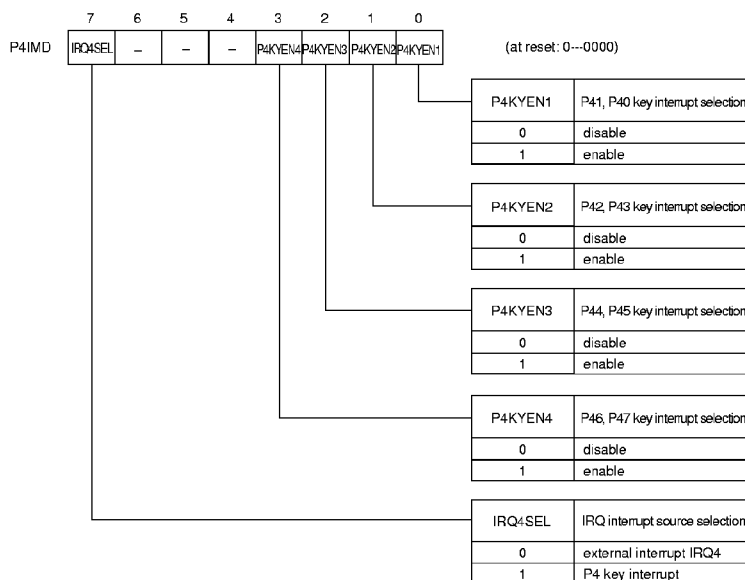

Figure 3-2-2 Key Interrupt Control Register (P4IMD)

!
Setting the PAIMD register prevents unnecessary current from flowing in a pin when an intermediate voltage (analog voltage) is applied to the pin.

!
Set the REDG4 flag (bit 5 of the IRQ4ICR) to "0" (falling edge) when P4 key interrupts are to be used.

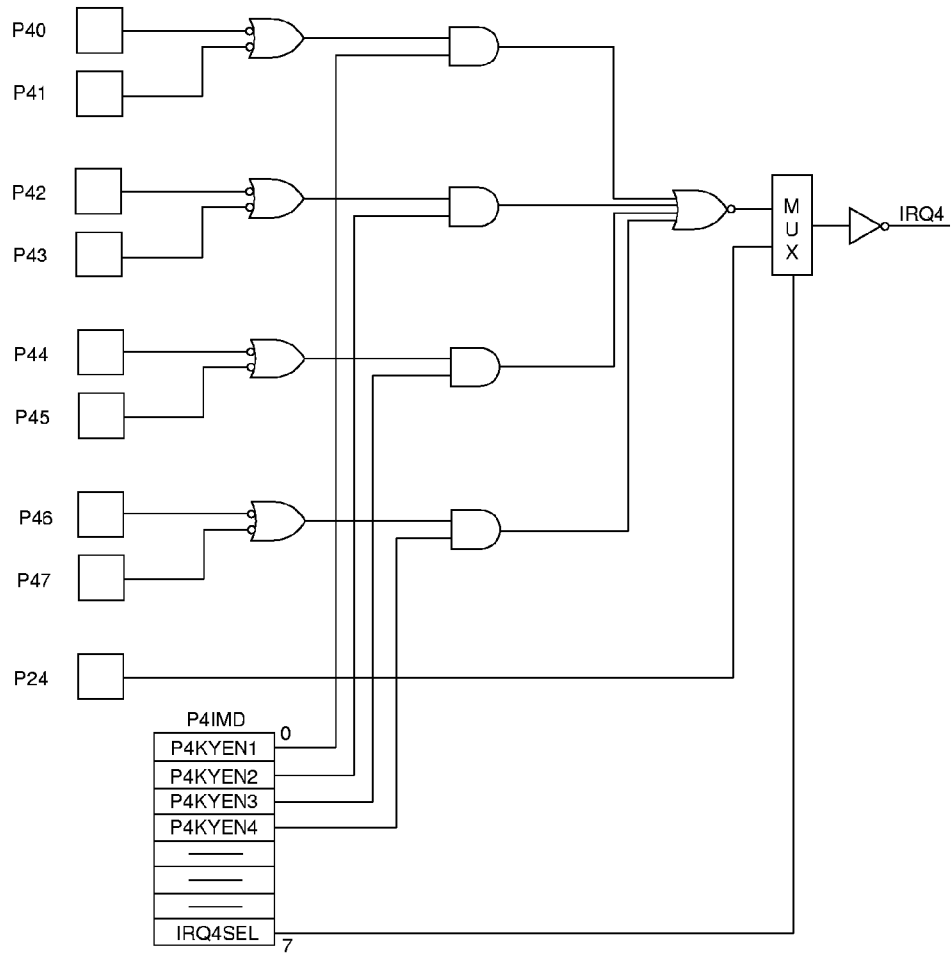

Figure 3-2-3 Key Interrupt Control Block Diagram

■ Pin Control Registers

• FLOAT1 registers

This register specifies whether the resistors attached to pins P7 and PA are pull-up resistors or pull-down resistors.

In addition, this register selects either zero cross input or Schmitt trigger input for pin P21.

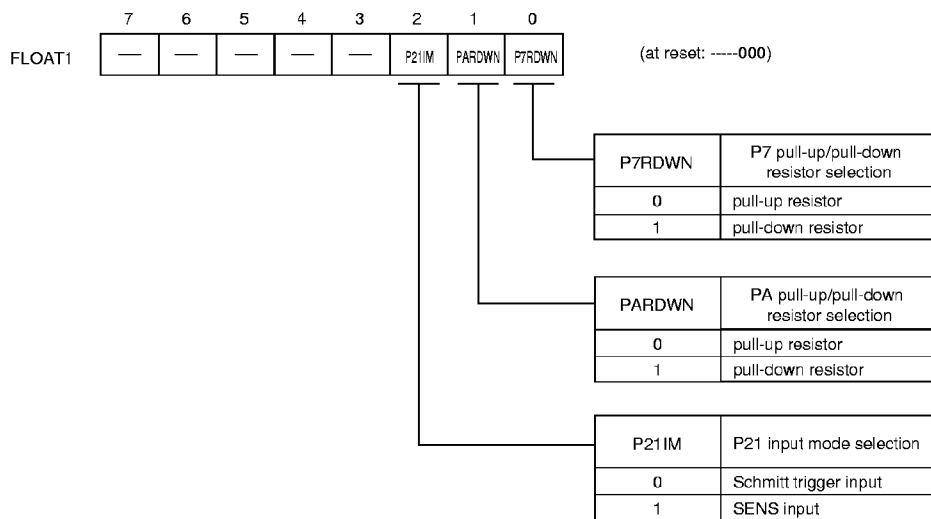

Figure 3-2-4 Pin Control Register 1 (FLOAT1: X'03F4B', R/W)

• FLOAT2 registers

This register selects the output event when P7 is used as a synchronous output.

External interrupts (IRQ2), timer 1 interrupts, timer 2 interrupts or timer 4 interrupts can be selected as the output event.

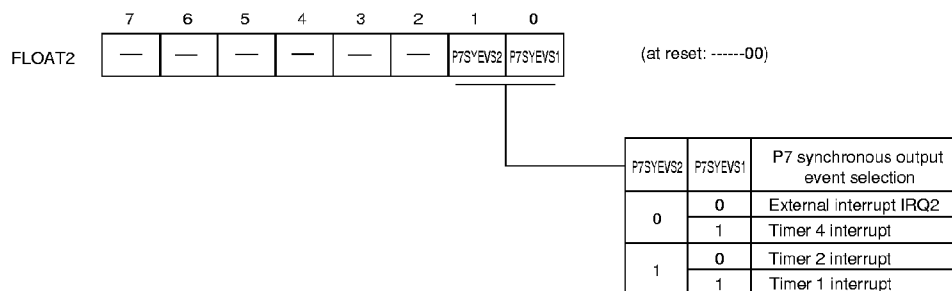
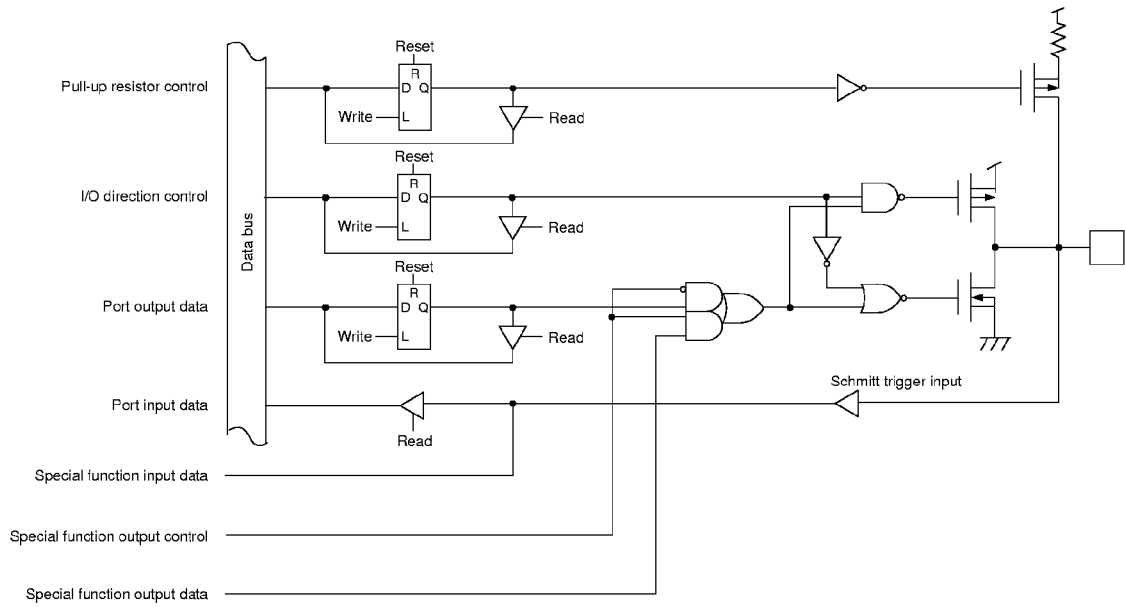

Figure 3-2-5 Pin Control Register 2 (FLOAT2: X'03F4C', R/W)

3-3 I/O Port Configuration and Functions

■ P00,P02,P03,P05,P10~P14,P30,P32



		P00	P02	P03	P05	P10	P11	P12	P13	P14	P30	P32
Pull-up resistor control	Control bit	POPLU0	POPLU2	POPLU3	POPLU5	P1PLU0	P1PLU1	P1PLU2	P1PLU3	P1PLU4	E3PLU0	P3PLU2
	Register (address)	POPLC (X'03140')					P1PLU (X'03141')				P3PLU (X'03143')	
I/O direction control	Control bit	PODIR0	PODIR2	PODIR3	PODIR5	P1DIR0	P1DIR1	P1DIR2	P1DIR3	P1DIR4	P3DIR0	P3DIR2
	Register (address)	PODIR (X'03F30')					P1DIR (X'03F31')				P3DIR (X'03F33')	
Port output	Control bit	POOUT0	POOUT2	POOUT3	POOUT5	P1OUT0	P1OUT1	P1OUT2	P1OUT3	P1OUT4	P3OUT0	P3OUT2
	Register (address)	POOUT (X'03F10')					P1OUT (X'03F11')				P3OUT (X'03F13')	
Port input	Control bit	POIN0	POIN2	POIN3	POIN5	P1IN0	P1IN1	P1IN2	P1IN3	P1IN4	P3IN0	P3IN2
	Register (address)	POIN (X'03F20')					P1IN (X'03F21')				P3IN (X'03F23')	
Output format control	Control bit	SC0SBOM	SC0SBTM	SC1SBOM	SC1SBTM						SC2SBOM	SC2SBTM
	Register (address)	SC0MD3 (X'03F53')		SC1MD1 (X'03F58')								SC2MD1 (X'03F5B')
Special function input	Special function					TM0IO	TM1IO	TM2IO	TM3IO	TM4IO		
Special function output control (1)	Special function	SB00(TXD)	SB10	SB01	SB11	Special function PORT	Special function PORT	Special function PORT	Special function PORT	Special function PORT	SBO2	SBT2
	Register (address)	SC0SBOS		SC1SBOS		P10TCO	P11TCO	P12TCO	P13TCO	P14TCO	SC2SBOS	SC2SBTS
Special function input	Special function					P10MD (X'03F39')						SC2MD1 (X'03F5B')
Special function output control (2)	Special function	SB00(TXD)				RMOUT						
	Control bit	SC0CMD				Special function PORT						
	Register (address)	SC0CTR (X'03F54)				RMCTR (X'3F89)						

* The TM0RM flag of the RMCTR register is used to switch between remote control output and timer output.

Figure 3-3-1 Configuration and Functions of P00, P02, P03, P05, P10~P14, P30, P32

■ P01,P04,P06,P31

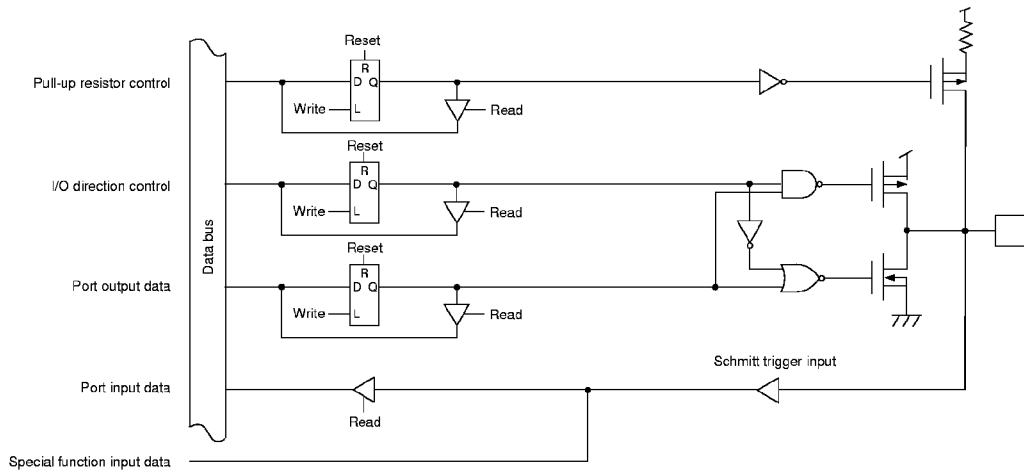

		P01	P04	P06	P31
Pull-up resistor control	Control bit	P0PLU1	P0PLU4	P0PLU6	P3PLU1
	Register (address)	P0PLU (X'03F40')			P3PLU (X'03F43')
I/O direction control	Control bit	P0DIR1	P0DIR4	P0DIR6	P3DIR1
	Register (address)	P0DIR (X'03F30')			P3DIR (X'03F33')
Port output	Control bit	P0OUT1	P0OUT4	P0OUT6	P3OUT1
	Register (address)	P0OUT (X'03F10')			P3OUT (X'03F13')
Port input	Control bit	P0IN1	P0IN4	P0IN6	P3IN1
	Register (address)	P0IN (X'03F20')			P3IN (X'03F23')
Special function input	Special function	SBI0/RXD	SBI1	\overline{DK}	SBI2
Special function output control (1)	Special function	————	————	BUZZER	————
	Control bit	————	————	BUZZOE	————
	Register (address)	————	————	DLYCTR (X'03F03')	————
Special function input	Special function				
Special function output control (2)	Special function				
	Control bit				
	Register (address)				

Figure 3-3-2 Configuration and Functions of P01, P04, P06, P31

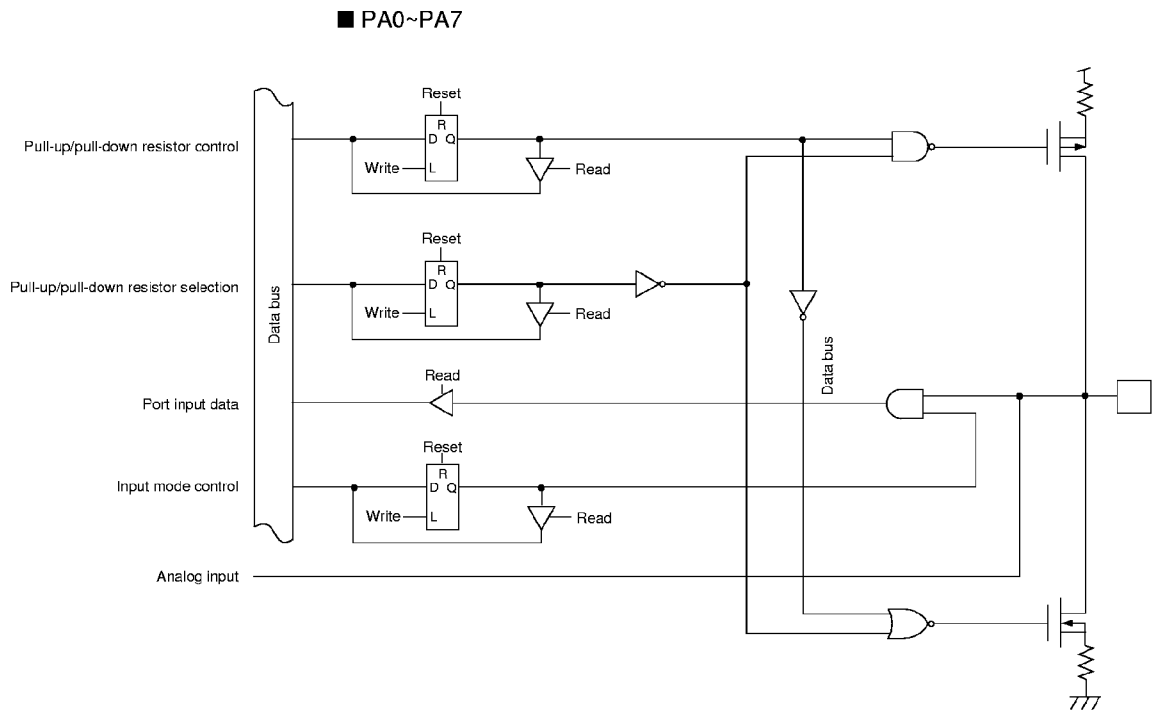

		PA0	PA1	PA2	PA3	PA4	PA5	PA6	PA7
Pull-up resistor control	Control bit	PAPLUD0	PAPLUD1	PAPLUD2	PAPLUD3	PAPLUD4	PAPLUD5	PAPLUD6	PAPLUD7
	Register (address)	PAPLUD (X'03F4A')							
Pull-up/pull-down resistor control	Control bit	PARDWN							
	Register (address)	FLOAT1 (X'03F4B')							
Input mode control	Control bit	PAAIN0	PAAIN1	PAAIN2	PAAIN3	PAAIN4	PAAIN5	PAAIN6	PAAIN7
	Register (address)	PAIMD (X'03F3A')							
Port input	Control bit	PAIN0	PAIN1	PAIN2	PAIN3	PAIN4	PAIN5	PAIN6	PAIN7
	Register (address)	PAIN (X'03F2A')							
Special function input	Special function	AN0	AN1	AN2	AN3	AN4	AN5	AN6	AN7

Figure 3-3-3 Configuration and Functions of PA0~PA7

■ Pin Configuration for P20, P22~P24

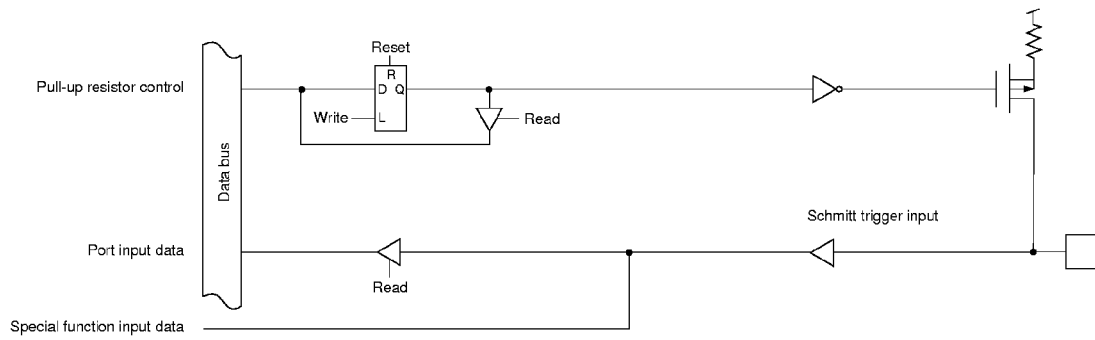

		P20	P22	P23	P24
Pull-up resistor control	Control bit	P2PLU0	P2PLU2	P2PLU3	P2PLU4
	Register (address)	P2PLU (x'03F42')			
Port input	Control bit	P2IN0	P2IN2	P2IN3	P2IN4
	Register (address)	P2IN (x'03F22')			
Special function input	Interrupt input	IRQ0	IRQ2	IRQ3	IRQ4

Figure 3-3-4 Configuration and Functions of P20, P22~P24

■ P21

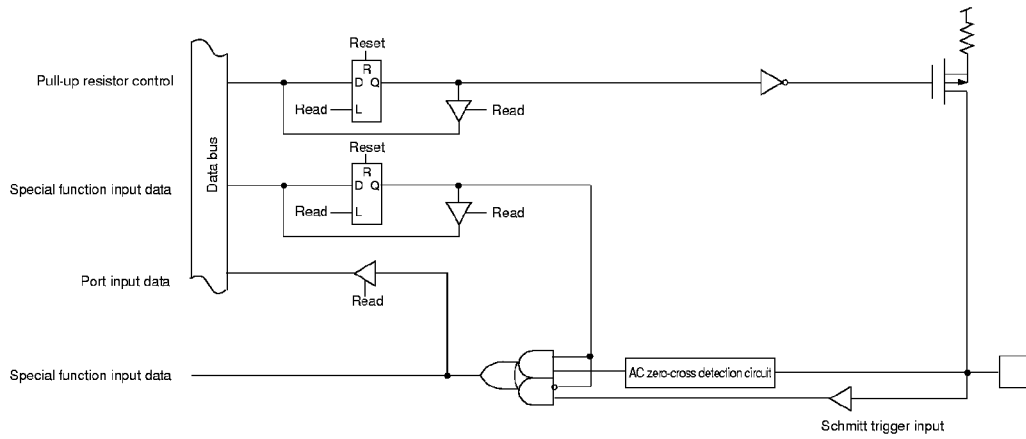

		P21
Pull-up resistor control	Control bit	P2PLU1
	Register (address)	P2PLU (x'03F42')
Port input	Control bit	P2IN1
	Register (address)	P2IN (x'03F22')
Special function input selection	Special function	SENS
	Control bit	P2IIM
	Register (address)	FLOAT1 (x'03F4B')

Figure 3-3-5 Configuration and Functions of P21

■ P27

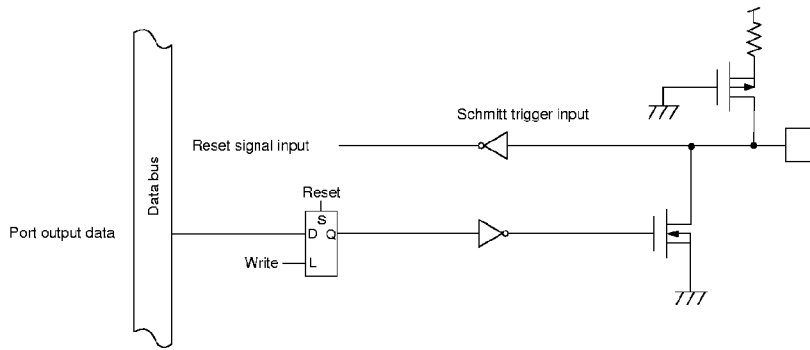

		P27
Special input		\overline{RST}
Special function output	Special function	Soft reset output
	Control bit	P2OUT7
	Register (address)	P2OUT (x'03F12')

Figure 3-3-6 Configuration and Functions of P27

■ P70~P77

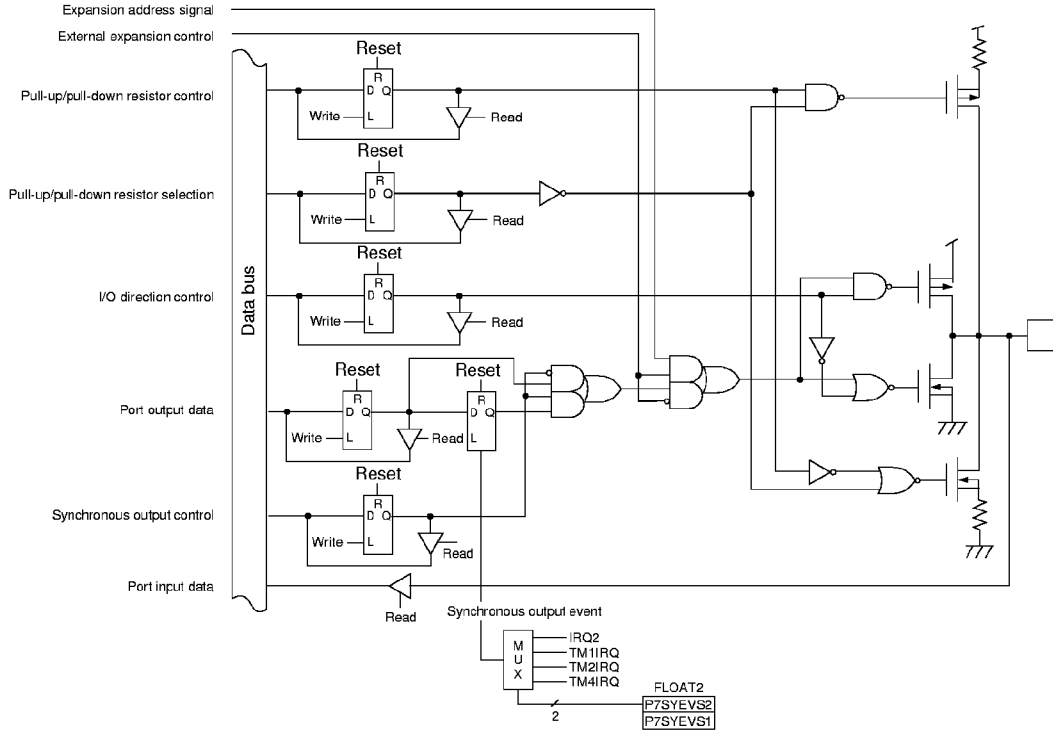

		P70	P71	P72	P73	P74	P75	P76	P77
Pull-up/ pull-down resistor control	Control bit	P7PLUD0	P7PLUD1	P7PLUD2	P7PLUD3	P7PLUD4	P7PLUD5	P7PLUD6	P7PLUD7
	Register (address)	P7PLUD (X'03F47')							
Pull-up/ pull-down resistor control	Control bit	P7RDWN							
	Register (address)	FLOAT1 (X'03F4B')							
I/O direction control	Control bit	P7DIR0	P7DIR1	P7DIR2	P7DIR3	P7DIR4	P7DIR5	P7DIR6	P7DIR7
	Register (address)	P7DIR (X'03F37')							
Port input	Control bit	P7IN0	P7IN1	P7IN2	P7IN3	P7IN4	P7IN5	P7IN6	P7IN7
	Register (address)	P7IN (X'03F27')							
Port output	Control bit	P7OU10	P7OU11	P7OUT2	P7OUT3	P7OU14	P7OU15	P7OU16	P7OU17
	Register (address)	P7OUT (X'03F17')							
Special function output control (1)	Special function	PORT/Synchronous output							
	Control bit	SYSDM0	SYSDM1	SYSDM2	SYSDM3	SYSDM4	SYSDM5	SYSDM6	SYSDM7
	Register (address)	SYSDM (X'03F1F')							
Special function output control (2)	Special function	A8	A9	A10	A11	A12	A13	A14	A15
	Control bit	MMOD pin							

Figure 3-3-7 Configuration and Functions of P70~P77

■ P33,P35,P36,P40~P47

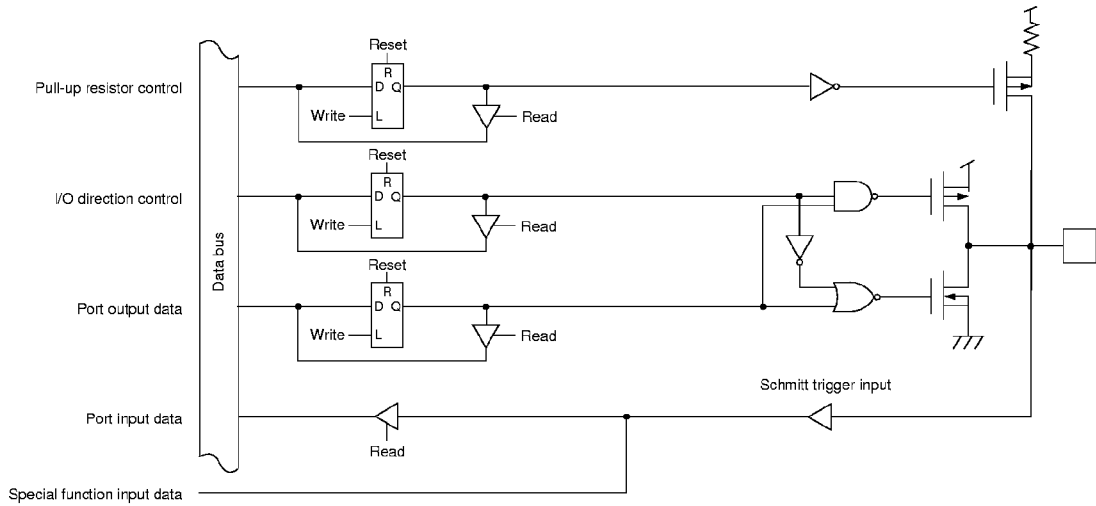

		P33	P35	P36	P40	P41	P42	P43	P44	P45	P46	P47
Pull-up resistor control	Control bit	P3PLU3	P3PLU5	P3PLU6	P4PLU0	P4PLU1	P4PLU2	P4PLU3	P4PLU4	P4PLU5	P4PLU6	P4PLU7
	Register (address)	P3PLU (x'03F43')			P4PLU (X'03F44')							
I/O direction control	Control bit	P3DIR3	P3DIR5	P3DIR6	P4DIR0	P4DIR1	P4DIR2	P4DIR3	P4DIR4	P4DIR5	P4DIR6	P4DIR7
	Register (address)	P3DIR (x'03F33')			P4DIR (X'03F34')							
Port output	Control bit	P3OUT3	P3OUT5	P3OUT6	P4OUT0	P4OUT1	P4OUT2	P4OUT3	P4OUT4	P4OUT5	P4OUT6	P4OUT7
	Register (address)	P3OUT (x'03F13')			P4OUT (X'03F14')							
Port input	Control bit	P3IN3	P3IN5	P3IN6	P4IN0	P4IN1	P4IN2	P4IN3	P4IN4	P4IN5	P4IN6	P4IN7
	Register (address)	P3IN (x'03F23')			P4IN (X'03F24')							
Special function input	Special function	BR	LDDMA	STDMA	KEY0	KEY1	KEY2	KEY3	KEY4	KEY5	KEY6	KEY7
Special function output control (1)	Special function	Key interrupt/IRQ4										
	Control bit	IRQ4SEL										
	Register (address)	P4IMD (x'03F3C')										
Special function output control (2)	Special function	—		Special function/PORT		Special function/PORT		Special function/PORT		Special function/PORT		
	Control bit	—		P4KYEN1		P4KYEN2		P4KYEN3		P4KYEN4		
	Register (address)	—		P4IMD (x'03F3C')								

Figure 3-3-8 Configuration and Functions of P33, P35, P36, P40~P47

■ P34,P37,P50~P54,P60~P67,P80~P87

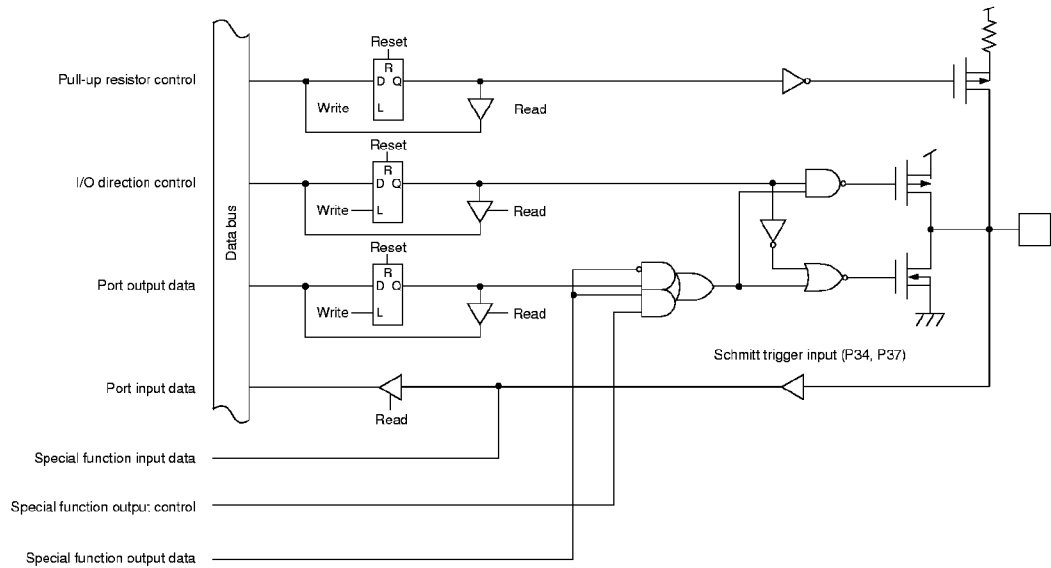

		P34	P37	P50	P51	P52	P53	P54
Pull-up resistor control	Control bit	P3PLU4	P3PLU7	P5PLU0	P5PLU1	P5PLU2	P5PLU3	P5PLU4
	Register (address)	P3PLU (x'03F43')		P5PLU (x'03F45')				
I/O direction control	Control bit	P3DIR4	P3DIR7	P5DIR0	P5DIR1	P5DIR2	P5DIR3	P5DIR4
	Register (address)	P3DIR (x'03F33')		P5DIR (x'03F35')				
Port output	Control bit	P3OUT4	P3OUT7	P5OUT0	P5OUT1	P5OUT2	P5OUT3	P5OUT4
	Register (address)	P3OUT (x'03F13')		P5OUT (x'03F15')				
Port input	Control bit	P3IN4	P3IN7	P5IN0	P5IN1	P5IN2	P5IN3	P5IN4
	Register (address)	P3IN (x'03F23')		P5IN (x'03F25')				
Special function output control	Special function	BG	DKDMA	\overline{WE}	\overline{RE}	\overline{CS}	A16	A17
	Control bit	MMOD pin						

Figure 3-3-9 Configuration and Functions of P34, P37, P50~P54

		P60	P61	P62	P63	P64	P65	P66	P67
Pull-up resistor control	Control bit	P6PLU0	P6PLU1	P6PLU2	P6PLU3	P6PLU4	P6PLU5	P6PLU6	P6PLU7
	Register (address)	P6PLU (x'03F46')							
I/O direction control	Control bit	P6DIR0	P6DIR1	P6DIR2	P6DIR3	P6DIR4	P6DIR5	P6DIR6	P6DIR7
	Register (address)	P6DIR (x'03F36')							
Port output	Control bit	P6OUT0	P6OUT1	P6OUT2	P6OUT3	P6OUT4	P6OUT5	P6OUT6	P6OUT7
	Register (address)	P6OUT (x'03F16')							
Port input	Control bit	P6IN0	P6IN1	P6IN2	P6IN3	P6IN4	P6IN5	P6IN6	P6IN7
	Register (address)	P6IN (x'03F26')							
Special function output control	Special function	A0	A1	A2	A3	A4	A5	A6	A7
	Control bit	MMOD pin							

Figure 3-3-10 Configuration and Functions of P60~67

		P80	P81	P82	P83	P84	P85	P86	P87
Pull-up resistor control	Control bit	P8PLU0	P8PLU1	P8PLU2	P8PLU3	P8PLU4	P8PLU5	P8PLU6	P8PLU7
	Register (address)	P8PLU (x'03F48')							
I/O direction control	Control bit	P8DIR0	P8DIR1	P8DIR2	P8DIR3	P8DIR4	P8DIR5	P8DIR6	P8DIR7
	Register (address)	P8DIR (x'03F38')							
Port output	Control bit	P8OUT0	P8OUT1	P8OUT2	P8OUT3	P8OUT4	P8OUT5	P8OUT6	P8OUT7
	Register (address)	P8OUT (x'03F18')							
Port input	Control bit	P8IN0	P8IN1	P8IN2	P8IN3	P8IN4	P8IN5	P8IN6	P8IN7
	Register (address)	P8IN (x'03F28')							
Special function output control	Special function	D0	D1	D2	D3	D4	D5	D6	D7
	Control bit	MMOD pin							

Figure 3-3-11 Configuration and Functions of P80~P87

Chapter 4 Timer Functions



4-1 Overview

The MN101C01D contains five 8-bit timers, one 16-bit timer, a watchdog timer, a time base timer, and circuits for remote control output and buzzer output.

Table 4-1-1 Summary of Timer Functions

	Timer 0 (8-bit)	Timer 1 (8-bit)	Timer 2 (8-bit)	Timer 3 (8-bit)	Timer 4 (16-bit)	Timer 5 (8-bit)	Time Base
Interrupt	TM0IRQ	TM1IRQ	TM2IRQ	TM3IRQ	TM4IRQ	TM5IRQ	TBIRQ
Timer operation	✓	✓	✓	✓	✓	✓	✓
Event counter	✓	✓	✓	✓	✓	—	—
Timer pulse output	✓	✓	✓	✓	✓	—	—
Serial transmission clock	✓ (SIF2)	—	—	✓ (SIF0,1)	—	—	—
Synchronous output timing generation	—	✓	✓	—	✓	—	—
PWM output	✓	—	✓	—	✓	—	—
Cascade connection	✓		✓		—	—	—
Capture function	—	—	—	—	✓	—	—
Clock source	0	fosc	fs/16	fs	fosc	fosc	fosc
	1	fs	fs/64	fs/4	fs/4	fs/4	fx
	2	fs/4	fx	fx	fs/16	fs/16	fx
	3	TM0IO input	TM1IO input	TM2IO input	TM3IO input	TM4IO input	fosc, fx/2 ¹³
Other	Remote control carrier pulse generation			Remote control carrier pulse generation	Pulse added type PWM	Not possible to temporarily halt BC	

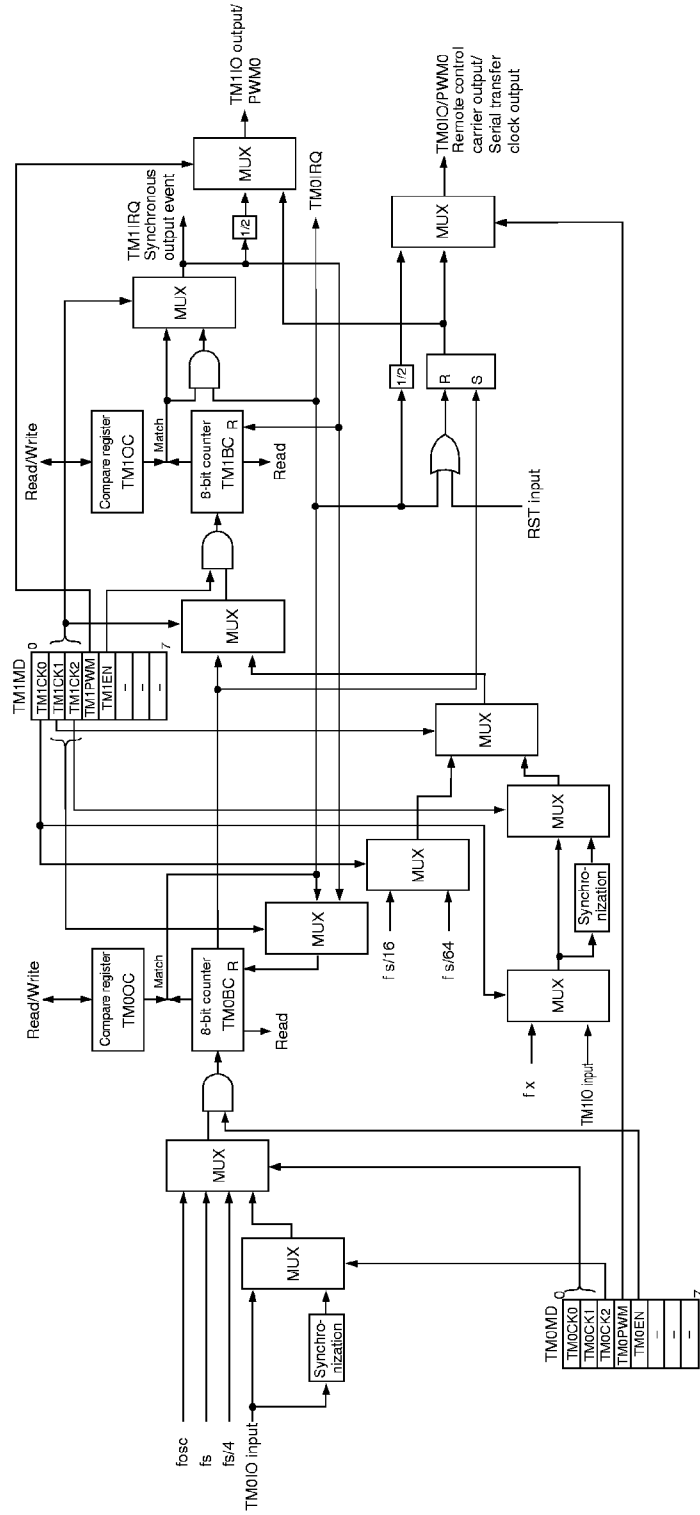
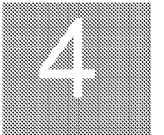

Figure 4-1-1 Timers 0, 1 Block Diagram



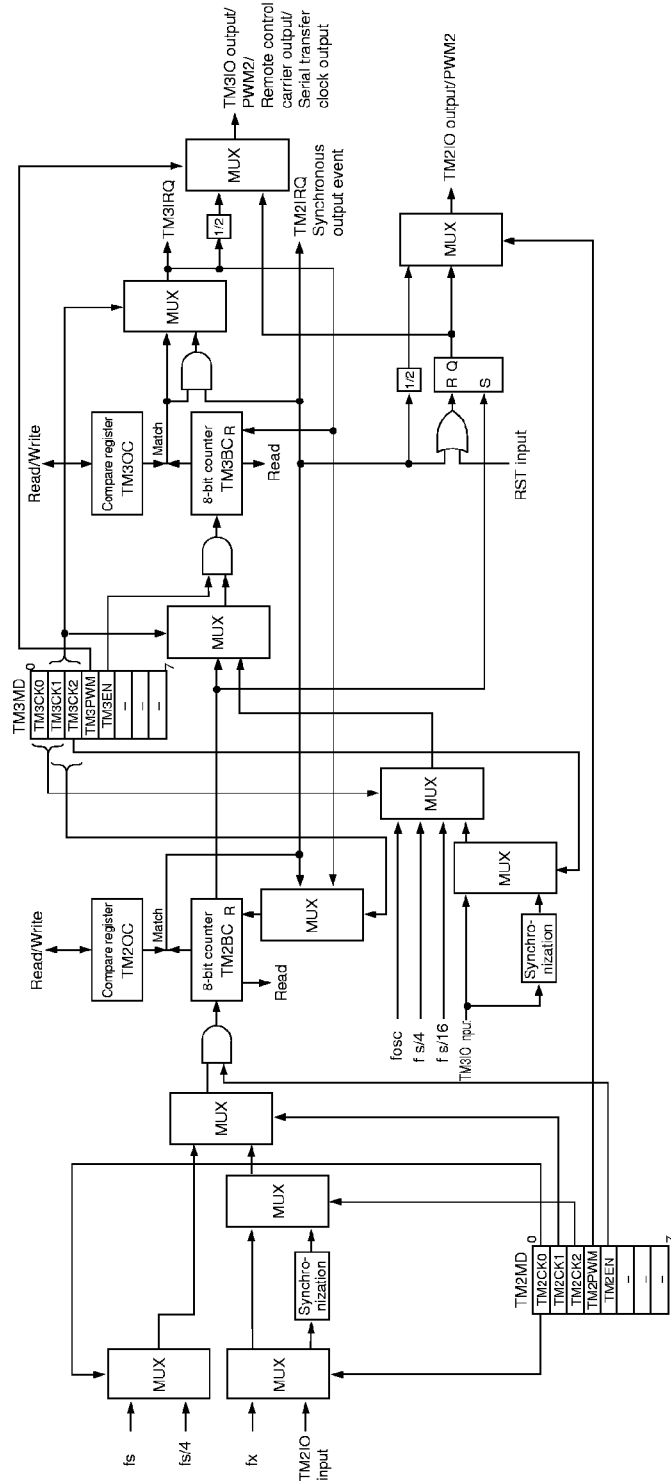

Figure 4-1-2 Timers 2, 3 Block Diagram

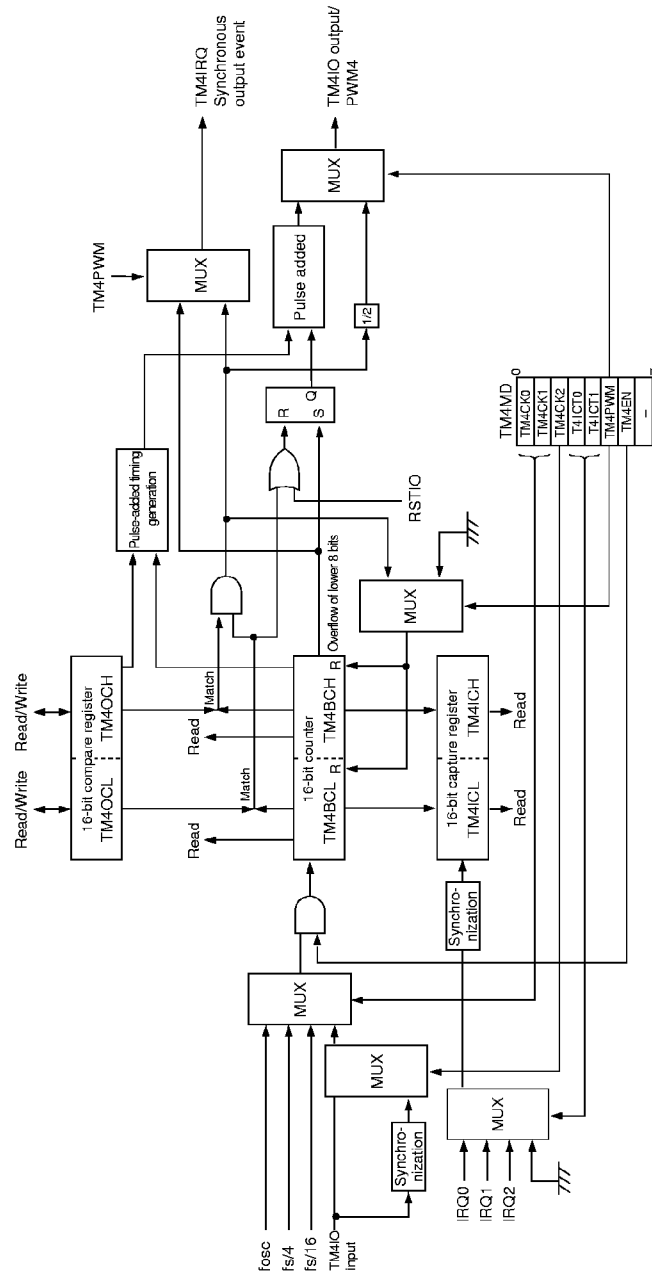

Figure 4-1-3 Timer 4 Block Diagram

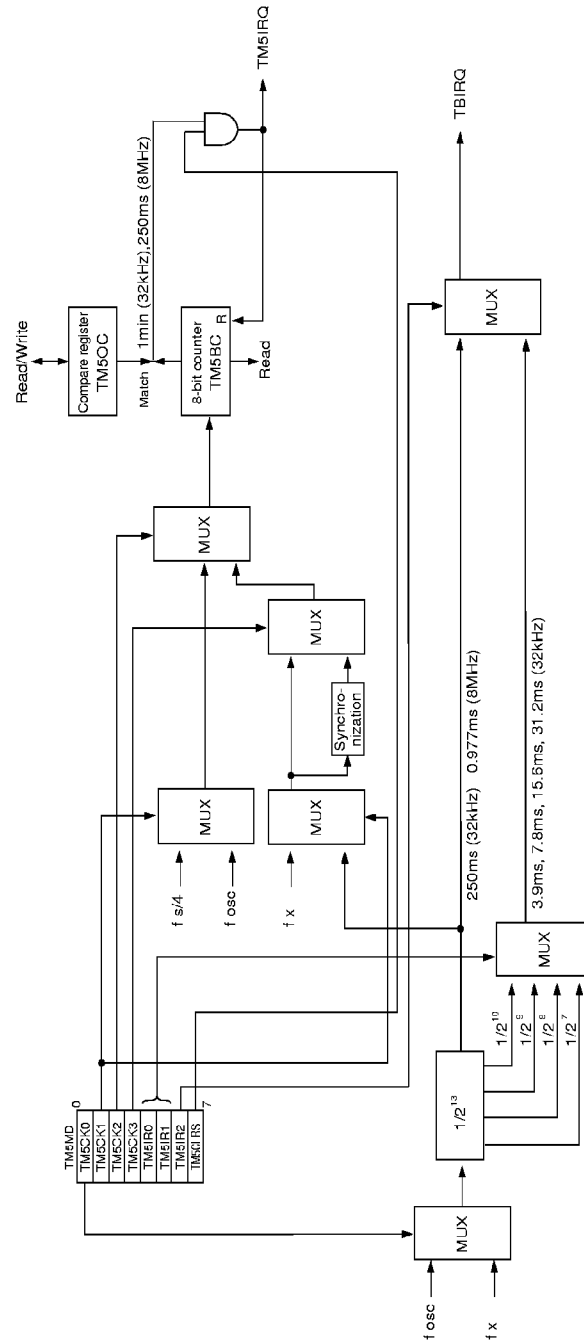

Figure 4-1-4 Timer 5/Time Base Block Diagram

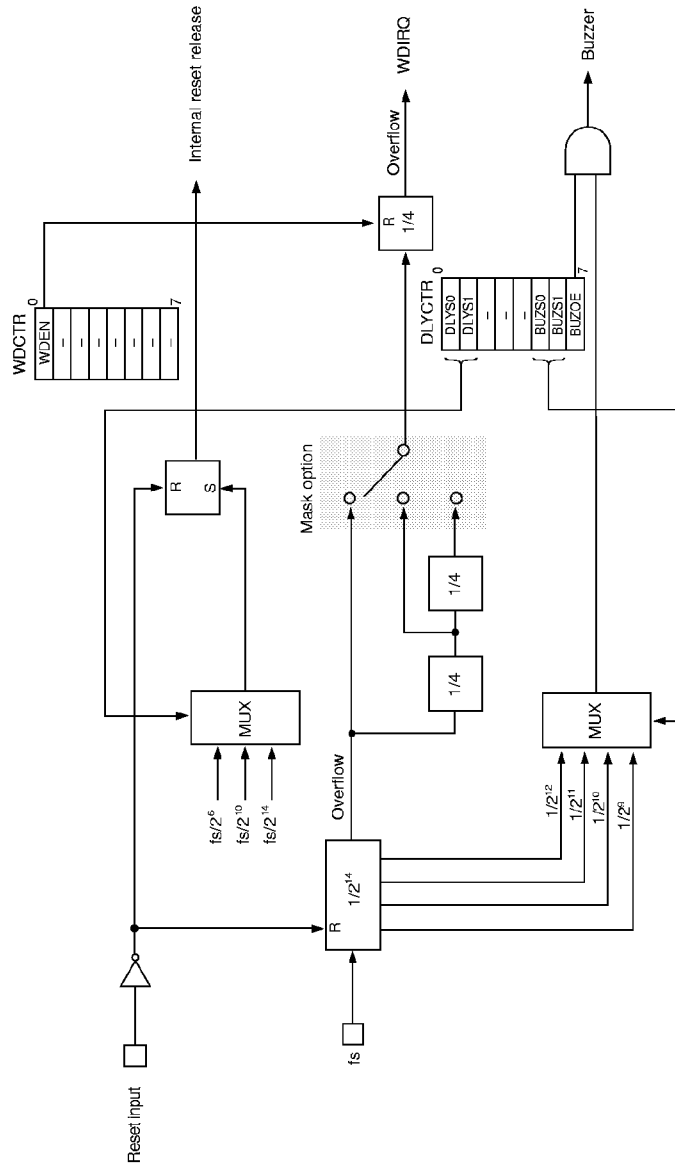

Figure 4-1-5 Watchdog Timer, Buzzer Block Diagram

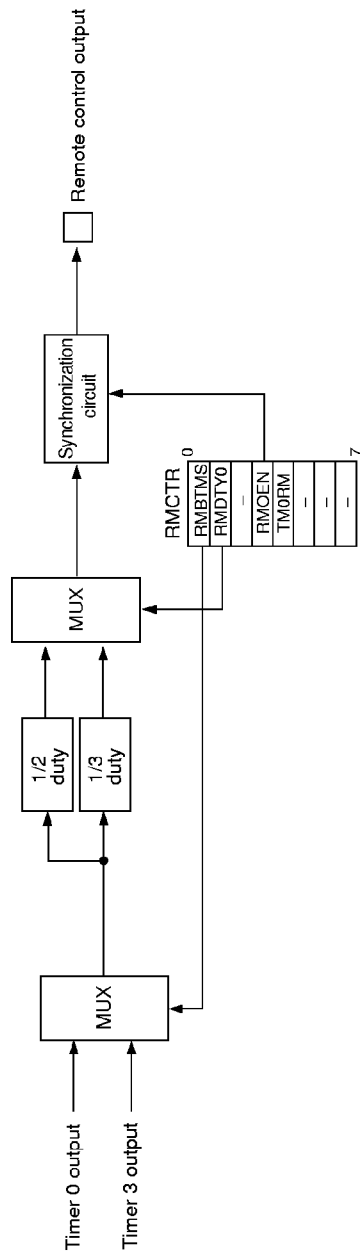

Figure 4-1-6 Remote Control Transmission Block Diagram

4-2 8-bit Timer Operation (timers 0, 1)

4-2-1 Overview

Functions for timers 0 and 1 are listed below.

Table 4-2-1 Summary of 8-bit Timer Functions

	Timer 0 (8-bit)	Timer 1 (8-bit)
Interrupt	TM0IRQ	TM1IRQ
Timer operation	✓	✓
Event counter	✓	✓
Timer pulse output	✓	✓
Serial transmission clock	✓ (SIF2)	—
Synchronous output timing generation	—	✓
PWM output	✓	—
Cascade connection	✓	
Remote control carrier pulse generation	✓	—

4-2-2 Operation

■ Timer Operation (timers 0, 1)

When servicing an interrupt, reset the timer 0 interrupt request flag before starting timer 0.

During a count operation, be careful if the value set in TM0OC is smaller than the value of binary counter 0, since the count-up operation will continue until overflow occurs.

Settings for timer operation are listed below. Timer 0 is used as an example.

- (1) Set the TM0EN flag of the timer 0 mode register (TM0MD) to "0" to stop the count operation of timer 0.
- (2) Set the TM0CK2~0 flags of the TM0MD register to select fosc, fs, or fs/4 as the clock source.
- (3) Set the TM0PWM flag of the TM0MD register to "0" so that normal timer operation is selected.
- (4) Set a value in compare register 0 (TM0OC).
- (5) Set the TM0EN flag of the TM0MD register to "1" to start the timer.
- (6) When timer 0 begins operation, binary counter 0 (TM0BC) will count upward from X'00'.
- (7) When the value of binary counter 0 matches that of the TM0OC register, the timer 0 interrupt request flag is set, and the binary counter is reset to X'00' and begins to count upward again.

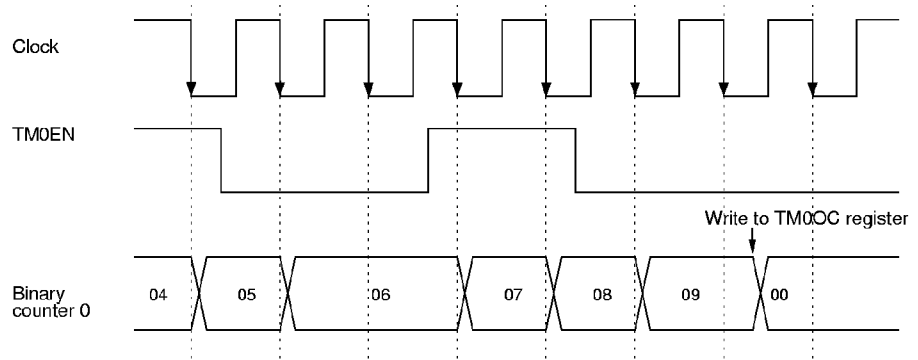

Figure 4-2-1 Binary Counter 0 (TM0BC) Count Timing



If the TM0EN flag of TM0MD register is changed simultaneously with other bits, the switching operation may cause binary counter 0 to be incremented.



If the value of TM0OC register is overwritten while timer 0 has stopped counting, binary counter 0 will be reset to X'00'.

■ Event Count Function (timers 0, 1)

Settings for the event count function are listed below. Timer 0 is used as an example.

- (1) Set the TMOEN flag of the timer 0 mode register (TM0MD) to "0" to stop the count operation of timer 0.
- (2) Use the TM0CK2~0 flags of the TM0MD register to select TM0IO input or synchronous TM0IO input as the clock source.
- (3) Set the TM0PWM flag of the TM0MD register to "0" so that normal timer operation is selected.
- (4) Set a value in compare register 0 (TM0OC).
- (5) Set the TMOEN flag of the TM0MD register to "1" to start the timer.
- (6) When timer 0 begins operation, binary counter 0 will count upward from X'00'.
- (7) When the value of binary counter 0 matches that of the TM0OC register, the timer 0 interrupt request flag is set, and the binary counter 0 is reset to X'00' and begins to count upward again.

If TM0IO input is selected as the clock source and the value of binary counter 0 is to be read during operation, select synchronous TM0IO input to avoid reading data that may be incomplete during count-up transitions. However, with synchronous TM0IO input, it is not possible to return from STOP/HALT modes.

When synchronous TM0IO is selected, the timer 0 clock source is synchronized with the system clock after a transition of the TM0IO input signal. Binary counter 0 counts upward based on a signal synchronized to the system clock. Therefore, correct values can be read from binary counter 0.

Figure 4-2-2 Timer 0 Event Counter Timing (when synchronous TM0IO

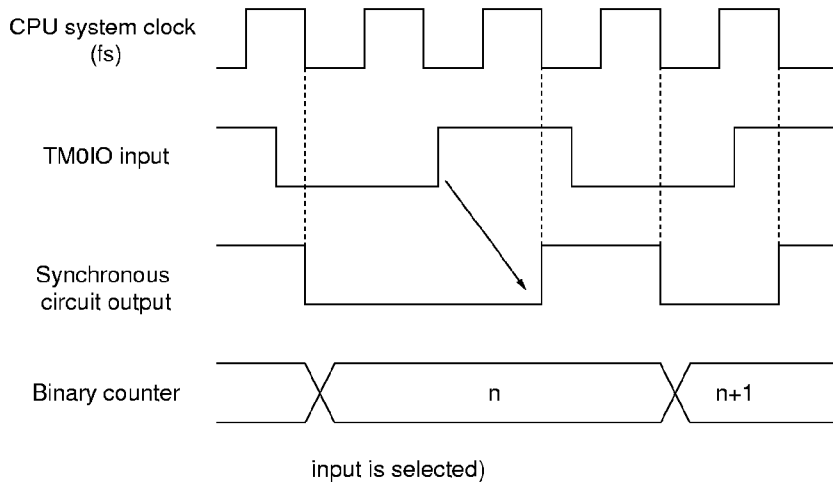

The period of a signal output to the port is 1/2 of the period set in the TM0OC register.

If port 1 is to be used as a pulse output pin, it is necessary to set the port 1 output direction control register (P1DIR) and the port 1 pull-up/pull-down resistor control register (P1PLU).

■ Timer Pulse Output Function (timers 0, 1)

Settings for the timer pulse output function are listed below. Timer 0 is used as an example.

- (1) Set the 'TM0EN flag of the timer 0 mode register (TM0MD) to "0" to stop the count operation of timer 0.
- (2) Set bit 0 of the port 1 output/input mode register (P1OMD) to "1" to set the special function pin. Bit 0 of port 1 will be the pulse output pin.
- (3) Set the TM0CK2~0 flags of the TM0MD register to select fosc, fs, or fs/4 as the clock source.
- (4) Set the TM0PWM flag of the TM0MD register to "0" so that normal timer operation is selected.
- (5) Set a value in compare register 0 (TM0OC).
- (6) Set the 'TM0EN flag of the TM0MD register to "1" to start the timer.
- (7) When timer 0 begins operation, binary counter 0 will count upward from X'00'.
- (8) When the value of binary counter 0 matches that of the TM0OC register, the timer 0 interrupt request flag is set, and the binary counter 0 is reset to X'00' and begins to count upward again.

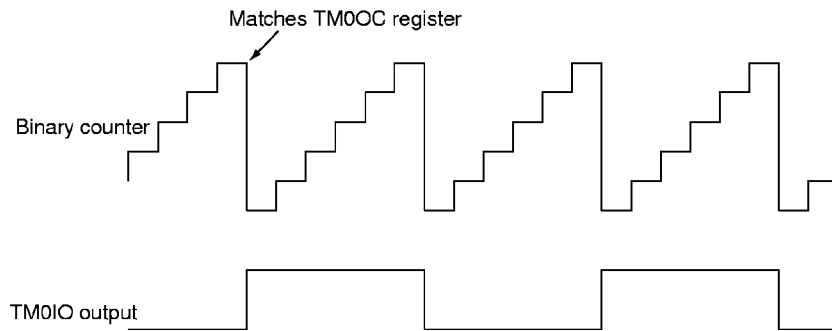

Figure 4-2-3 Timer Pulse Output Timing

■ Synchronous Output Timing Generation Function (timer 1)

Settings for the synchronous output timing generation function are listed below.

- (1) Set the TM1EN flag of the timer 1 mode register (TM1MD) to "0" so that the count operation of timer 1 is stopped.
- (2) Set the P7SYEVS2 and P7SYEVS1 flags of pin control register 2 (FLOAT2) to select timer 1 interrupts.
- (3) Set the synchronous output control register (SYSMD) to configure port 7 bits for use as synchronous output pins.
- (4) Set the TM1CK2~0 flags of the TM1MD register to select fs/16, fs/64, fx or synchronous fx as the clock source.
- (5) Set the TM1PWM flag of the TM1MD register to "0" so that normal timer operation is selected.
- (6) Set a value in compare register 1 (TM1OC).
- (7) Set the TM1EN flag of the TM1MD register to "1" to start the timer.
- (8) When timer 1 begins operation, binary counter 1 will count upward from X'00'.
- (9) When the value of binary counter 1 matches that of the TM1OC register, the timer 1 interrupt request flag is set, binary counter 1 is reset to X'00' and begins to count upward again.
- (10) At the timing when the value of binary counter 1 matches that of the TM1OC register, the values at port 7 synchronous output pins will change.

If the *TM1PWM* flag of the *TM1MD* register is set to "1" and timer 0 PWM output is selected, the PWM output of timer 0 will also be output from the *TM1IO* pin.

If port 1 is to be used as a PWM output pin, the *P1DIR* and *P1PLU* registers must be set.

■ PWM Output Function (Timer 0)

Settings for the PWM output function are listed below.

- (1) Set the *TM0EN* flag of the timer 0 mode register (*TM0MD*) to "0" to stop the count operation of timer 0.
- (2) Set bit 0 of the port 1 output/input mode register (*PIOMD*) to the special function pin setting. Bit 0 of port 1 will be the PWM output pin.
- (3) Set the *TM0CK2~0* flags of the *TM0MD* register to select *fosc*, *fs*, or *fs/4* as the clock source. The period of the output waveform is determined based on the clock source.
- (4) Set the *TM0PWM* flag of the *TM0MD* register to "1" so that PWM operation is selected.
- (5) Set a value in compare register 0 (*TM0OC*). The high interval of the output waveform is determined based on the value of the *TM0OC* compare register.
- (6) Set the *TM0EN* flag of the *TM0MD* register to "1" to start the timer.
- (7) When timer 0 begins operation, binary counter 0 will count upward from X'00'.
- (8) A high-level signal is output from the port beginning when binary counter 0 starts counting at X'00' and ending when the value of binary counter 0 matches the value set in the *TM0OC* register.
- (9) When the value of binary counter 0 matches that of the *TM0OC* register, a low-level signal is output from the port.
- (10) Binary counter 0 continues to count upward until X'FF' is reached. At the next count-up cycle, the value of binary counter 0 is reset to X'00', a high-level signal is output from the port, and counting begins again.

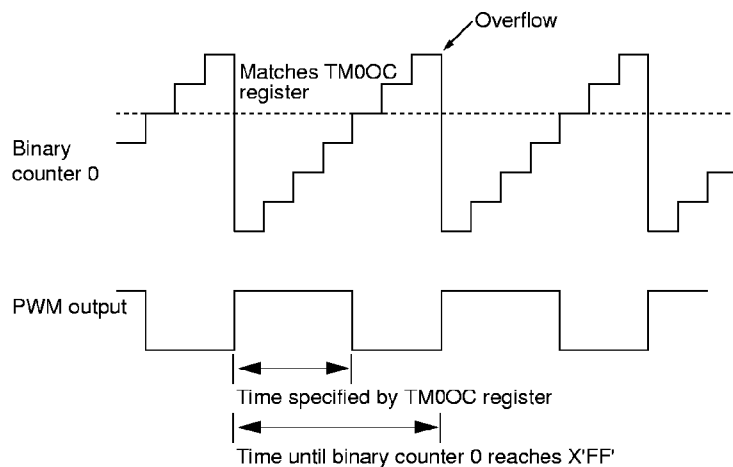

Figure 4-2-4 PWM Output Timing

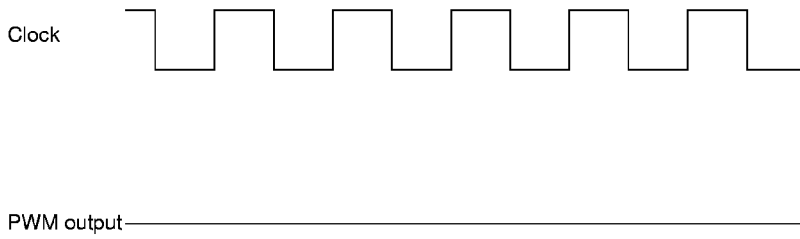

Figure 4-2-5 PWM Output Timing (when TM0OC register is X'00')

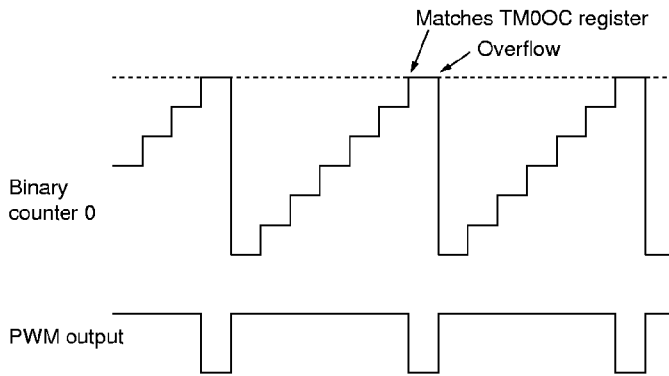

Figure 4-2-6 PWM Output Timing (when TM0OC register is X'FF')

The serial interface clock source has a frequency that is 1/2 of the overflow output of timer 0.

See chapter 5 for serial interface settings, refer to the chapter on serial functions.

■ Serial Transfer Clock Function (timer 0)

Settings for the serial transfer clock function are listed below.

- (1) Set the TM0EN flag of the timer 0 mode register (TM0MD) to "0" to stop the count operation of timer 0.
- (2) Set the SC2CK1 and SC2CK0 flags of the serial interface 2 mode register 1 (SC2MD1) to select 1/2 of the timer 0 overflow frequency as the clock source.
- (3) Set the TM0CK2~0 flags of the TM0MD register to select fosc, fs, or fs/4 as the clock source.
- (4) Set the TM0PWM flag of the TM0MD register to "0" to select normal timer operation.
- (5) Set a value in compare register 0 (TM0OC).
- (6) Set the TM0EN flag of the TM0MD register to "1" to start the timer.
- (7) When timer 0 begins operation, binary counter 0 counts upward from X'00'.
- (8) When the value of binary counter 0 matches that of the TM0OC register, the timer 0 interrupt request flag is set, the value of binary counter 0 is reset to X'00', and counting begins again.

■ Cascade Connection Function (timer 0 + timer 1)

Settings for the cascade connection function are listed below. Timer 0 and timer 1 are connected to operate as a 16-bit timer. Output from the timer is also possible.

- (1) Set the TM0EN flag of the timer 0 mode register (TM0MD) to "0" to stop the count operation of timer 0.
- (2) Set the TM1EN flag of the timer 1 mode register (TM1MD) to "0" to stop the count operation of timer 1.
- (3) Set the TM0CK2~0 flags of the TM0MD register to select fosc, fs, or fs/4 as the clock source.
- (4) Use the TM1CK2~0 flags of the TM1MD register to set the clock source as a cascaded connection with timer 0.
- (5) Set the TM0PWM flag of the TM0MD register to "0" to select normal timer operation.
- (6) Set values in compare register 0 (TM0OC) and compare register 1 (TM1OC).
- (7) Set the TM0EN flag of the TM0MD register to "1" to start the timer 0.
- (8) Set the TM1EN flag of the TM1MD register to "1" to start the timer 1.
- (9) When timers 0 and 1 begin operation, the binary counters begin counting upward from X'0000' as a 16-bit counter.
- (10) When the value of the 16-bit binary counter matches that of the 16-bit compare register (TM0OC+TM1OC), the timer 1 interrupt request flag is set, the value of the 16-bit binary counter is reset to X'0000', and counting begins again.

Disable the timer 0 interrupt.



Use a 16-bit access instruction to set the (TM1OC+TM0OC) register.

4-3 8-bit Timer Operation (timers 2, 3)

4-3-1 Overview

Functions for timers 2 and 3 are listed below.

Table 4-3-1 Summary of 8-bit Timer Functions

	Timer 2 (8-bit)	Timer 3 (8-bit)
Interrupt	TM2IRQ	TM3IRQ
Timer operation	✓	✓
Event counter	✓	✓
Timer pulse output	✓	✓
Serial transmission clock	—	✓ (SIF0,1)
Synchronous output timing generation	✓	—
PWM output	✓	—
Cascade connection	✓	
Remote control carrier pulse generation	—	✓

When servicing an interrupt, reset the timer 2 interrupt request flag before starting timer 2.

During a count operation, be careful if the value set in TM2OC is smaller than the value of binary counter 2, since the count-up operation will continue until overflow occurs.

If fx is to be selected as the clock source and the value of binary counter 2 is to be read during operation, select synchronized fx in order to avoid reading data that may be incomplete during count-up transitions. However, with synchronized fx, it is not possible to return from STOP/HALT modes.

4-3-2 Operation

■ Timer Operation (timers 2, 3)

Settings for timer operation are listed below. Timer 2 is used as an example.

- (1) Set the TM2EN flag of the timer 2 mode register (TM2MD) to "0" to stop the count operation of timer 2.
- (2) Set the TM2CK2~0 flags of the TM2MD register to select fs, fs/4, fx, or synchronized fx as the clock source.
- (3) Set the TM2PWM flag of the TM2MD register to "0" so that normal timer operation is selected.
- (4) Set a value in compare register 2 (TM2OC).
- (5) Set the TM2EN flag of the TM2MD register to "1" to start the timer.
- (6) When timer 2 begins operation, binary counter 2 (TM2BC) will count upward from X'00'.
- (7) When the value of binary counter 2 matches that of the TM2OC register, the timer 2 interrupt request flag is set, and the binary counter 2 is reset to X'00' and begins to count upward again.

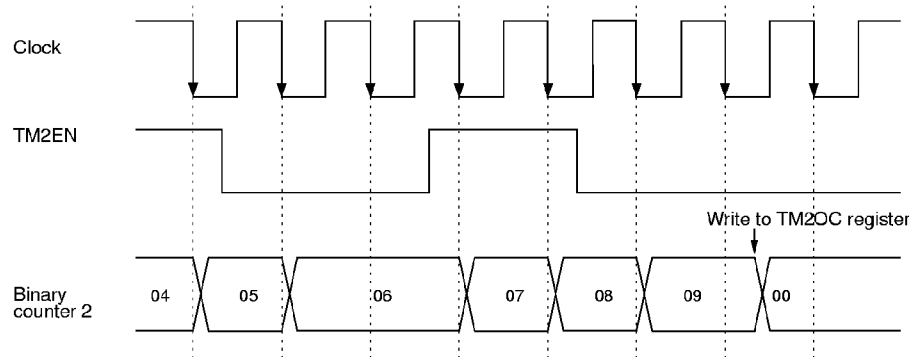

Figure 4-3-1 Binary Counter 2 (TM2BC) Count Timing



If the TM2EN flag of TM2MD register is changed simultaneously with other bits, the switching operation may cause binary counter 2 to be incremented.



If the value of TM2OC register is overwritten while timer 2 has stopped counting, binary counter 2 will be reset to X'00'.

■ Event Count Function (timers 2, 3)

Settings for the event count function are listed below. Timer 2 is used as an example.

- (1) Set the TM2EN flag of the timer 2 mode register (TM2MD) to "0" to stop the count operation of timer 2.
- (2) Use the TM2CK2-0 flags of the TM2MD register to select TM2IO input or synchronous TM2IO input as the clock source.
- (3) Set the TM2PWM flag of the TM2MD register to "0" so that normal timer operation is selected.
- (4) Set a value in compare register 2 (TM2OC).
- (5) Set the TM2EN flag of the TM2MD register to "1" to start the timer.
- (6) When timer 2 begins operation, binary counter 2 will count upward from X'00'.
- (7) When the value of binary counter 2 matches that of the TM2OC register, the timer 2 interrupt request flag is set, and the binary counter 2 is reset to X'00' and begins to count upward again.

If TM2IO input is selected as the clock source and the value of binary counter 2 is to be read during operation, select synchronized TM2IO input to avoid reading data that may be incomplete during count-up transitions. However, with synchronized TM2IO input, it is not possible to return from STOP/HALT modes.

When synchronized TM2IO is selected, the timer 2 clock source is synchronized with the system clock after a transition of the TM2IO input signal. Binary counter 2 counts upward based on a signal synchronized to the system clock. Therefore, correct values can be read from binary counter 2.

Figure 4-2-2 Timer 2 Event Counter Timing (when synchronous TM2IO

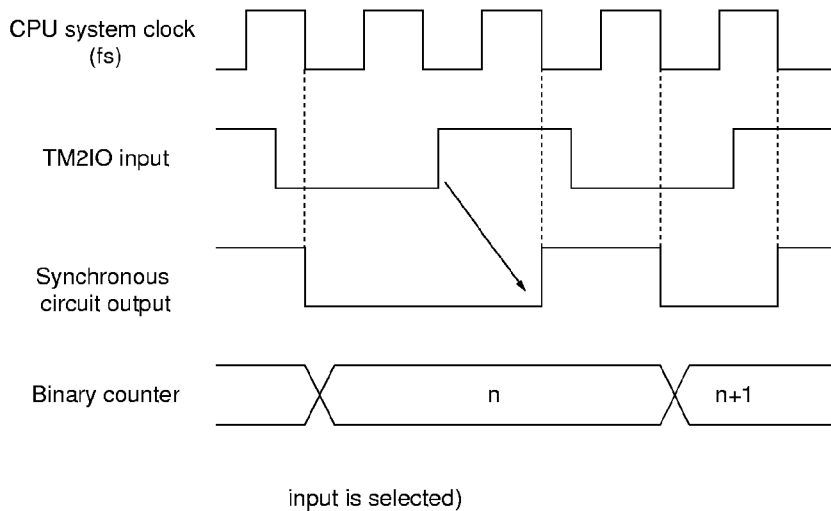

The period of a signal output to the port is 1/2 of the period set in the TM2OC register.

If port 1 is to be used as a pulse output pin, it is necessary to set the port 1 output direction control register (P1DIR) and the port 1 pull-up/pull-down resistor control register (P1PLU).

■ Timer Pulse Output Function (timers 2, 3)

Settings for the timer pulse output function are listed below. Timer 2 is used as an example.

- (1) Set the TM2EN flag of the timer 2 mode register (TM2MD) to "0" to stop the count operation of timer 2.
- (2) Set bit 2 of the port 1 output/input mode register (P1OMD) to "1" to set the special function pin. Bit 2 of port 1 will be specified as the pulse output pin.
- (3) Set the TM2CK2~0 flags of the TM2MD register to select fs, fs/4, fx, or synchronized fx as the clock source.
- (4) Set the TM2PWM flag of the TM2MD register to "0" so that normal timer operation is selected.
- (5) Set a value in compare register 2 (TM2OC).
- (6) Set the TM2EN flag of the TM2MD register to "1" to start the timer.
- (7) When timer 2 begins operation, binary counter 2 will count upward from X'00'.
- (8) When the value of binary counter 2 matches that of the TM2OC register, the timer 2 interrupt request flag is set, and the binary counter 2 is reset to X'00' and begins to count upward again.

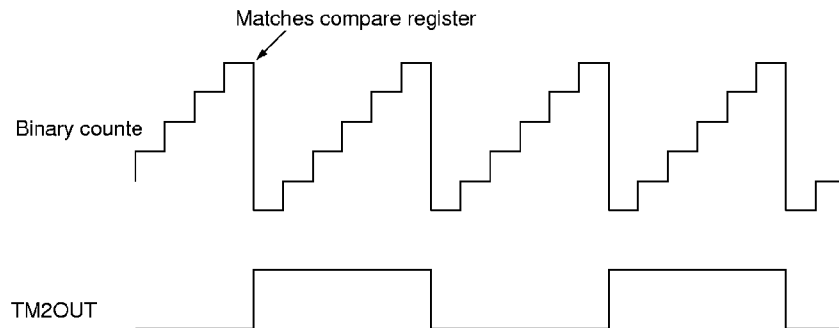

Figure 4-3-3 Timer Pulse Output Timing

■ Synchronous Output Timing Generation Function (timer 2)

Settings for the synchronous output timing generation function are listed below.

- (1) Set the TM2EN flag of the timer 2 mode register (TM2MD) to "0" so that the count operation of timer 2 is stopped.
- (2) Set the P7SYEVS2 and P7SYEVS1 flags of pin control register 2 (FLOAT2) to select timer 2 interrupts.
- (3) Set the synchronous output control register (SYSMD) to configure port 7 bits for use as synchronous output pins.
- (4) Set the TM2CK2~0 flags of the TM2MD register to select fs, fs/4, fx or synchronous fx as the clock source.
- (5) Set the TM2PWM flag of the TM2MD register to "0" so that normal timer operation is selected.
- (6) Set a value in compare register 2 (TM2OC).
- (7) Set the TM2EN flag of the TM2MD register to "1" to start the timer.
- (8) When timer 2 begins operation, binary counter 2 will count upward from X'00'.
- (9) When the value of binary counter 2 matches that of the TM2OC register, the timer 2 interrupt request flag is set, binary counter 2 is reset to X'00' and begins to count upward again.
- (10) At the timing when the value of binary counter 2 matches that of the TM2OC register, the values at port 7 synchronous output pins will change.

If port 7 pins are to be used as pulse output pins, it is necessary to set the P7DIR register and the P7PLUD register.

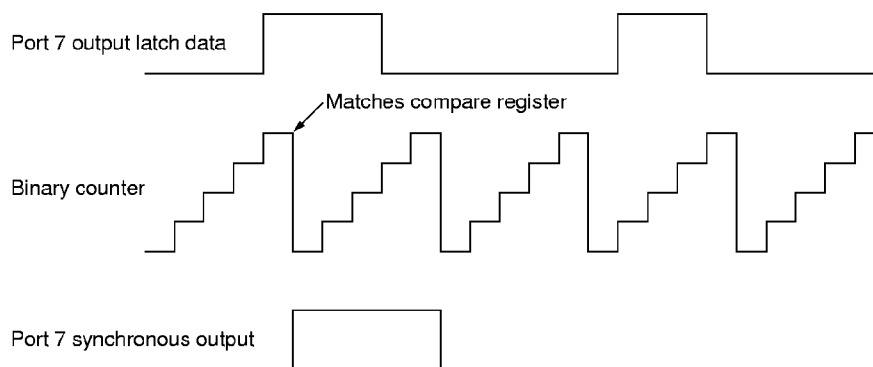

Figure 4-3-4 Port 7 Synchronous Output Timing

If the TM3PWM flag of the TM3MD register is set to "1" and timer 2 PWM output is selected, the PWM output of timer 2 will also be output from the TM3IO pin.

If port 1 is to be used as a PWM output pin, the P1DIR and P1PLU registers must be set.

■ PWM Output Function (Timer 2)

Settings for the PWM output function are listed below.

- (1) Set the TM2EN flag of the timer 2 mode register (TM2MD) to "0" to stop the count operation of timer 0.
- (2) Set bit 2 of the port 1 output/input mode register (P1OMD) to the special function pin setting. Bit 2 of port 1 will be specified as the PWM output pin.
- (3) Set the TM2CK2~0 flags of the TM2MD register to select fs, fs/4, fx, or synchronous fx as the clock source. The period of the output waveform is determined based on the clock source.
- (4) Set the TM2PWM flag of the TM2MD register to "1" so that PWM operation is selected.
- (5) Set a value in compare register 2 (TM2OC). The high interval of the output waveform is determined based on the value of the TM2OC compare register.
- (6) Set the TM2EN flag of the TM2MD register to "1" to start the timer.
- (7) When timer 2 begins operation, binary counter 2 will count upward from X'00'.
- (8) A high-level signal is output from the port beginning when binary counter 2 starts counting at X'00' and ending when the value of binary counter 2 matches the value set in the TM2OC register.
- (9) When the value of binary counter 2 matches that of the TM2OC register, a low-level signal is output from the port.
- (10) Binary counter 2 continues to count upward until X'FF' is reached. At the next count-up cycle, the value of binary counter 2 is reset to X'00', a high-level signal is output from the port, and counting begins again.

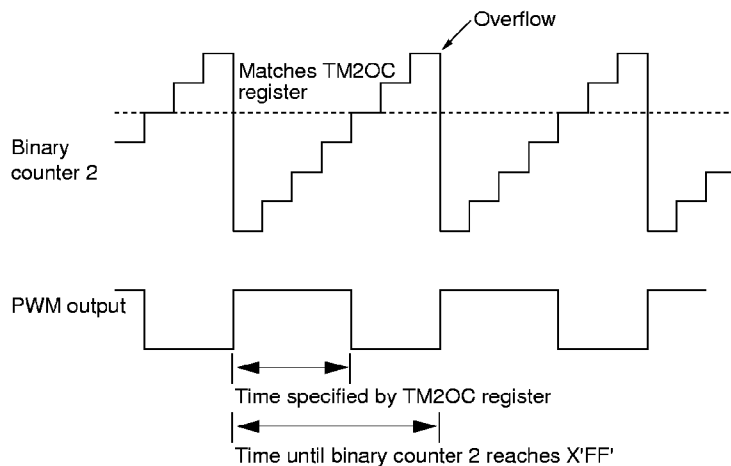

Figure 4-3-5 PWM Output Timing

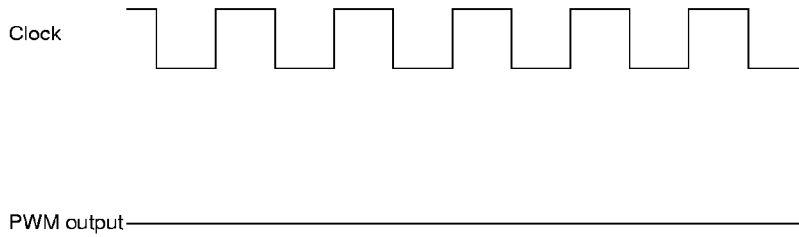

Figure 4-3-6 PWM Output Timing (when TM2OC register is X'00')

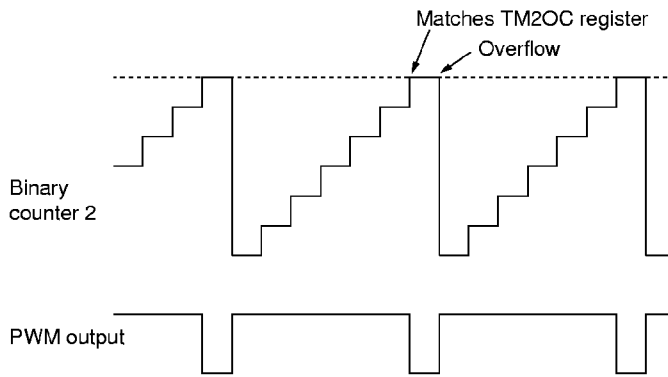

Figure 4-3-7 PWM Output Timing (when TM2OC register is X'FF')

The clock source for the serial interface has a frequency that is 1/2 of the overflow output of timer 3.

For serial interface settings, refer to the chapter on serial functions.

■ Serial Transfer Clock Function (timer 3)

Settings for the serial transfer clock function are listed below.

- (1) Set the TM3EN flag of the timer 3 mode register (TM3MD) to "0" to stop the count operation of timer 3.
- (2) Set the SC0CK1 and SC0CK0 flags of the serial interface 0 mode register 1 (SC0MD1) to select 1/2 of the timer 3 overflow frequency as the clock source.
- (3) Set the TM3CK2~0 flags of the TM3MD register to select fosc, fs, fs/4, or fs/16 as the clock source.
- (4) Set the TM3PWM flag of the TM3MD register to "0" to select timer 3 output.
- (5) Set a value in compare register 3 (TM3OC).
- (6) Set the TM3EN flag of the TM3MD register to "1" to start the timer.
- (7) When timer 3 begins operation, binary counter 3 counts upward from X'00'.
- (8) When the value of binary counter 3 matches that of the TM3OC register, the timer 3 interrupt request flag is set, the value of binary counter 3 is reset to X'00', and counting begins again.

■ Cascade Connection Function (timer 2 + timer 3)

Settings for the cascade connection function are listed below. Timer 2 and timer 3 are connected to operate as a 16-bit timer.

- (1) Set the TM2EN flag of the timer 2 mode register (TM2MD) to "0" to stop the count operation of timer 2.
- (2) Set the TM3EN flag of the timer 3 mode register (TM3MD) to "0" to stop the count operation of timer 3.
- (3) Set the TM2CK2~0 flags of the TM2MD register to select fs, fs/4, fx, or synchronized fx as the clock source.
- (4) Use the TM3CK2~0 flags of the TM3MD register to set the clock source as a cascade connection with timer 2.
- (5) Set the TM2PWM flag of the TM2MD register to "0" to select normal timer operation.
- (6) Set values in compare register 2 (TM2OC) and compare register 3 (TM3OC).
- (7) Set the TM2EN flag of the TM2MD register to "1" to start the timer.
- (8) Set the TM3EN flag of the TM3MD register to "1" to start the timer.
- (9) When timers 2 and 3 begin operation, the binary counters begin counting upward from X'0000' as a 16-bit counter.
- (10) When the value of the 16-bit binary counter matches that of the 16-bit register (TM3OC+TM2OC), the timer 3 interrupt request flag is set, the value of the 16-bit binary counter is reset to X'0000', and counting begins again.

Disable the timer 2 interrupt.



Use a 16-bit access instruction to set the (TM3OC+TM2OC) register.

4-4 16-bit Timer Operation (timer 4)

4-4-1 Overview

Timer 4 is a 16-bit programmable counter that can be used as an event counter. A signal with a frequency of 1/2 of the timer 4 overflow signal can be output from the TM4IO pin. An input capture function and pulse added type PWM output function can also be used.

4-4-2 Operation

■ Timer Operation

Settings for timer operation are listed below.

- (1) Set the TM4EN flag of the timer 4 mode register (TM4MD) to "0" to stop the count operation of timer 4.
- (2) Set the TM4CK2~0 flags of the TM4MD register to select fosc, fs/4, or fs/16 as the clock source.
- (3) Set the TM4PWM flag of the TM4MD register to "0" to select 16-bit timer operation.
- (4) Set a value in compare register 4 (TM4OCH, TM4OCL).
- (5) Set the TM4EN flag of the TM4MD register to "1" to start the timer.
- (6) When timer 4 begins operation, binary counter 4 counts upward from X'0000'.
- (7) When the value of binary counter 4 matches that of the TM4OCH and TM4OCL registers, the timer 4 interrupt request flag is set, the value of binary counter 4 is reset to X'0000', and counting begins again.

When servicing an interrupt, reset the timer 4 interrupt request flag before operating timer 4.

During a count operation, be careful if the value set in TM4OCH and TM4OCL is smaller than the value of binary counter 4, since the count-up operation will continue until overflow occurs.

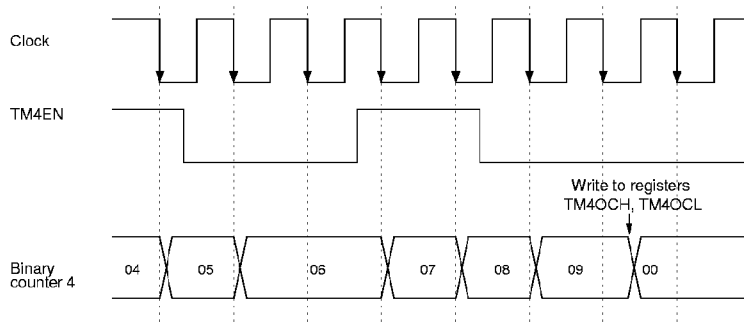



Figure 4-4-1 Binary Counter 4 (TM4BC) Count Timing

-  If the TM4EN flag of the TM4MD register is changed simultaneously with other bits, the switching operation may cause binary counter 4 to be incremented.
-  If the value of the TM4OCH, TM4OCL register is overwritten while timer 4 has stopped counting, binary counter 4 will be reset to X'0000'.

■ Event Count Function

Settings for the event count function are listed below.

- (1) Set the TM4EN flag of the timer 4 mode register (TM4MD) to "0" to stop the count operation of timer 4.
- (2) Use the TM4CK2~0 flags of the TM4MD register to select TM4IO input or synchronized TM4IO input as the clock source.
- (3) Set the TM4PWM flag of the TM4MD register to "0" so that 16-bit timer operation is selected.
- (4) Set a value in compare register 4 (TM4OCH, TM4OCL).
- (5) Set the TM4EN flag of the TM4MD register to "1" to start the timer.
- (6) When timer 4 begins operation, binary counter 4 will count upward from X'0000'.
- (7) When the value of binary counter 4 matches that of the TM4OCH and TM4OCL registers, the timer 4 interrupt request flag is set, and the binary counter is reset to X'0000' and begins to count upward again.

If TM4IO input is selected as the clock source and the value of binary counter 4 is to be read during operation, select synchronized TM4IO input to avoid reading data that may be incomplete during count-up transitions. However, with synchronized TM4IO input, it is not possible to return from STOP/HALT modes.

When synchronized TM4IO is selected, the timer 4 clock source is synchronized with the system clock after a transition of the TM4IO input signal. Binary counter 4 counts upward based on a signal synchronized to the system clock. Therefore, correct values can be read from binary counter 4.

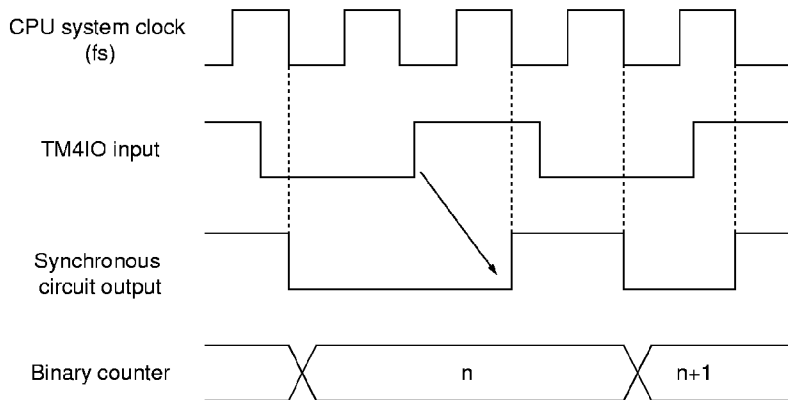

Figure 4-4-2 Timer 4 Event Counter Timing (when synchronous TM4IO input is selected)

The period of the output signal from the port is 1/2 of the period set in the TM4OCH, TM4OCL register.

■ Timer Pulse Output Function

Settings for the timer pulse output function are listed below.

- (1) Set the TM4EN flag of the timer 4 mode register (TM4MD) to "0" so that the count operation of timer 4 is stopped.
- (2) Set bit 4 of the port 1 output/input mode register (P1OMD) to the special function pin setting. Bit 4 of port 1 will be specified as the pulse output pin.
- (3) Use the TM4CK2~0 flags of the TM4MD register to select fosc, fs/4, or fs/16 as the clock source.
- (4) Set the TM4PWM flag of the TM4MD register to "0" so that 16-bit timer operation is selected.
- (5) Set a value in compare register 4 (TM4OCIL, TM4OCL).
- (6) Set the TM4EN flag of the TM4MD register to "1" to start the timer.
- (7) When timer 4 begins operation, binary counter 4 will count upward from X'0000'.
- (8) When the value of binary counter 4 matches that of the TM4OCH and TM4OCL registers, the timer 4 interrupt request flag is set, and the binary counter is reset to X'0000' and begins to count upward again.

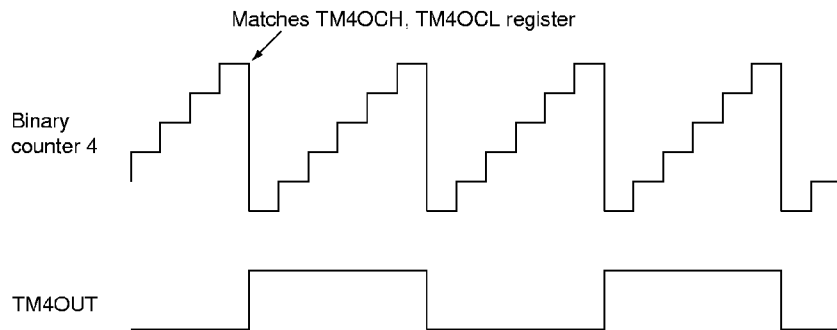

Figure 4-4-3 Timer Pulse Output Timing

■ Synchronous Output Timing Generation Function

Settings for the synchronous output timing generation function are listed below.

- (1) Set the TM4EN flag of the timer 4 mode register (TM4MD) to "0" so that the count operation of timer 4 is stopped.
- (2) Set the P7SYEVS2 and P7SYEVS1 flags of pin control register 2 (FLOAT2) to select timer 4 interrupts.
- (3) Set the synchronous output control register (SYSMD) to configure port 7 bits for use as synchronous output pins.
- (4) Set the TM4CK2~0 flags of the TM4MD register to select f_{osc} , $f_s/4$, or $f_s/16$ as the clock source.
- (5) Set the TM4PWM flag of the TM4MD register to "0" so that 16-bit timer operation is selected.
- (6) Set a value in compare register 4 (TM4OCH, TM4OCL).
- (7) Set the TM4EN flag of the TM4MD register to "1" to start the timer.
- (8) When timer 4 begins operation, binary counter 4 will count upward from X'0000'.
- (9) When the value of binary counter 4 matches that of the TM4OCH and TM4OCL registers, the timer 4 interrupt request flag is set, binary counter 4 is reset to X'0000' and begins to count upward again.
- (10) At the timing when the value of binary counter 4 matches that of the TM4OCH and TM4OCL registers, the values at port 7 synchronous output pins will change.

If port 7 pins are to be used as pulse output pins, it is necessary to set the P7DIR register.

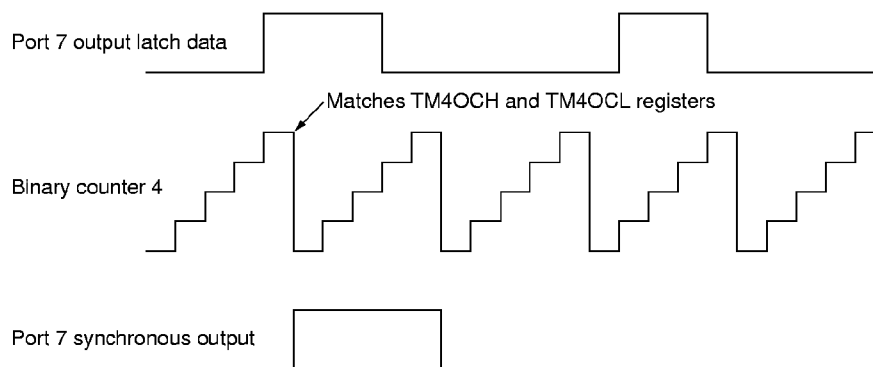



Figure 4-4-4 Port 7 Synchronous Output Timing

If bit 4 of port 1 is to be used as a PWM output pin, set the P1DIR and P1PLU registers.

■ Pulse Added Type PWM Output Function

In the pulse added method, a 1-bit output is appended to the basic component of the 8-bit PWM output. Precise control is possible based on the number of PWM repetitions (256 times) to which this bit is appended. Settings for the pulse added type PWM output function are listed below.

- (1) Set the TM4EN flag of the timer 4 mode register (TM4MD) to "0" to stop the count operation of timer 4.
- (2) Set bit 4 of the port 1 output/input mode register (P1OMD) to the special function pin setting. Bit 4 of port 1 will be specified as the PWM output pin.
- (3) Use the TM4CK2~0 flags of the TM4MD register to select fosc, fs/4, or fs/16 as the clock source. The period of the output waveform is determined based on the clock source.
- (4) Set the TM4PWM flag of the TM4MD register to "1" so that PWM operation is selected.
- (5) Set a value in the lower 8 bits of compare register 4 (TM4OCL). The high interval of the output waveform is determined based on the value of the lower 8 bits of compare register 4 (TM4OCL).
- (6) Set the position of the added pulse in the upper 8 bits of compare register 4 (TM4OCH).
- (7) Set the TM4EN flag of the TM4MD register to "1" to start the timer.
- (8) When timer 4 begins operation, binary counter 4 will count upward from X'00'.
- (9) A high-level signal is output from the port beginning when binary counter 4 starts counting from X'00' and ending when the value of binary counter 4 matches the value set in the TM4OCL register.
- (10) When the value of binary counter 4 matches that of the TM4OCL register, a low-level signal is output from the port.
- (11) Binary counter 4 continues to count upward until X'FF' is reached. At the next count-up cycle, the value of binary counter 4 is reset to X'00', and counting begins again. A high-level signal is output from the port.

 Use a 16-bit access instruction to set the TM4OCH, TM4OCL register.

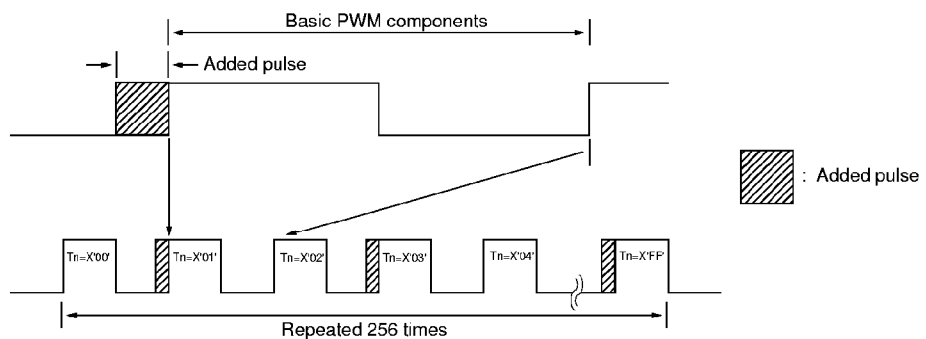

Figure 4-4-5 Pulse Added Type PWM Output

■ Setting the Added Pulse Position

[^{MS} 5-2-3 "Serial Interface Transfer Timing"]

The upper 8 bits of compare register 4 (TM4OCH) set the position of the added pulse. If the TM4OCH register is set to X'00', an additional bit is not appended to the basic PWM component. If the TM4OCH register is set to X'FF', an additional bit is repeatedly appended to the 255 basic PWM components during the period. The relation between the value set in the TM4OCH register and the added pulse is shown in the table below. If X'03' is set in the TM4OCH register, bits are appended to pulse positions for X'01' and X'02', shown in table 4-4-1. The relation between the value set in the TM4OCH register and the position of the added bit is shown in figure 4-4-6.

Table 4-4-1 Pulse-Added PWM Output

Value Set in TM4OCH Register	Added Pulse Position (value of Tn)
0 0 0 0 0 0 0 0	
0 0 0 0 0 0 0 1	X'80'
0 0 0 0 0 0 1 0	X'40', X'C0'
0 0 0 0 0 1 0 0	X'20', X'60', X'A0', X'E0'
0 0 0 0 1 0 0 0	X'10', X'30', X'50', X'70', X'90', X'B0', X'D0', X'F0'
0 0 0 1 0 0 0 0	X'08', X'18', X'28', X'38', X'48', X'58', X'E8', X'F8'
0 0 1 0 0 0 0 0	X'04', X'0C', X'14', X'1C', X'24', X'2C', X'F4', X'FC'
0 1 0 0 0 0 0 0	X'02', X'06', X'0A', X'0E', X'12', X'16', X'FA', X'FE'
1 0 0 0 0 0 0 0	X'01', X'03', X'05', X'07', X'09', X'0B', X'FD', X'FF'
(MSB)	(LSB)

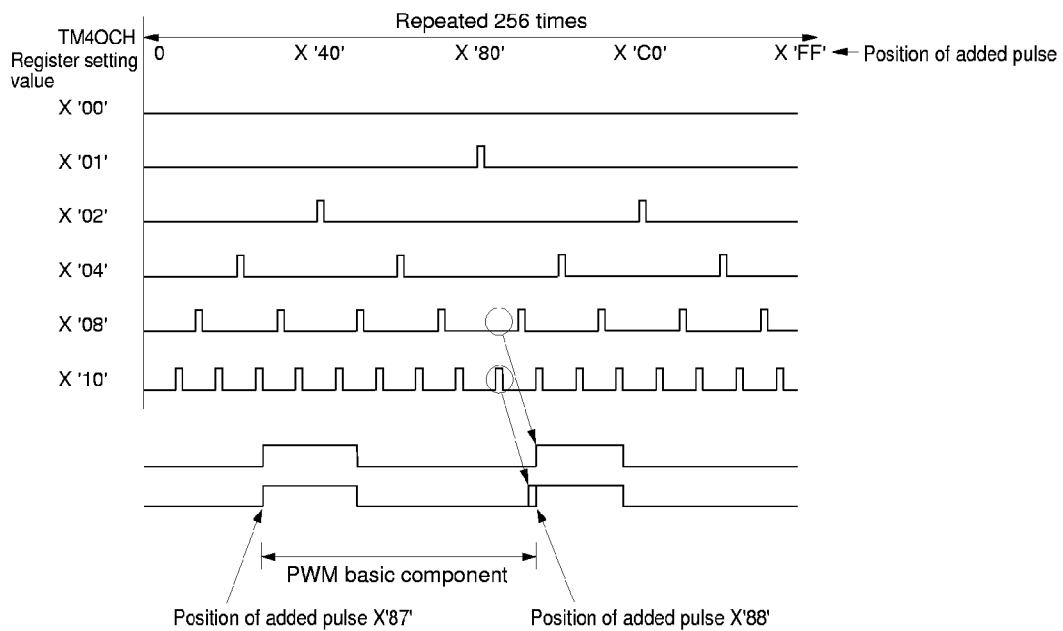

Figure 4-4-6 Pulse Added Type PWM Output

■ Capture Function

Settings for the capture function are listed below.

- (1) Set the TM4EN flag of the timer 4 mode register (TM4MD) to "0" to stop the count operation of timer 4.
- (2) Use the TM4CK2~0 flags of the TM4MD register to select fosc, fs/4, or fs/16 as the clock source. The period of the output waveform is determined based on the clock source.
- (3) Use the T4ICTS1 and T4ICTS0 flags of the TM4MD register to select IRQ2, IRQ1, or IRQ0 as the input capture trigger.
- (4) Set the REDGn flag of the external interrupt control register to specify the valid edge for the interrupt selected as the TM4 input capture trigger.
- (5) Set the TM4PWM flag of the TM4MD register to "1" to select 16-bit timer operation.
- (6) Set a value in compare register 4 (TM4OCH, TM4OCL).
- (7) Set the TM4EN flag of the TM4MD register to "1" to start the timer.
- (8) When timer 4 begins operation, binary counter 4 will count upward from X'0000' until it reaches the value set in compare register 4.
- (9) If the binary counter is to be used as a free-running counter that counts from X'0000'~X'FFFF', set the compare register 4 to X'FFFF'.
When the value of binary counter 4 matches that of the TM4OCH, TM4OCL register, the timer 4 interrupt request flag is set, binary counter 4 is reset to X'0000', and counting begins again.
- (10) If the external interrupt selected as the TM4 input capture trigger is received during timer 4 operation, the value of binary counter 4 will be written into the input capture register (TM4ICHI, TM4ICL).

Setting a value in compare register 4, clears binary counter 4.

If the event occurs before a read, that data will be overwritten.

4-5 8-bit Timer Operation (timer 5)

4-5-1 Overview

Timer 5 is an 8-bit timer that can have f_{osc} , $f_s/4$, f_x , or time base output as its clock source.

4-5-2 Operation

■ Timer Operation

Settings for timer operation are listed below.

- (1) Set the TM5CLRS flag of the timer 5 mode register (TM5MD) to "0."
- (2) Use the TM5CK3~1 flags of the TM5MD register to select f_{osc} , $f_s/4$, f_x , synchronized f_x , time base timer output, or time base timer synchronized output as the clock source.
- (3) Set a value in compare register 5 (TM5OC). At this time, if the TM5CLRS flag is "0," binary counter 5 will be initialized to X'00'.
- (4) Binary counter 5 (TM5OC) counts upward from X'00'.
- (5) When the value of binary counter 5 matches that of the TM5OC register, the timer 5 interrupt request flag is set, the binary counter is reset to X'00', and counting begins again.

When servicing an interrupt, reset the timer 5 interrupt request flag before starting timer 5.

When choosing either time base timer output or time base timer synchronized output for the timer 5 clock source, the time base must be set up.

During a count operation, be careful if the value set in TM5OC is smaller than the value of binary counter 5, since the count-up operation will continue until overflow occurs.

If f_x input is selected as the clock source and the value of binary counter 5 is to be read during operation, select synchronized f_x input to avoid reading data that may be incomplete during count-up transitions. However, with synchronized f_x input, it is not possible to return from STOP/HALT modes.



If the TM5CLRS flag of the TM5MD register is set to "0," binary counter 5 will be initialized every time data in the TM5OC register is overwritten. Timer 5 interrupts are disabled in this mode. If timer 5 interrupts are to be used, the TM5CLRS flag must be reset to "1" after writing to the TM5OC register.



Timer 5 operation cannot be halted.

4-6 Time Base Operation

4-6-1 Overview

The clock source for the time base timer can be set to f_{osc} or f_x . Also, the interrupt period for time base timer (TBIRQ) can be set to $1/2^7$, $1/2^8$, $1/2^9$, $1/2^{10}$, or $1/2^{13}$ of the clock source.

4-6-2 Operation

■ Time Base Function

Settings for the time base function are listed below.

- (1) Use the TM5CK0 flag of the timer 5 modc register (TM5MD) to select f_{osc} or f_x as the clock source.
- (2) Use the TM5IR2~0 flags of the TM5MD register to select the time base timer interrupt source.
- (3) When the selected time interval passes, the interrupt request flag of the time base interrupt control register (TBICR) is set.



Time base operation cannot be halted.

Table 4-6-1 Base Time Settings

Clock Source \ TM5IR2~0		000	001	010	011	1XX
		$\frac{1}{2^7}$	$\frac{1}{2^8}$	$\frac{1}{2^9}$	$\frac{1}{2^{10}}$	$\frac{1}{2^{13}}$
f_{osc}	20MHz	6.4 μ s	12.8 μ s	25.6 μ s	51.2 μ s	409.6 μ s
	8.38MHz	15.2 μ s	30.5 μ s	61.0 μ s	122.0 μ s	976.4 μ s
f_x	32.768kHz	3.9ms	7.8ms	15.6ms	31.2ms	250ms

4-7 Watchdog Timer Operation

4-7-1 Overview

The watchdog timer is controlled by the watchdog control register (WDCTR) and can be used for runaway program detection.

4-7-2 Setup and Operation

- (1) Set the WDEN flag of the watchdog timer control register (WDCTR) to "1" to start the watchdog timer.
- (2) Operate the watchdog timer by clearing the WDEN flag to "0" within the fixed amount of time (T_{wd}), and then resetting the WDEN flag to "1."
If the WDEN flag is not cleared, a WDT interrupt will be generated after the fixed amount of time passes.
- (3) When a runaway of program is detected, the program encoded at the location of the WDT interrupt routine is executed.

T_{wd} is set by the mask option as $fs/2^{16}$, $fs/2^{18}$, or $fs/2^{20}$.

The upper 2 bits of the watchdog timer are cleared when the WDEN flag is set to "0." Therefore, depending on the timing of this clear the watchdog timer may be reset at $3/4T_{wd}$. If the WDEN bit is to be repeatedly cleared and set at regular intervals, those operations should be performed within $3/4$ of the T_{wd} period.

4-8 Remote Control Output Operation

4-8-1 Overview

A remote control carrier pulse can be generated using the overflow of timer 3. Two duty ratios of 1/2 or 1/3 can be selected.

4-8-2 Setup and Operation

Set bit 0 of the P10MD register to "1" at the same time the remote control output is switched on, and to "0" at the same time the remote control output is switched off.

- (1) Set the RMOEN flag of the remote control output control register (RMCTR) to "0" so that the remote control carrier output is switched off. Set the RMBTMS flag to select the base period timer for the remote control carrier.
- (2) Set timer 0 or timer 3 to select the base period of the remote control carrier (the width that the remote control carrier output pulse is held at a high level).
- (3) Set the RMDTY0 flag of the RMCTR register to select the carrier duty.
- (4) Set the P10 output data to "0" and set P10 to the output mode. Also, set TM0RM flag of the RMCTR register to "0" and select remote control carrier output.
- (5) The RMOEN flag of the RMCTR register controls whether the remote control carrier output is on or off.
Even if the carrier output is at a high level, and the RMOEN flag is set to "0" (off), the carrier waveform will be maintained by the synchronous circuit.

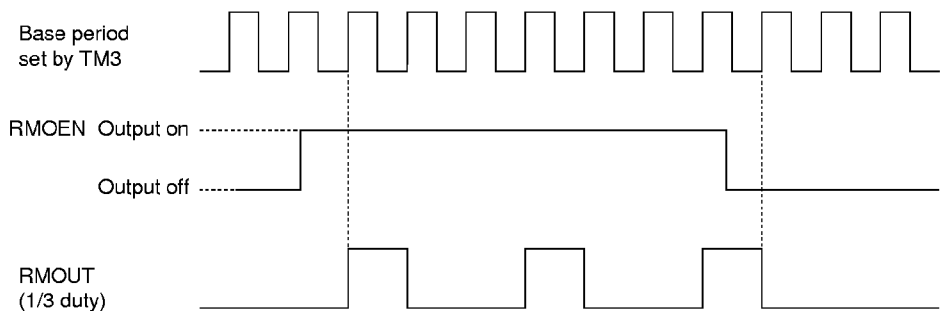

Figure 4-8-1 Remote Control Carrier Output Waveform

4-9 Buzzer Output

4-9-1 Buzzer Output Setup and Operation

The square wave having a frequency $1/2^9 \sim 1/2^{12}$ of the system clock can be output from the P06/BUZZER pin.

- (1) Set the BUZOE flag of the oscillation stabilization wait control register (DLYCTR) to "0" so that the buzzer output is turned off.
- (2) Set the buzzer output frequency with the BUZCK1 and BUZCK0 flags of the DLYCTR.
- (3) Set the BUZOE flag of the DLYCTR register to "1" and set P06 to the buzzer output mode.
- (4) The BUZOE flag of the DLYCTR register controls whether the buzzer output is on or off.

4-10 Timer Function Control Registers

4-10-1 Overview

Twenty-five registers control the timers. See table 4-10-1.

Table 4-10-1 Timer Control Registers

Name	Address	R/W	Function
TM0OC	X'03F70'	R/W	Compare register 0
TM0BC	X'03F60'	R	Binary counter 0
TM0MD	X'03F80'	R/W	Timer 0 mode register
TM1OC	X'03F71'	R/W	Compare register 1
TM1BC	X'03F61'	R	Binary counter 1
TM1MD	X'03F81'	R/W	Timer 1 mode register
TM2OC	X'03F72'	R/W	Compare register 2
TM2BC	X'03F62'	R	Binary counter 2
TM2MD	X'03F82'	R/W	Timer 2 mode register
TM3OC	X'03F73'	R/W	Compare register 3
TM3BC	X'03F63'	R	Binary counter 3
TM3MD	X'03F83'	R/W	Timer 3 mode register
TM4OCL	X'03F74'	R/W	Compare register 4 (lower 8 bits)
TM4OCH	X'03F75'	R/W	Compare register 4 (upper 8 bits)
TM4BCL	X'03F64'	R	Binary counter 4 (lower 8 bits)
TM4BCH	X'03F65'	R	Binary counter 4 (upper 8 bits)
TM4ICL	X'03F66'	R	Input capture register (lower 8 bits)
TM4ICH	X'03F67'	R	Input capture register (upper 8 bits)
TM4MD	X'03F84'	R/W	Timer 4 mode register
TM5OC	X'03F78'	R/W	Compare register 5
TM5BC	X'03F68'	R	Binary counter 5
TM5MD	X'03F88'	R/W	Timer 5 mode register
WDCTR	X'03F02'	R/W	Watchdog timer control register
DLYCTR	X'03F03'	R/W	Oscillation stabilization wait control register
RMCTR	X'03F89'	R/W	Remote control carrier output control register

R/W: Readable and writable

R: Read only

4-10-2 Programmable Timer/Counters

Timers 0~5 all contain a programmable 8-bit timer/counter (16-bit in timer 4). Programmable timer/counters consist of a compare register and a binary counter.

(1) Compare register 0 (TM0OC)

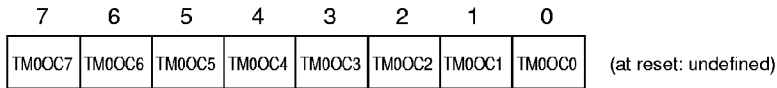

Figure 4-10-1 Compare Register 0 (TM0OC: X'03F70', R/W)

(2) Binary counter 0 (TM0BC)



Figure 4-10-2 Binary Counter 0 (TM0BC: X'03F60', R)

(3) Compare register 1 (TM1OC)

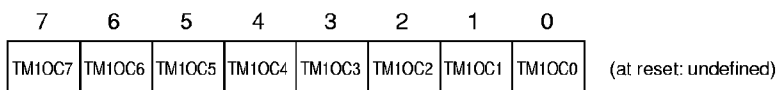

Figure 4-10-3 Compare Register 1 (TM1OC: X'03F71', R/W)

(4) Binary counter 1 (TM1BC)



Figure 4-10-4 Binary Counter 1 (TM1BC: X'03F61', R)

(5) Compare register 2 (TM2OC)



Figure 4-10-5 Compare Register 2 (TM2OC: X'03F72', R/W)

(6) Binary counter 2 (TM2BC)

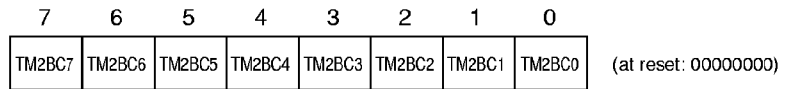

Figure 4-10-6 Binary Counter 2 (TM2BC: X'03F62', R)

(7) Compare register 3 (TM3OC)



Figure 4-10-7 Compare Register 3 (TM3OC: X'03F73', R/W)

(8) Binary counter 3 (TM3BC)



Figure 4-10-8 Binary Counter 3 (TM3BC: X'03F63', R)

(9) Compare register 4 (TM4OCL) (lower 8 bits)



Figure 4-10-9 Compare Register 4 (TM4OCL: X'03F74', R/W)

(10) Compare register 4 (TM4OCH) (upper 8 bits)

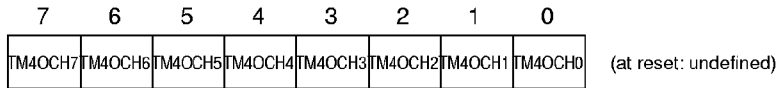

Figure 4-10-10 Compare Register 4 (TM4OCH: X'03F75', R/W)

(11) Binary counter 4 (TM4BCL) (lower 8 bits)

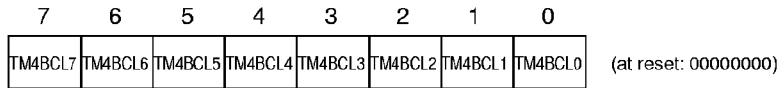

Figure 4-10-11 Binary Counter 4 (TM4BCL: X'03F64', R)

(12) Binary counter 4 (TM4BCH) (upper 8 bits)

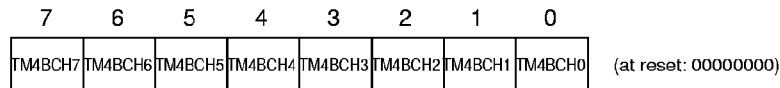

Figure 4-10-12 Binary Counter 4 (TM4BCH: X'03F65', R)

(13) Input capture register (TM4ICL) (lower 8 bits)

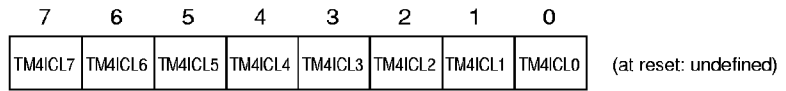

Figure 4-10-13 Input Capture Register (TM4ICL: X'03F66', R)

(14) Input capture register (TM4ICH) (upper 8 bits)

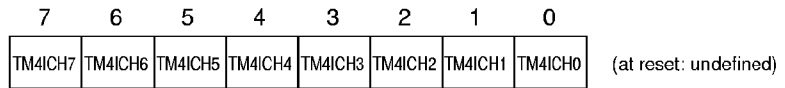

Figure 4-10-14 Input Capture Register (TM4ICH: X'03F67', R)

(15) Compare register 5 (TM5OC)

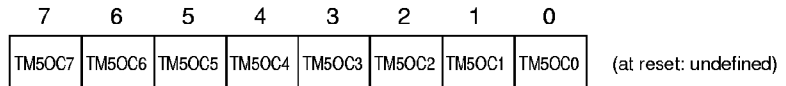

Figure 4-10-15 Compare Register 5 (TM5OC: X'03F78', R/W)

(16) Binary counter 5 (TM5BC)



Figure 4-10-16 Binary Counter 5 (TM5BC: X'03F68', R)

4-10-3 Timer Mode Registers

Four readable and writable timer mode registers. Control timers 0, 1, 2, 3, 4, 5, and the time base.

(1) Timer 0 mode register (TM0MD)

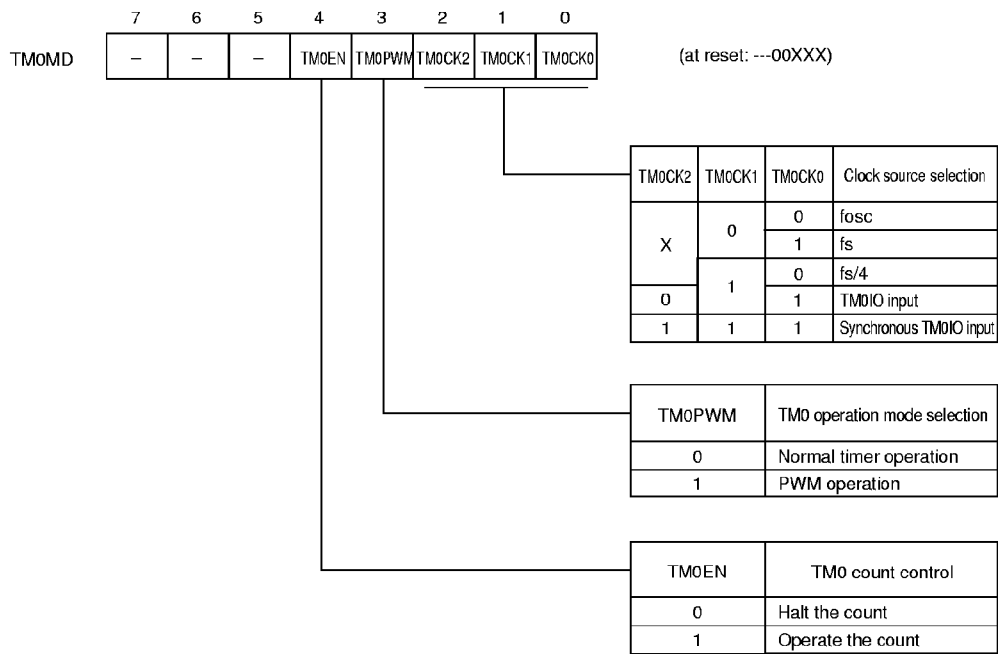

Figure 4-10-17 Timer 0 Mode Register (TM0MD: X'03F80', R/W)

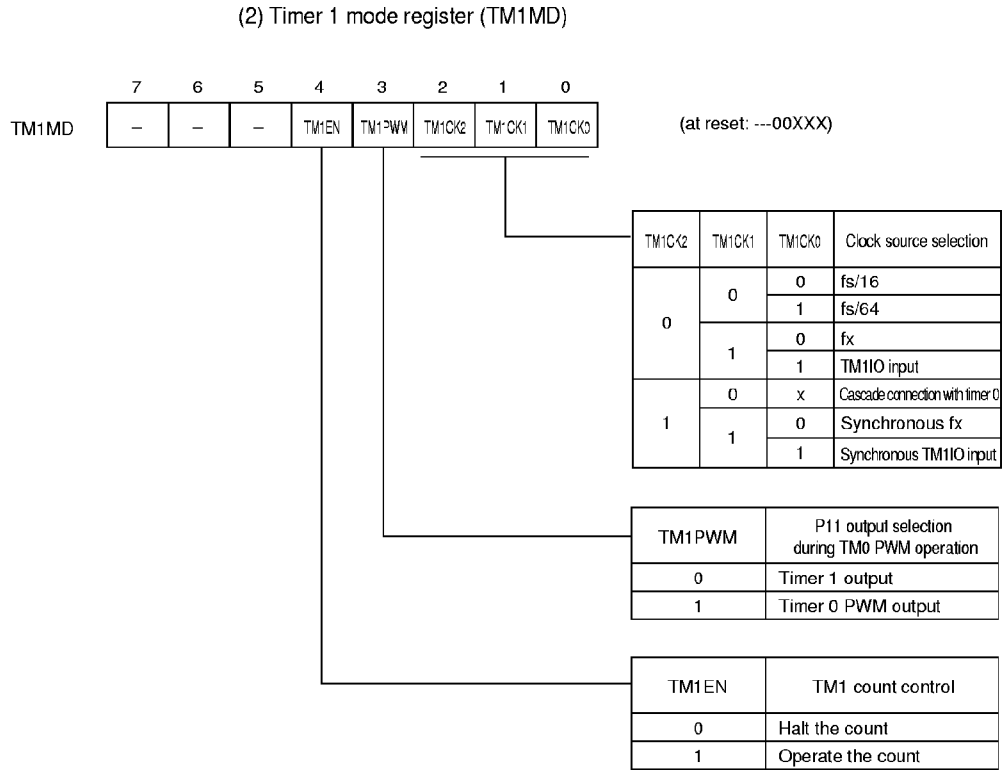

Figure 4-10-18 Timer 1 Mode Register (TM1MD: X'03F81', R/W)

(3) Timer 2 mode register (TM2MD)

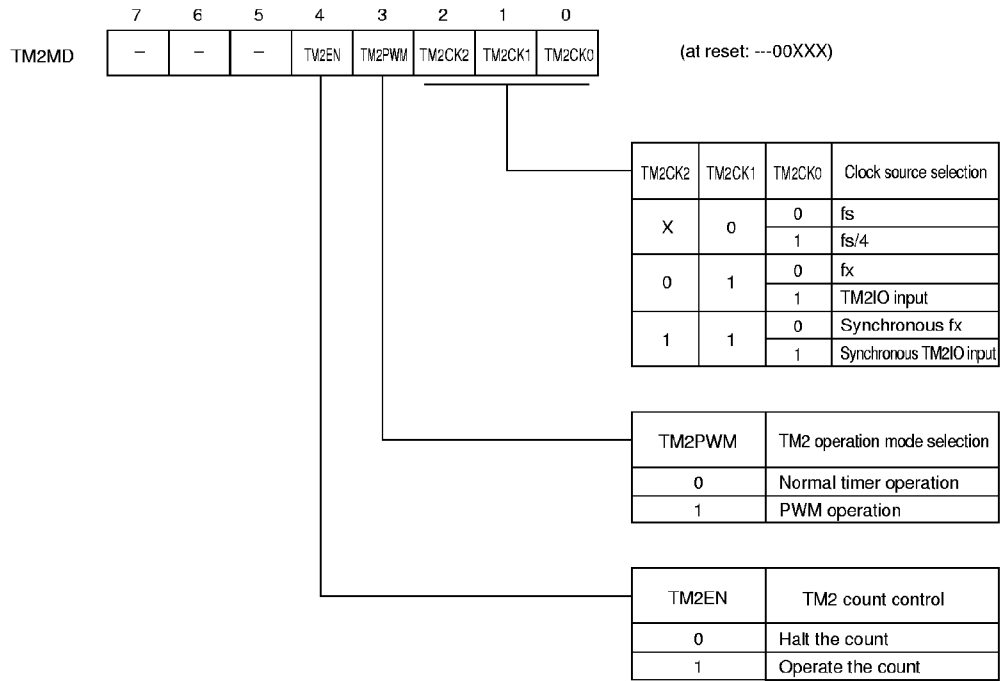

Figure 4-10-19 Timer 2 Mode Register (TM2MD: X'03F82', R/W)

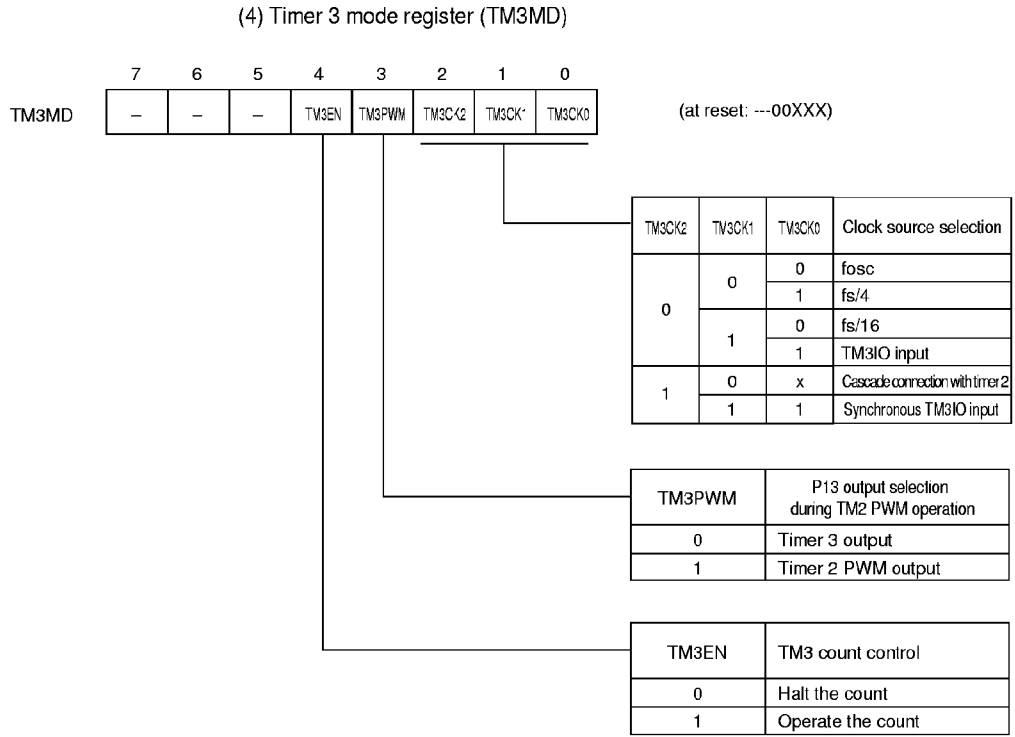

Figure 4-10-20 Timer 3 Mode Register (TM3MD: X'03F83', R/W)

(5) Timer 4 mode register (TM4MD)

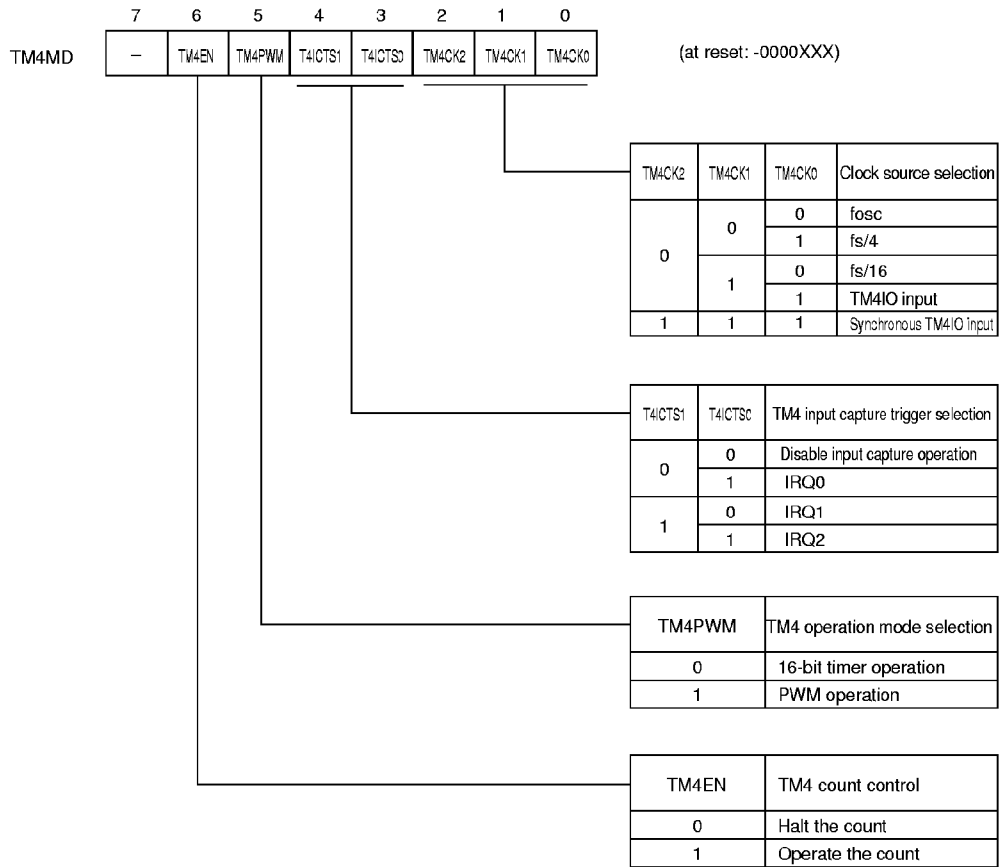

Figure 4-10-21 Timer 4 Mode Register (TM4MD: X'03F84', R/W)

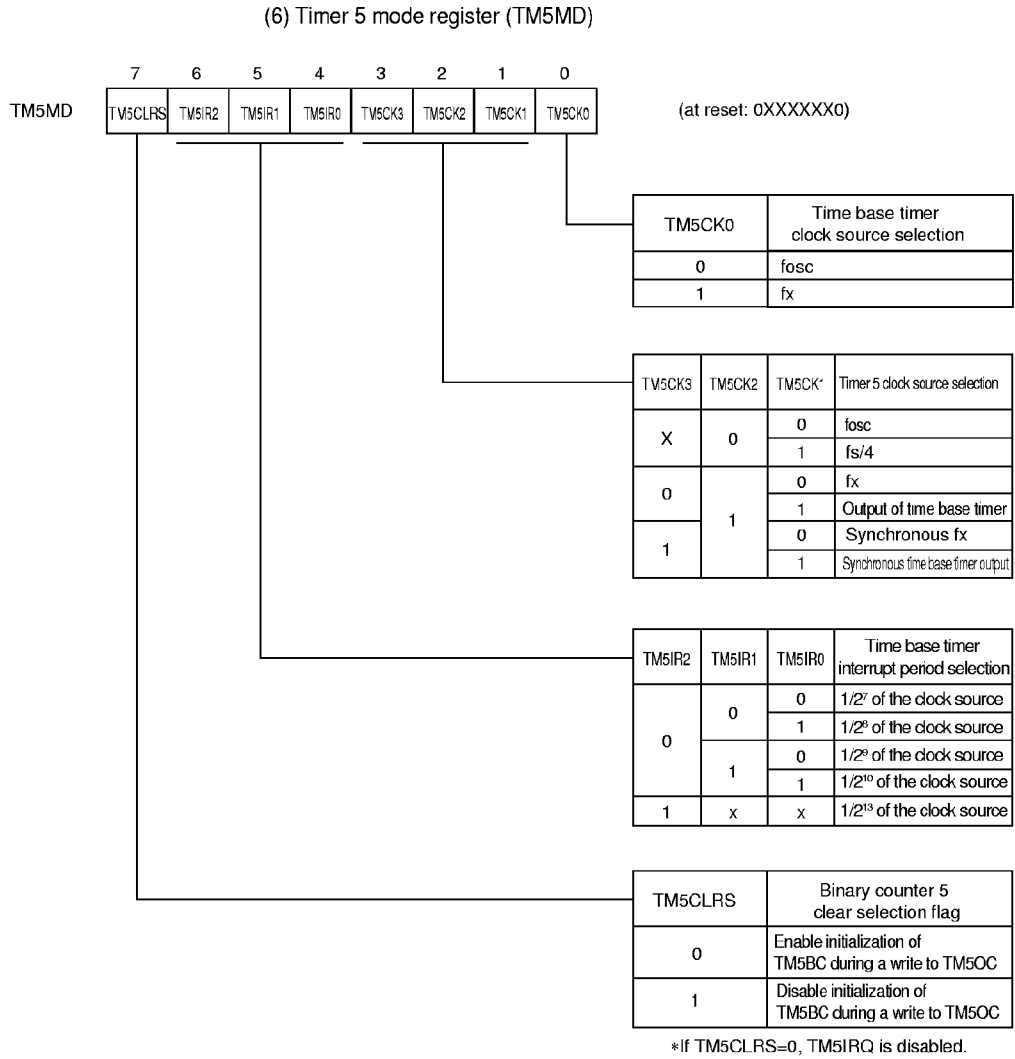

Figure 4-10-22 Timer 5 Mode Register (TM5MD: X'03F88', R/W)

4-10-4 Timer Control Registers

(1) Watchdog timer control register (WDCTR)

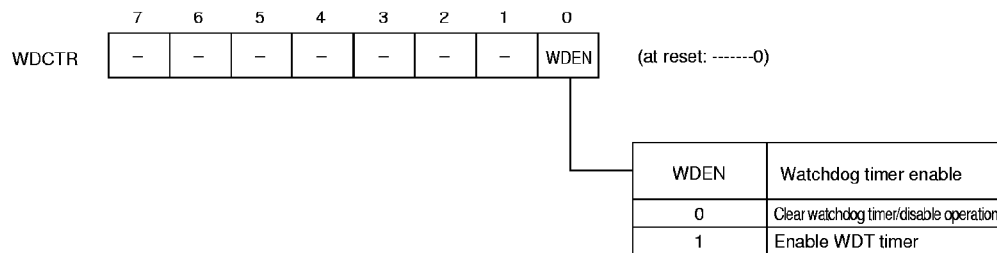

Figure 4-10-23 Watchdog Timer Control Register (WDCTR: X'03F02', R/W)

(2) Oscillation stabilization control register (DLYCTR)

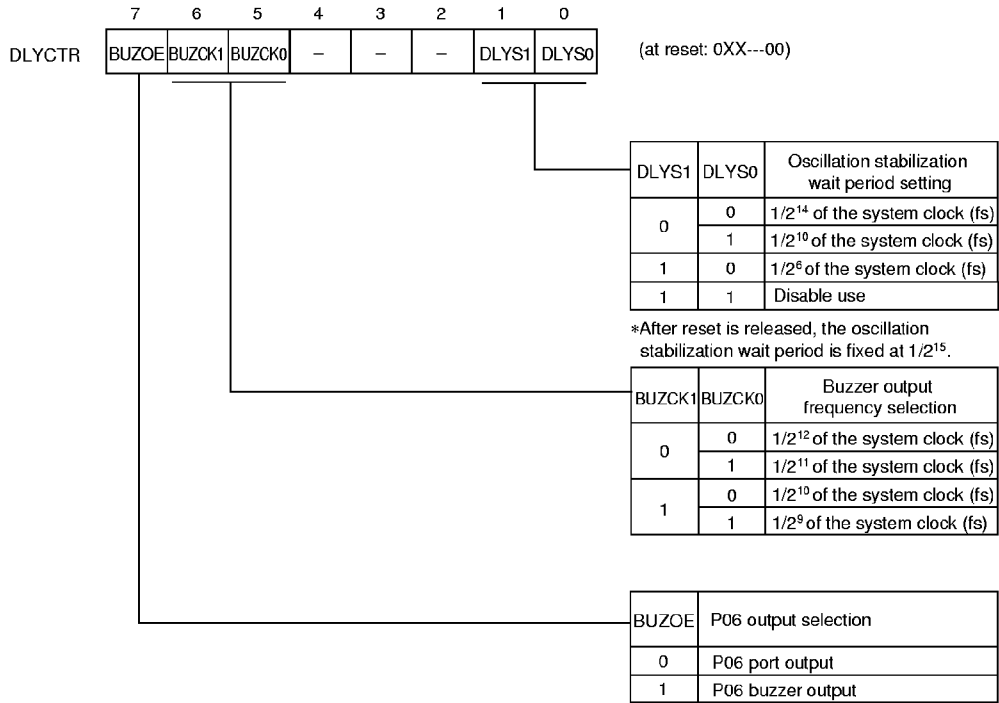

Figure 4-10-24 Oscillation Stabilization Wait Counter Control Register (DLYCTR: X'03F03', R/W)

(3) Remote control carrier output control register (RMCTR)

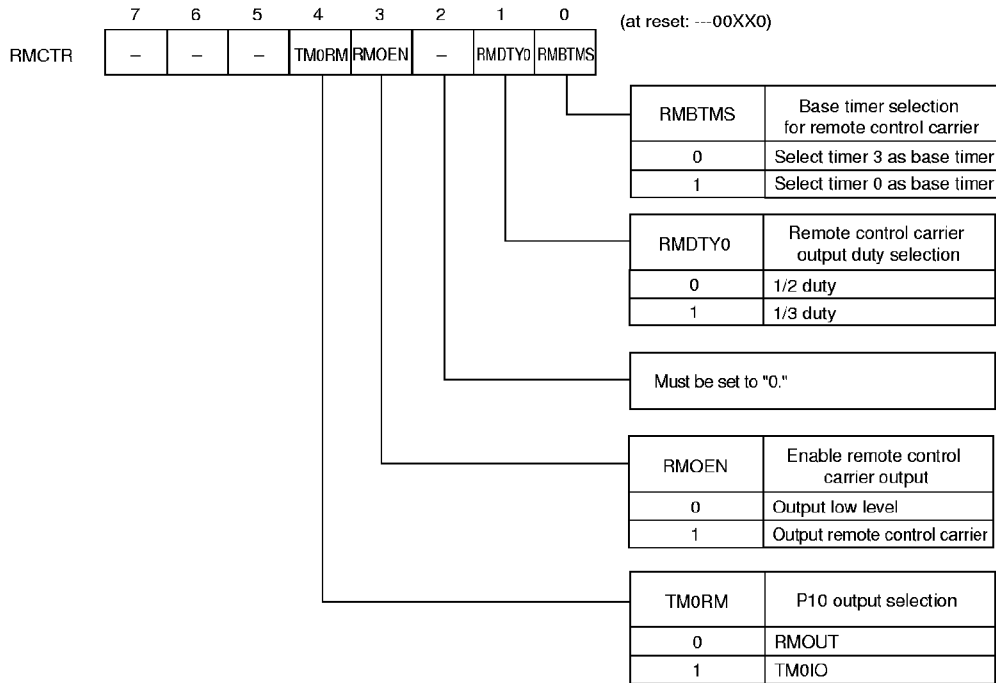

Figure 4-10-25 Remote Control Carrier Control Register
(RMCTR: X'03F89', R/W)

(2) Oscillation stabilization control register (DLYCTR)

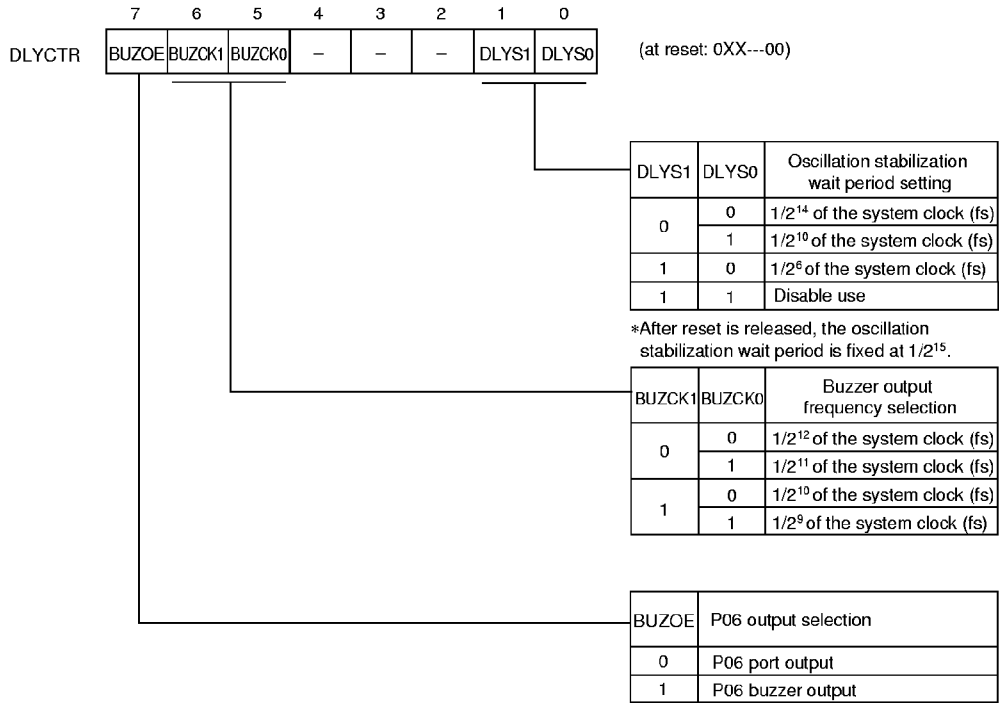

Figure 4-10-24 Oscillation Stabilization Wait Counter Control Register (DLYCTR: X'03F03', R/W)

Chapter 5 Serial Functions



5-1 Overview

The MN101C01D contains a serial interface that can operate in synchronous and simple UART modes.

An overview of serial functions is shown below.

Table 5-1-1 Overview of Serial Functions

	Serial 0	Serial 1	Serial 2
Interrupt	SC0ICR	SC1ICR	SC2ICR
Synchronous	✓	✓	✓
Simple UART	✓	—	—
Simple IIC	—	—	✓
Clock selection	fs/2 fs/4 fs/16 BC3×1/2 External	fs/2 fs/8 fs/64 BC3×1/2 External	fs fs/2 fs/4 fs/8 BC0×1/2 External
1/8 clock frequency	✓	—	—

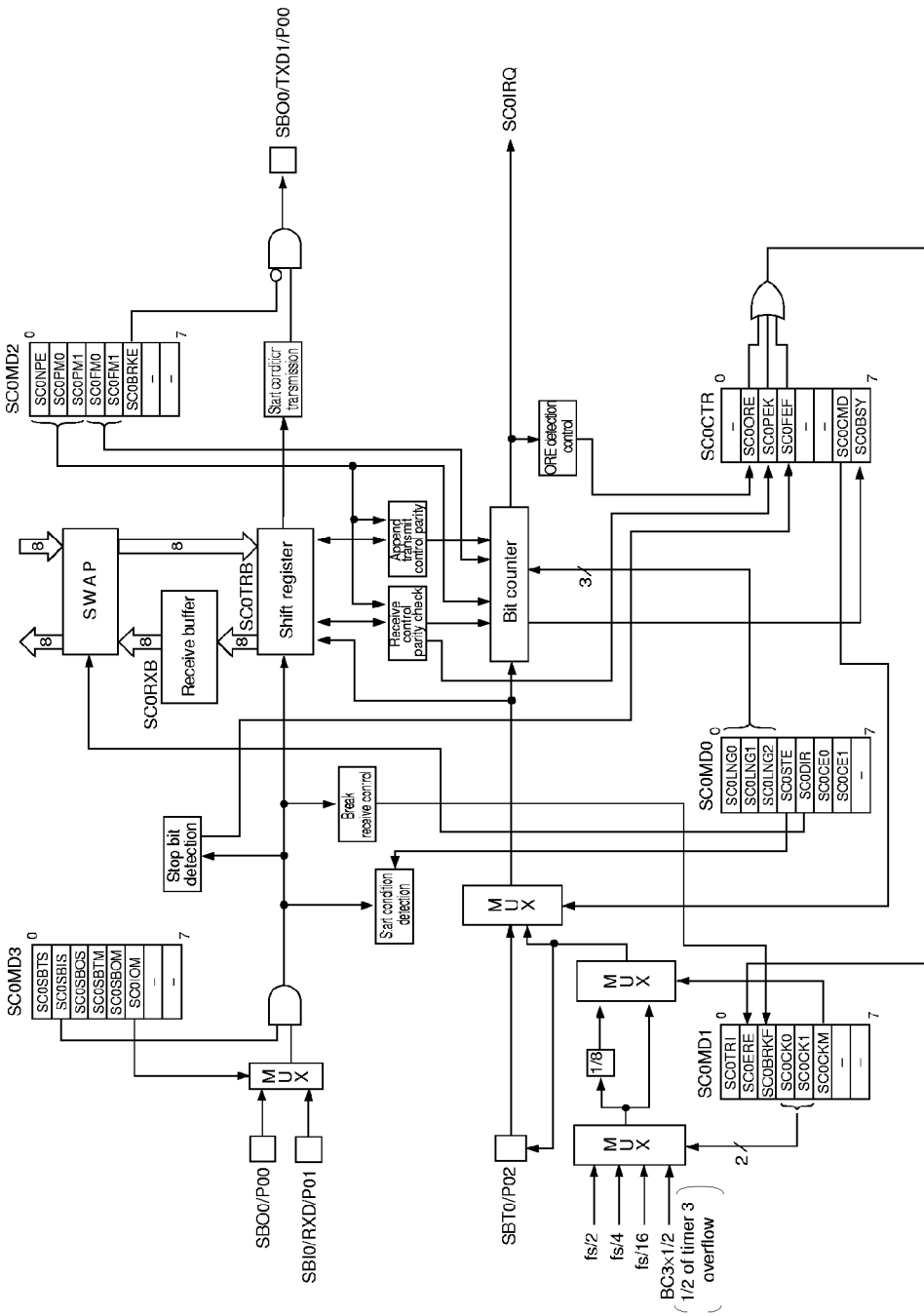
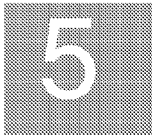

Figure 5-1-1 Serial 0 Block Diagram



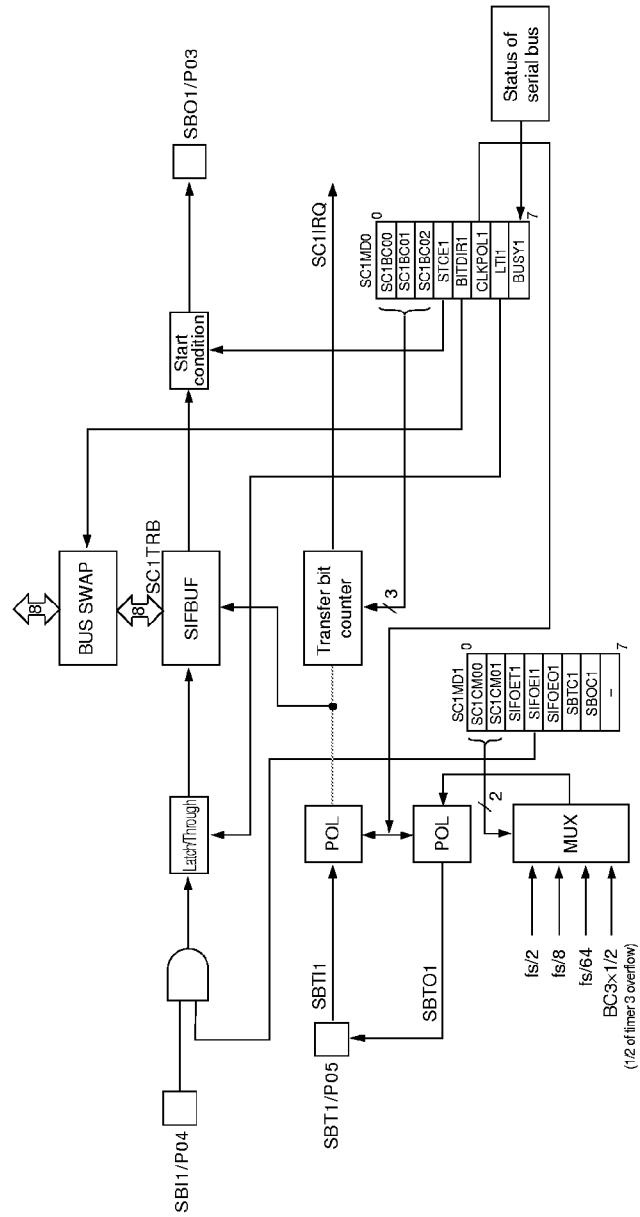

Figure 5-1-2 Serial 1 Block Diagram

5-2 Synchronous Serial Interface

5-2-1 Overview

A serial interface begins operation when data is written to the shift buffer. A bit counter is incremented at each 1-bit transfer. The transfer is complete when the counter overflows.

Bit transfers of an arbitrary 1~8 bits can be performed. The transfer bit count must be set before performing the transfer.

5-2-2 Setup and Operation

■ Transmission

- (1) Select the synchronous serial interface by setting the SCOCMD flag of the serial interface 0 control register (SCOCTR) to "0."
- (2) Select the transfer bit count with the SCOLNG2~0 flags of the serial interface 0 mode register 0 (SCOMD0). The transfer bit count can be set as 1 to 8 bits.
- (3) Specify whether the start condition is enabled or disabled with the SCOSTE flag of the SCOMD0 register.
- (4) Specify the first bit to be transferred (MSB first or LSB first) with the SCODIR flag of the SCOMD0 register.
- (5) Select the valid edge of the clock signal with the SCOCE1~0 flags of the SCOMD0 register.
- (6) When the clock source is an internal clock:
 - Select the clock source with the SCOCK1~0 flags of serial interface 0 mode register 1 (SCOMD1).
 - Set the SCOCKM flag of the SCOMD1 register specify whether or not the clock source frequency will be divided by 8.
 - Select serial clock operation by setting the SCOSBTS flag of the serial interface 0 mode register 3 (SCOMD3) to "1."
 - Set the SCOSBTM flag of the SCOMD3 register.
 - Set bit 0 of the port 0 direction control register (PODIR) to the output mode.
 - Set bit 0 of the port 0 pull-up resistor control register (POPLU).

[¹⁵⁸ Section 5-2-3, "Serial Interface Transfer Timing"]

When the clock source is an external clock (SBT0 pin input):

- Set the SC0SBTM flag of the SC0MD3 register.
 - Set bit 0 of the PODIR register to input mode.
 - Set bit 0 of the POPLU register.
- (7) Select the SC0SBOM flag of the SC0MD3 register.
 - (8) Select the SC0IOM flag of the SC0MD3 register.
 - (9) Select serial communication by setting the SC0SBOS flag of the SC0MD3 register to "1."
 - (10) Set transmit data to serial interface 0 transmit/receive shift register (SC0TRB). This will start the serial transmission.
 - (11) When serial transmission begins, the SC0BSY flag of the SC0CTR register is set to "1," indicating that a serial transfer is in progress.
 - (12) When the serial transmission has completed, the SC0BSY flag of the SC0CTR register is cleared to "0" and the SC0 transfer complete interrupt request flag is set to "1." The SC0TRI flag of SC0MD1 register 1 is cleared to "0."



After the transfer is complete, the transfer bit count in the SC0LNG2~0 flags of the SC0MD0 register will be changed. Except in an 8-bit transfer, reset the transfer bit count at the time of the next transmission.



When switching from transmission to reception, set the SC0SBOS flag of the SC0MD3 register to "0" and then set the SC0SBIS flag to "1." Do not change both of these flags at the same time.



The SC0SBTS flag of the SC0MD3 register must be set to "1" before the SC0SBOS flag of the SC0MD3 register is set to "1."

When the serial port is enabled and the SC0CE1~0 flags of the SC0MD0 register are changed, the transfer bit count in the SC0LNG2~0 flags of the SC0MD0 register may be incremented.

Enabling the start condition drives the SBO0 pin high for a fixed time interval (1/2 the clock source cycle) after the transmission is completed. If the start condition is disabled, the SBO0 pin will remain at the value of the of the last data bit.

If the SC0IOM flag of the SC0MD3 register is set for a pin connection, the SBI0 pin can be used as a port. The SBO0 pin receives data during the input mode and transmits data during the output mode.

The SC0LNG2~0 flags change at the opposite edge of the transmit data output edge.

Serial interface 0 begins operation when the SC0SBOS flag or the SC0SBIS flag is set to "1." Set the SC0SBOS flag or the SC0SBIS flag after all conditions have been set.

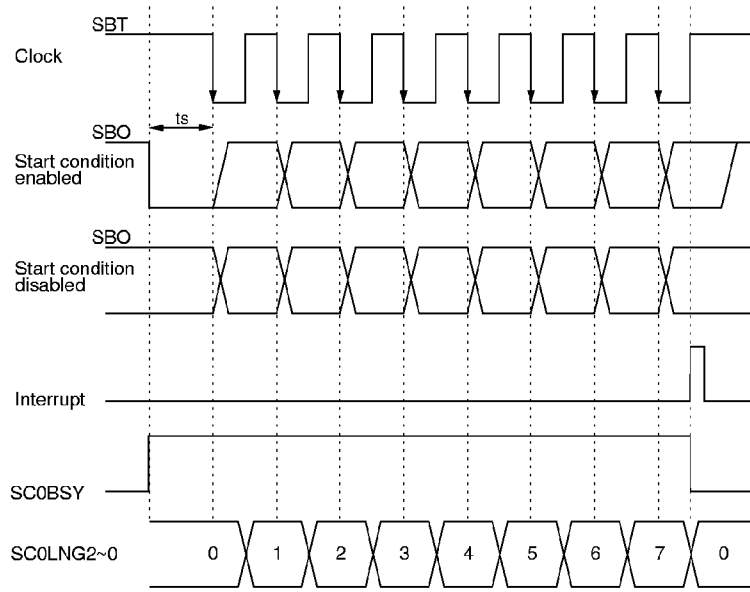

Figure 5-2-1 Synchronous Serial Interface Transmission Timing (falling edge)

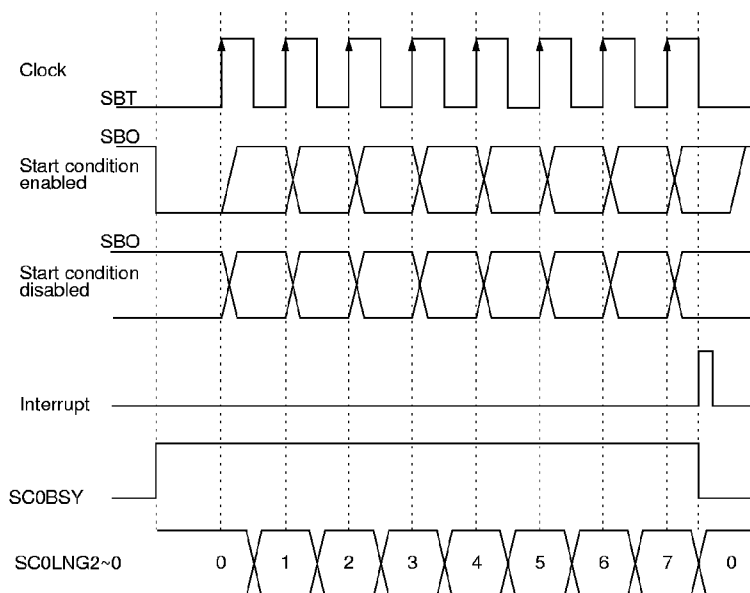

Figure 5-2-2 Synchronous Serial Interface Transmission Timing (rising edge)

■ Reception

- (1) Select the synchronous serial interface by setting the SC0CMD flag of the serial interface 0 control register (SC0CTR) to "0."
- (2) Select the transfer bit count with the SC0LNG2~0 flags of the serial interface 0 mode register 0 (SC0MD0). The transfer bit count can be set as 1 to 8 bits.
- (3) Specify whether the start condition is enabled or disabled with the SC0STE flag of the SC0MD0 register.
- (4) Specify the first bit to be transferred (MSB first or LSB first) with the SC0DIR flag of the SC0MD0 register.
- (5) Select the valid edge of the clock signal with the SC0CE1~0 flags of the SC0MD0 register.
- (6) When the clock source is an internal clock:
 - Select the clock source with the SC0CK1~0 flags of serial interface 0 mode register 1 (SC0MD1).
 - Set the SC0CKM flag of the SC0MD1 register to specify whether or not the clock source frequency will be divided by 8.
 - Select serial clock pin operation by setting the SC0SBTS flag of the serial interface 0 mode register 3 (SC0MD3) to "1."
 - Set the SC0SBTM flag of the SC0MD3 register.
 - Set bit 2 of the port 0 direction control register (P0DIR) to the output mode (P02/SBT0 output mode).
 - If necessary, set bit 2 of the port 0 pull-up resistor control register (POPLU) to add the pull-up resistor.
 When the clock source is an external clock (SBT0 pin input):
 - Set bit 2 of the P0DIR register to the input mode.
 - If necessary, set bit 2 of the POPLU register.
- (7) Select the SC0IOM flag of the SC0MD3 register.
- (8) Select serial communication by setting the SC0SBIS flag of the SC0MD3 register to "1." (Reception data wait.)
- (9) When the serial reception begins, the SC0BSY flag of the serial interface 0 control register (SC0CTR) is set to "1," indicating that a serial transfer is in progress.
- (10) When the serial reception is complete, the SC0BSY flag of the SC0CTR register is cleared to "0" and the SC0 transfer complete interrupt request flag is set to "1." The SC0TRI flag of the SC0MD1 register is set to "1."



After the transfer is complete, the transfer bit count in the SC0LNG2~0 flags of the SC0MD0 register will be changed. Except in an 8-bit transfer count, reset the transfer bit count at the time of the next reception.



When switching from reception to transmission, set the SC0SBIS flag of the SC0MD3 register to "0" and then set the SC0SBOS flag to "1." Do not change both of these flags at the same time.

When the serial port is enabled and the SC0CE1~0 flags of the SC0MD0 register are changed, the transfer bit count in the SC0LNG2~0 flags of the SC0MD0 register may be incremented.

[☞ Section 5-2-3, "Serial Interface Transfer Timing"]

If the start condition is enabled, the SC0LNG2~0 flags of the SC0MD0 register will be cleared when the start condition is received. In this case, the receive bit count is fixed at 8 bits.

The SC0SBTS flag of the SC0MD3 register must be set to "1" before setting the SC0SBIS flag of the SC0MD3 register to "1."

If the internal clock is selected as the clock source, after setting the SC0SBIS flag of the SC0MD3 register to "1," write dummy data to the SC0TRB register. If there is to be another reception, write dummy data again to the SC0TRB register.

The SC0LNG2~0 flags change at the opposite edge of the transmit data output edge.

Serial interface 0 begins operation when the SC0SBOS flag or the SC0SBIS flag is set to "1." Set the SC0SBOS flag or the SC0SBIS flag after all conditions have been set.

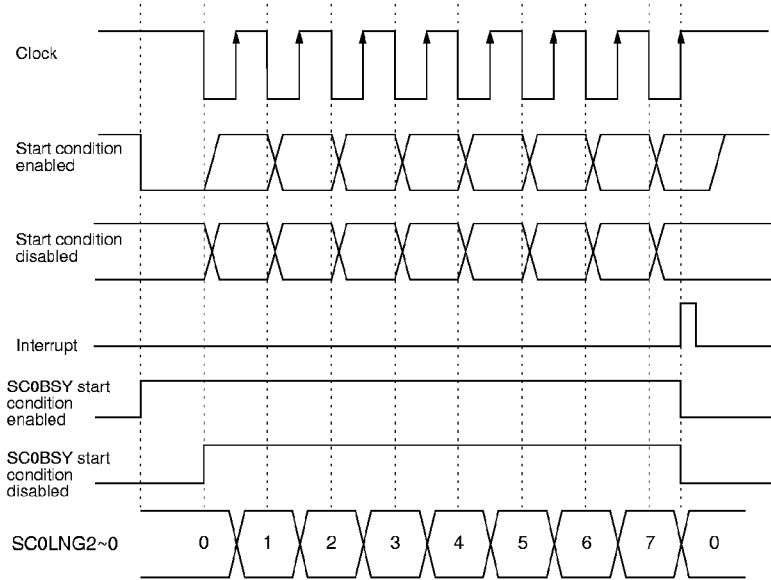

Figure 5-2-3 Synchronous Serial Interface Reception Timing (reception at rising edge)

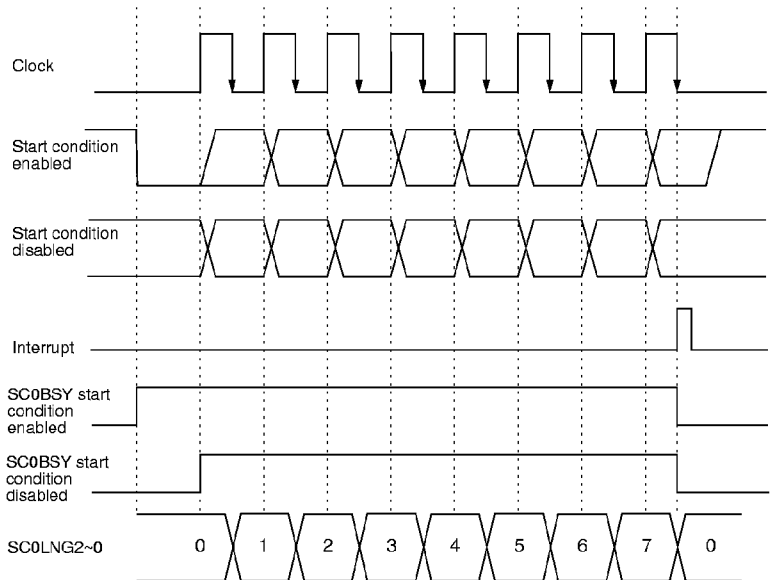

Figure 5-2-4 Synchronous Serial Interface Reception Timing (reception at falling edge)



5-2-3 Serial Interface Transfer Timing

Serial interface 0 uses the SC0CE0 and SC0CE1 flags of serial interface 0 mode register 0 (SC0MD0), and serial interface 1 uses the SC1CE0 and SC1CE1 flags of serial interface 1 mode register 0, to control the edge at which transmission data is output and the edge at which reception data is input.

During transmission, when the SCnCE1 flag is "0," data output is synchronized to the falling edge of the clock.

During reception, when the SCnCE0 flag is "0," data reception is synchronized to the opposite polarity edge of the transmit data edge. When the SCnCE0 flag is "1," data reception is synchronized to the same polarity edge as the transmit data edge.

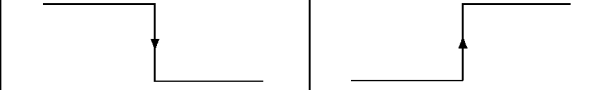
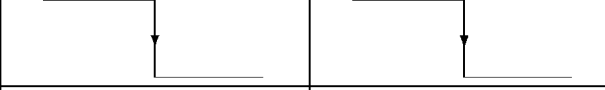
Table 5-2-1 Serial Data Input Edge and Output Edge (serial interface 0, 1)

SC0CE0	SC0CE1	Receive Data Input Edge	Transmit Data Output Edge
0	0		
0	1		
1	0		
1	1		

Serial interface 2 uses the SC2CE0 flag of the serial interface 2 mode register 0 to control the edge at which reception data is input.

During transmission, data is output in synchronization with the falling edge of the clock.

During reception, when the SC2CE0 flag is "0", data is input in synchronization with the rising edge of the clock. When the SC2CE0 flag is "1", data is input in synchronization with the falling edge of the clock.

Table 5-2-2 Serial Data Input Edge and Output Edge (serial interface 2)

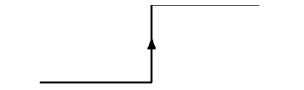
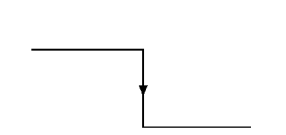
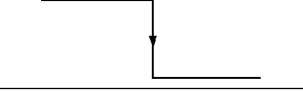
SC2CE0	Receive Data Input Edge	Transmit Data Output Edge
0		
1		

When serial interface 0 and/or serial interface 1 are used for simultaneous transmission and reception, set the SCnCE0 and SCnCE1 flags of the SCnMD0 register to "00" or "01", so that the reception data input edge is opposite in polarity to the transmit data output edge. Also, the polarity of the reception data input edge is opposite polarity of the transmit data output edge of the other device.

When serial interface 2 is to be used for simultaneous synchronous serial transmission and reception, set the SC2CE0 flag of the SC2MD0 register to "0", so that the receive data input edge is opposite in polarity to the transmit data output edge. Also, set the transmit data output edge of the other device to the falling edge of the clock.

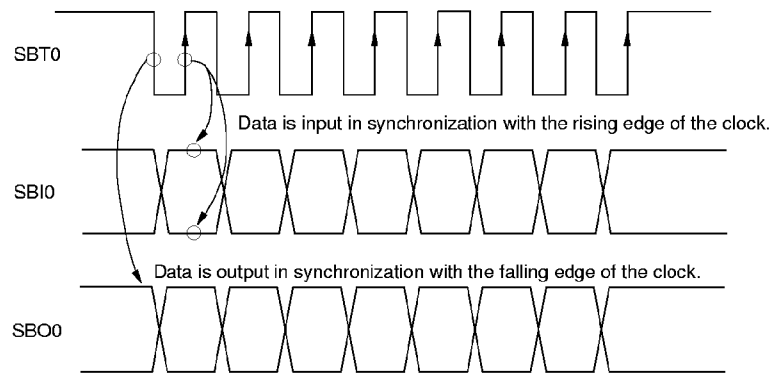

Figure 5-2-5 Synchronous Serial Transmit/Receive Timing
(data is received at the rising edge and transmitted at the falling edge)

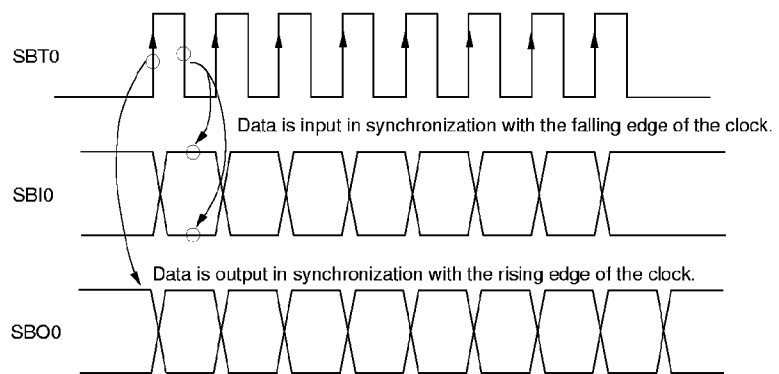

Figure 5-2-6 Synchronous Serial Transmit/Receive Timing
(data is received at the falling edge and transmitted at the rising edge)

5-3 Simple UART Serial Interface

5-3-1 Overview

Setup and operation of UART transmission and reception are described below.

5-3-2 Setup and Operation

■ Transmission

- (1) Select UART by setting the SC0CMD flag of the serial interface 0 control register (SC0CTR) to "1."
- (2) Specify the first bit to be transferred (MSB first or LSB first) with the SCODIR flag of the serial interface 0 mode register 0 (SC0MD0).
- (3) Select the valid edge of the clock signal with the SC0CE1~0 flags of the SC0MD0 register.
- (4) Select the clock source with the SC0CK1~0 flags of serial interface 0 mode register 1 (SC0MD1).
- (5) Set the SC0CKM flag of the SC0MD1 register to "1" to divide the clock source frequency by 8.
- (6) Set the SC0NPE flag of the serial interface 0 mode register 2 (SC0MD2) to enable or disable parity.
- (7) If parity is enabled by the SC0NPE flag of the SC0MD2 register, set the SC0PM1~0 flags of the SC0MD2 register to specify the added parity bit.

When the serial port is enabled and the SC0CE1~0 flags of the SC0MD0 register are toggled, the transfer bit count may change.

The TXD pin goes to a high level after transmission is complete.



Setting the SC0FM flag of the SC0MD2 register to frame mode automatically sets the SC0LNG2~0 flags of the SC0MD0 register.



After the transfer is complete, the SC0LNG2~0 flags of the SC0MD0 register are automatically set with the transfer bit count.

Serial interface 0 begins operation when the SC0SBOS flag or the SC0SBIS flag is set to "1." Set the SC0SBOS flag or the SC0SBIS flag after all conditions have been set.

- (8) Set the SC0FM1~0 flags of the SC0MD2 register to specify the frame mode.
- (9) Set the SC0BRKE flag of the SC0MD2 register to control break status transmission.
- (10) Select the SC0SBOM flag of the SC0MD3 register.
- (11) Select the SC0IOM flag of the SC0MD3 register.
- (12) Set bit 0 of the port 0 direction control register (PODIR) to the output mode.
- (13) Select serial communication by setting the SC0SBOS flag of the SC0MD3 register to "1."
- (14) Set transmit data to serial interface 0 transmit/receive shift register (SC0TRB). This will start the serial transmission.
- (15) When the serial transmission begins, the SC0BSY flag of the SC0CTR register is set to "1," indicating that a serial transfer is in progress.
- (16) When the serial transmission is complete, the SC0BSY flag of the SC0CTR register is cleared to "0" and the SC0 transfer complete interrupt request flag is set to "1." The SC0TRI flag of the SC0MD1 register is cleared to "0."

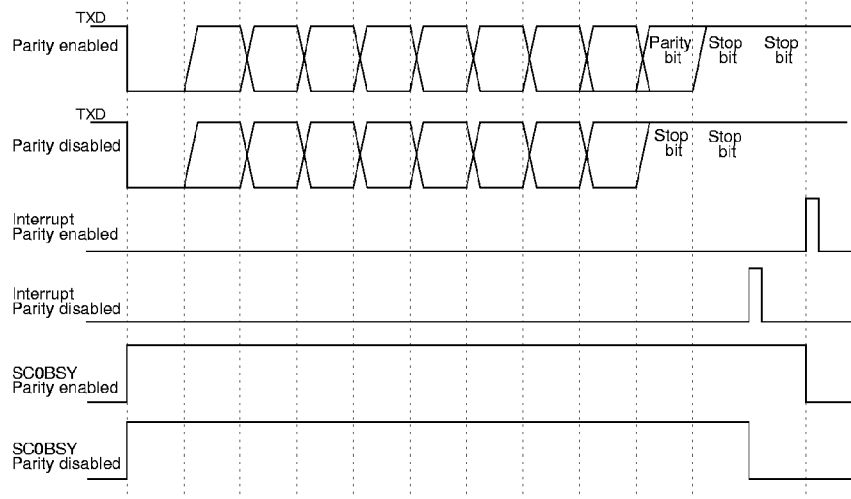

Figure 5-3-1 UART Transmission Timing

■ Reception

- (1) Select UART by setting the SCOCMD flag of the serial interface 0 control register (SCOCTR) to "1."
- (2) Specify the first bit to be transferred (MSB first or LSB first) with the SCODIR flag of the serial interface 0 mode register 0 (SCOMD0).
- (3) Select the valid edge of the clock signal with the SCOCE1~0 flags of the SCOMD0 register.
- (4) Select the clock source with the SCOCK1~0 flags of serial interface 0 mode register 1 (SCOMD1).
- (5) Set the SCOCKM flag of the SCOMD1 register to "1" to divide the clock source frequency by 8.
- (6) Set the SCONPE flag of the serial interface 0 mode register 2 (SCOMD2) to enable or disable parity.
- (7) If parity is enabled by the SCONPE flag of the SCOMD2 register, set the SCOPM1~0 flags of the SCOMD2 register to specify the added parity bit.
- (8) Set the SCOFM1~0 flags of the SCOMD2 register to specify the frame mode.
- (9) Select the SCOIOM flag of the SCOMD3 register.
- (10) When the SCOIOM flag of the SCOMD3 register is specified that the pin is independent, set bit 1 of the port 0 direction control register (PODIR) to the input mode.
- (11) Set bit 0 of the port 0 pull-up resistor control register (POPIU).
- (12) Select serial communication by setting the SCOSBIS flag of the SCOMD3 register to "1."
- (13) When the serial transmission begins, the SCOBSY flag of the SCOCTR register is set to "1," indicating that a serial transfer is in progress.
- (14) When the serial transmission is complete, the SCOBSY flag of the SCOCTR register is cleared to "0" and the SC0 transfer complete interrupt request flag is set to "1." The SCOTRI flag of the SCOMD1 register is cleared to "1."

When the serial port is enabled and the SCOCE1~0 flags of the SCOMD0 register are toggled, the transfer bit count may change.

The TXD pin goes to a high level after reception is complete.

Serial interface 0 begins operation when the SCOSBOS or SCOSBIS flag is set to "1." Set the SCOSBOS or SCOSBIS flag after all conditions have been set.

One machine cycle after the stop bit has been received, the start condition will no longer be accepted. Therefore, consecutive reception must be performed carefully.



Setting the SCOFM flag of the SCOMD2 register to frame mode automatically sets the SCOLNG2~0 flags of the SCOMD0 register.



After the transfer is complete, the SCOLNG2~0 flags of the SCOMD0 register are automatically set with the transfer bit count.

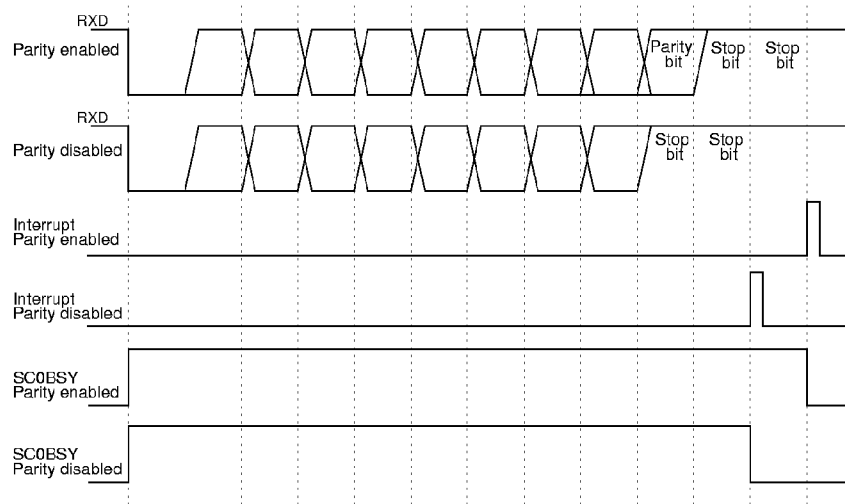

Figure 5-3-2 UART Reception Timing

5-3-3 How to Use the Baud Rate Timer

Refer to the following when using the baud rate timer to set the UART transfer speed.

- (1) Specifying the timer clock source

The clock source is specified by the TM3CK3~1 flags of the timer 3 mode register (TM3MD).

- (2) Setting the compare register

The compare register value is set in the timer 3 compare register (TM3OC).

This set value is computed according to the following formula:

$$\text{overflow period} = (\text{compare register set value} + 1) \times \text{timer clock period}$$

$$\text{baud rate} = 1/(\text{overflow period} \times 2 \times 8)$$

$$\uparrow \text{SC0MD1(SC0CKM)}$$

$$\text{compare register set value} = \text{timer clock frequency}/(\text{baud rate} \times 2 \times 8) - 1$$

Table 5-3-1 UART Transfer Rate

Transfer Speed fosc (MHz)	Transfer Speed (bps)	300		1200		2400		4800		9600		19200	
		Set Value	Calculated Value	Set Value	Calculated Value	Set Value	Calculated Value	Set Value	Calculated Value	Set Value	Calculated Value	Set Value	Calculated Value
4.0	fosc	—	—	208	1202	104	2403	52	4807	26	9615	13	19230
	fs/4	104	300	—	—	—	—	—	—	—	—	—	—
	fs/16	—	—	—	—	—	—	—	—	—	—	—	—
4.19	fosc	—	—	218	1201	109	2402	55	4761	27	9699	—	—
	fs/4	109	300	—	—	—	—	—	—	—	—	—	—
	fs/16	—	—	—	—	—	—	—	—	—	—	—	—
8.0	fosc	—	—	—	—	208	2404	104	4807	52	9615	26	19230
	fs/4	208	300	52	1201	—	—	—	—	—	—	—	—
	fs/16	—	—	—	—	—	—	—	—	—	—	—	—
8.38	fosc	—	—	—	—	218	2403	109	4805	55	9523	27	19398
	fs/4	218	300	55	1190	—	—	—	—	—	—	—	—
	fs/16	—	—	—	—	—	—	—	—	—	—	—	—
12.0	fosc	—	—	—	—	—	—	156	4808	78	9615	39	19230
	fs/4	—	—	78	1202	39	2403	—	—	—	—	—	—
	fs/16	78	300	—	—	—	—	—	—	—	—	—	—
16.0	fosc	—	—	—	—	—	—	208	4808	104	9615	52	19230
	fs/4	—	—	104	1202	52	2404	—	—	—	—	—	—
	fs/16	104	300	—	—	—	—	—	—	—	—	—	—
16.76	fosc	—	—	—	—	—	—	218	4805	109	9610	55	19045
	fs/4	—	—	109	1201	55	2381	—	—	—	—	—	—
	fs/16	109	300	—	—	—	—	—	—	—	—	—	—
20.0	fosc	—	—	—	—	—	—	—	—	130	9615	65	19231
	fs/4	—	—	130	1202	65	2404	33	4735	—	—	—	—
	fs/16	130	300	—	—	—	—	—	—	—	—	—	—

Set the values from this table (minus 1) in the compare register.

Example:

The timer 3 clock source is fs/4 (fosc = 8MHz) and a baud rate of 300 bps is desired.

Since fs=fosc/2,

$$\text{compare register set value} = (8 \times 10^6/2/4)/(300 \times 2 \times 8) - 1$$

$$=207$$

$$= \text{X'CF'}$$

5-4 Simple IIC Serial Interface

5-4-1 Overview

The simple IIC serial interface is a single master bus. Several devices may be connected as slaves.

5-4-2 Setup and Operating Procedure

■ Transmission (1-byte transmission, then transmission of n-bytes)

Set the CLKPOL2 flag of the SC2MD0 register to "1" before setting the SC2LNG3~0 flags of the SC2MD0 register.

- (1) Set bit 2 of port 3.
 - Set bit 2 of the port 3 output register (P3OUT) to "1" ("H" level).
 - Set bit 2 of the port 3 direction control register (P3DIR) to "1" (output mode).
- (2) Set bit 0 of port 3.
 - Set bit 0 of the P3OUT register to "1" ("H" level).
 - Set bit 0 of the P3DIR register to "1" (output mode).
- (3) Set bit 0 of the port 3 output register (P3OUT) to "0" ("L" level) to output the start condition.
- (4) Set the SC2MD0 register.
 - Set the SC2CMD flag of the SC2MD0 register to "1" (IIC mode).
 - Set the SC2LNG3~0 flags of the SC2MD0 register to specify the transfer bit count as 9 bits.
 - Set the SC2STE flag of the SC2MD0 register to disable the start condition.
 - Set the SC2DIR flag of the SC2MD0 register to MSB first.
 - Set the SC2CE0 flag of the SC2MD0 register so that reception data is input on the falling edge.
- (5) Set the SC2MD1 register.
 - Set the SC2CK2~0 flags of the SC2MD1 register to specify the clock source as 1/2 of the overflow of timer 0.
 - Set the SC2SBTS flag of the SC2MD1 register to "1" (serial clock pin).
 - Set the SC2SBTM flag of the SC2MD1 register.
 - Set the SC2SBOM flag of the SC2MD1 register.
- (6) Set the SC2CTR register.
 - Set the SC2ACKO flag of the SC2CTR register to "1" ("H" level). (During transmission, the output level is the same as the 9th bit of data (the ACK bit)).
 - Set the SC2ACKS flag of the SC2CTR register to "1" to enable the ACK bit.
 - Set the SC2SBOM flag of the SC2CTR register to "1" (connected).

The SC2SPKF, SC2STKF, SC2SPEN, and SC2STEN flags of the SC2CTR register are normally set to "0".

- (7) Set the SIFOEO2 and SIFOEI2 flags of the SC2MD1 register to "1" to enable the serial port.
- (8) Write data to the serial interface 2 transmit/receive shift register (SC2TRB) to start the serial transmission.
- (9) When the transmission of 9-bit data (8 data bits + ACK bit) is complete, the SC2 transfer complete interrupt will be received.
- (10) Read the SIFACK flag of the SC2CTR register and determine the value of the ACK bit.
If the transmission is complete, go to (13).
If the transmission is continuing, go to (11).
- (11) Set the SC2MD0 register.
 - Set the SC2LNG3~0 flags of the SC2MD0 register to specify the transfer bit count as 9 bits.
- (12) Set the SC2CTR register.
 - Set the SC2ACKO flag of the SC2CTR register to "1" ("H" level). (During transmission, the output level is the same as the 9th bit of data (the ACK bit)).
Repeat processing from step (8).
- (13) Set bit 2 and bit 0 of the P3OUT register to "0".
- (14) Set the SC2SBOS, SC2SBIS, SC2SBTS flags of the SC2MD1 register to "0".
(Switch the SBT2 and SBO2 pins to function as ports.)
- (15) Set bit 2 of the P3OUT register to "1".
- (16) Set bit 0 of the P3OUT register to "1".

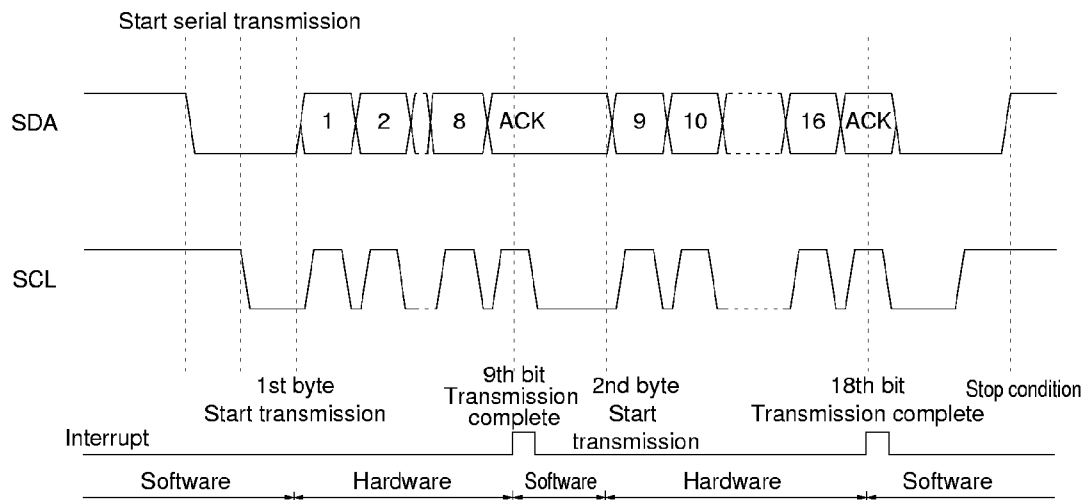

Figure 5-4-1 Master Transmission

■ Reception (1-byte transmission, then reception of n-bytes)

- (1) Set bit 2 of port 3.
 - Set bit 2 of the port 3 output register (P3OUT) to "1" ("H" level).
 - Set bit 2 of the port 3 direction control register (P3DIR) to "1" (output mode).
- (2) Set bit 0 of port 3.
 - Set bit 0 of the P3OUT register to "1" ("H" level).
 - Set bit 0 of the P3DIR register to "1" (output mode).
- (3) Set bit 0 of the port 3 output register (P3OUT) to "0" ("L" level) to output the start condition.
- (4) Set the SC2MD0 register.
 - Set the SC2CMD flag of the SC2MD0 register to "1" (IIC mode).
 - Set the SC2LNG3~0 flags of the SC2MD0 register to specify the transfer bit count as 9 bits.
 - Set the SC2STE flag of the SC2MD0 register to disable the start condition.
 - Set the SC2DIR flag of the SC2MD0 register to MSB first.
 - Set the SC2CE0 flag of the SC2MD0 register so that reception data is input on the falling edge.
- (5) Set the SC2MD1 register.
 - Set the SC2CK2~0 flags of the SC2MD1 register to specify the clock source as 1/2 of the overflow of timer 0.
 - Set the SC2SB1S flag of the SC2MD1 register to "1" (serial clock pin).
 - Set the SC2SBTM flag of the SC2MD1 register.
 - Set the SC2SBOM flag of the SC2MD1 register.
- (6) Set the SC2CTR register.
 - Set the SC2ACKO flag of the SC2CTR register to "1" ("H" level). (During transmission, the output level is the same as the 9th bit of data (the ACK bit)).
 - Set the SC2ACKS flag of the SC2CTR register to "1" to enable the ACK bit.
 - Set the SC2SBOM flag of the SC2CTR register to "1" (connected).
- (7) Set the SC2SBOS and SC2SBIS flags of the SC2MD1 register to "1" to enable the serial port.
- (8) Write data to the serial interface 2 transmit/receive shift register (SC2TRB) to start the serial transmission.
- (9) When the transmission of 9-bit data (8 data bits + ACK bit) is complete, an SC2 transfer complete interrupt will be received.
- (10) Read the SIFACK flag of the SC2CTR register and determine the value of the ACK bit.

Set the SC2CMD flag of the SC2MD0 register to "1" before setting the SC2LNG3~0 flags of the SC2MD0 register.

The SC2SPKF, SC2STKF, SC2SPEN, and SC2STEN flags of the SC2CTR register are normally set to "0".

The reception process is described in the following steps.

- (11) Set the SC2MD0 register.
 - Set the SC2LNG3~0 flags of the SC2MD0 register to specify the transfer bit count as 8 bits.
- (12) Set bit 0 of the P3DIR register to "0" (input mode).
- (13) Write dummy data to the serial interface 2 transmit/receive shift register (SC2TRB) to start the serial reception.
- (14) When the reception of 8-bit data is complete, the SC2 transfer complete interrupt will be received. The 8-bit received data is input to the serial interface 2 transmit/receive shift register (SC2TRB).

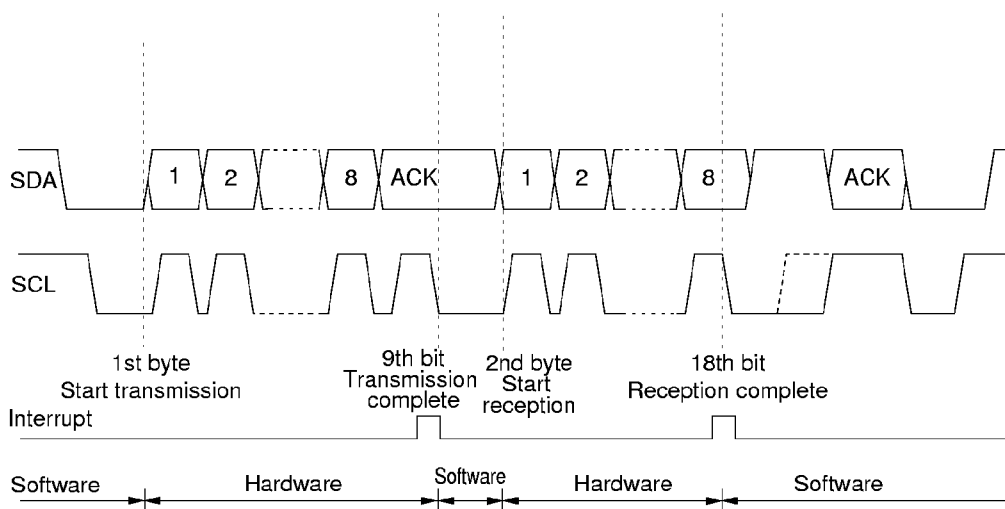

Figure 5-4-2 Master Reception

Control and processing of the ACK bit are described in steps (15)~(19) below.

- (15) Set bit 2 of the P3OUT register to "0".
- (16) Set the SC2SBOS, SC2SBIS, SC2SBTS flags of the SC2MD1 register to "0".
(Switch the SBT2 and SBO2 pins to function as ports.)
- (17) Set bit 2 of the P3OUT register to "1".
- (18) Set bit 0 of the P3OUT register to "0". (In the case of NACK, set to "1").
- (19) Set bit 0 of the P3DIR register to "1" (output mode).
If the reception is complete, go to (23).
If the reception is continuing, go to (20).
- (20) Set the SC2MD0 register.
 - Set the SC2BC03~0 flags of the SC2MD0 register to specify the transfer bit count as 8 bits.
- (21) Set the SC2SBTS flag of the SC2MD1 register to "1". (Switch the SBT2 pin to a serial clock pin).
- (22) Set the SC2SBOS and SC2SBIS flags of the SC2MD1 register to "0". (Switch the SBO2 pin to serial).
Repeat processing from step (13).
- (23) Set bit 2 and bit 0 of the P3OUT register to "0".
- (24) Set the SC2SBOS, SC2SBIS and SC2SBTS flags of the SC2MD1 register to "0". (Switch the SBT2 and SBO2 pins to function as ports.)
- (25) Set bit 2 of the P3OUT register to "1".
- (26) Set bit 0 of the P3OUT register to "1".

The SC2SBTS flags of the SC2MD1 register must be set to "1" before setting the SC2SBOS and SC2SBIS flags of the SC2MD1 register to "1".

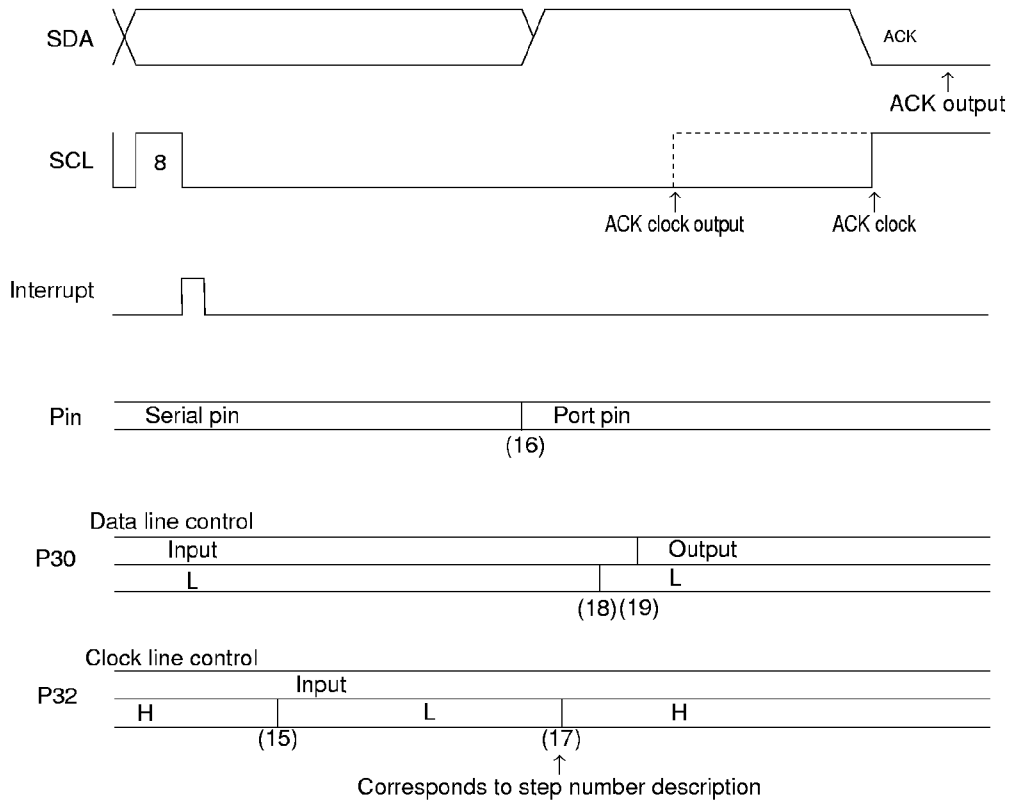

Figure 5-4-3 ACK Processing during Reception

5-5 Serial Interface Control Registers

5-5-1 Overview

Fourteen registers control the serial interface. See table 5-5-1.

Table 5-5-1 Serial Interface Registers

Name	Address	R/W	Function
SC0MD0	X'03F50'	R/W	Serial interface 0 mode register 0
SC0MD1	X'03F51'	R/W	Serial interface 0 mode register 1
SC0MD2	X'03F52'	R/W	Serial interface 0 mode register 2
SC0MD3	X'03F53'	R/W	Serial interface 0 mode register 3
SC1MD0	X'03F57'	R/W	Serial interface 1 mode register 0
SC1MD1	X'03F58'	R/W	Serial interface 1 mode register 1
SC2MD0	X'03F5A'	R/W	Serial interface 2 mode register 0
SC2MD1	X'03F5B'	R/W	Serial interface 2 mode register 1
SC0CTR	X'03F54'	R/W	Serial interface 0 control register
SC2CTR	X'03F5C'	R/W	Serial interface 2 control register
SC0TRB	X'03F55'	W	Serial interface 0 transmit/receive shift register
SC0RXB	X'03F56'	R	Serial interface 0 receive data buffer
SC1TRB	X'03F59'	R/W	Serial interface 1 transmit/receive shift register
SC2TRB	X'03F5D'	R/W	Serial interface 2 transmit/receive shift register

5-5-2 Transmit/Receive Shift Registers, Receive Data Buffer

(1) Serial interface 0 transmit/receive shift register (SC0TRB)

This 8-bit, writable register shifts the transmission data and the reception data. The direction of transfer can be specified as LSB first or MSB first.

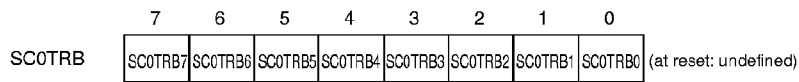

Figure 5-5-1 Serial Interface 0 Transmit/Receive Shift Register
(SC0TRB: X'03F55', W)

(2) Serial interface 0 received data buffer (SC0RXB)

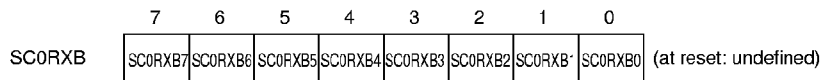

Figure 5-5-2 Serial Interface 0 Receive Data Buffer
(SC0RXB: X'03F56', R)

(3) Serial interface 1 transmit/receive shift register (SC1TRB)

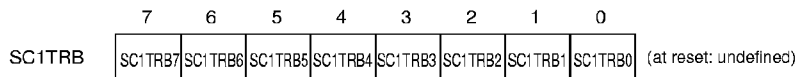

Figure 5-5-3 Serial Interface 1 Transmit/Receive Shift Register
(SC1TRB: X'03F59', R/W)

(3) Serial interface 2 transmit/receive shift register (SC2TRB)

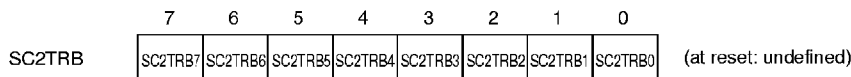

Figure 5-5-4 Serial Interface 2 Transmit/Receive Shift Register
(SC2TRB: X'03F5D', R/W)

5-5-3 Serial Interface Mode Registers

(1) Serial interface 0 mode register (SC0MD0)

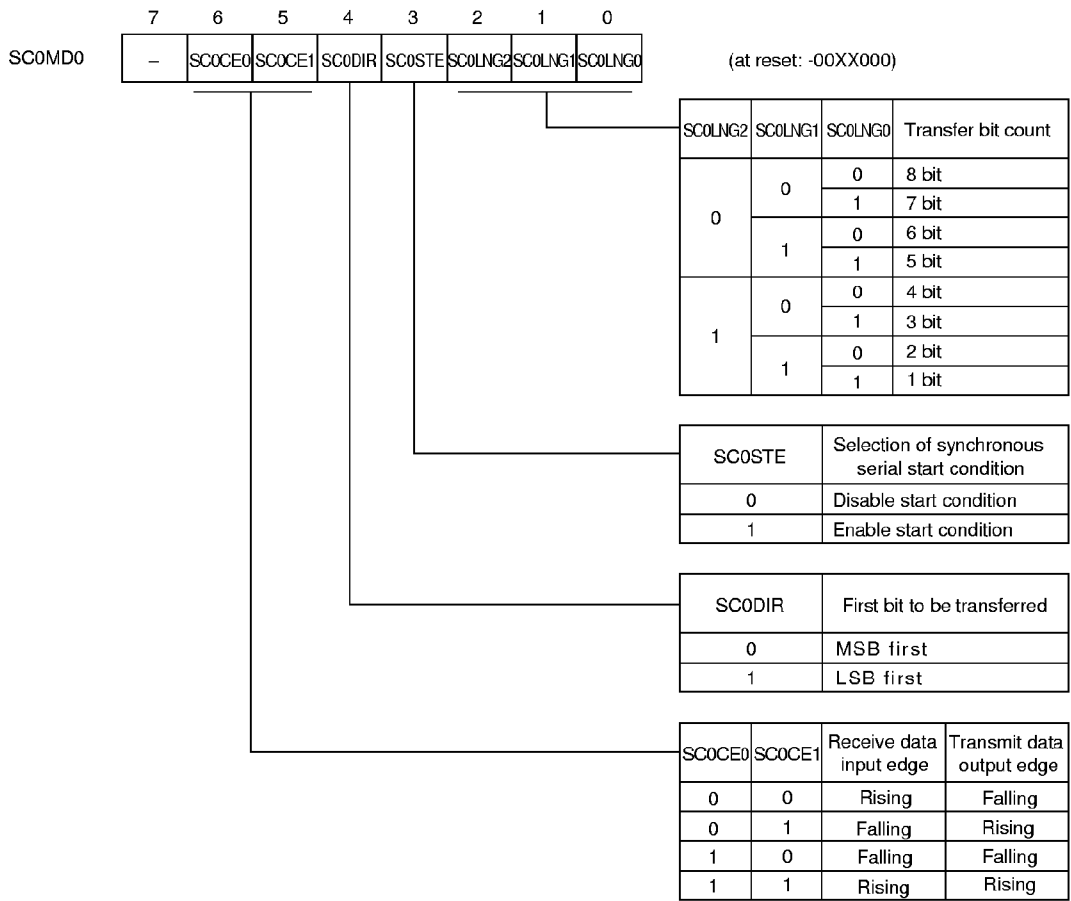

Figure 5-5-5 Serial Interface 0 Mode Register 0 (SC0MD0: X'03F50', R/W)

(2) Serial interface 0 mode register 1 (SC0MD1)

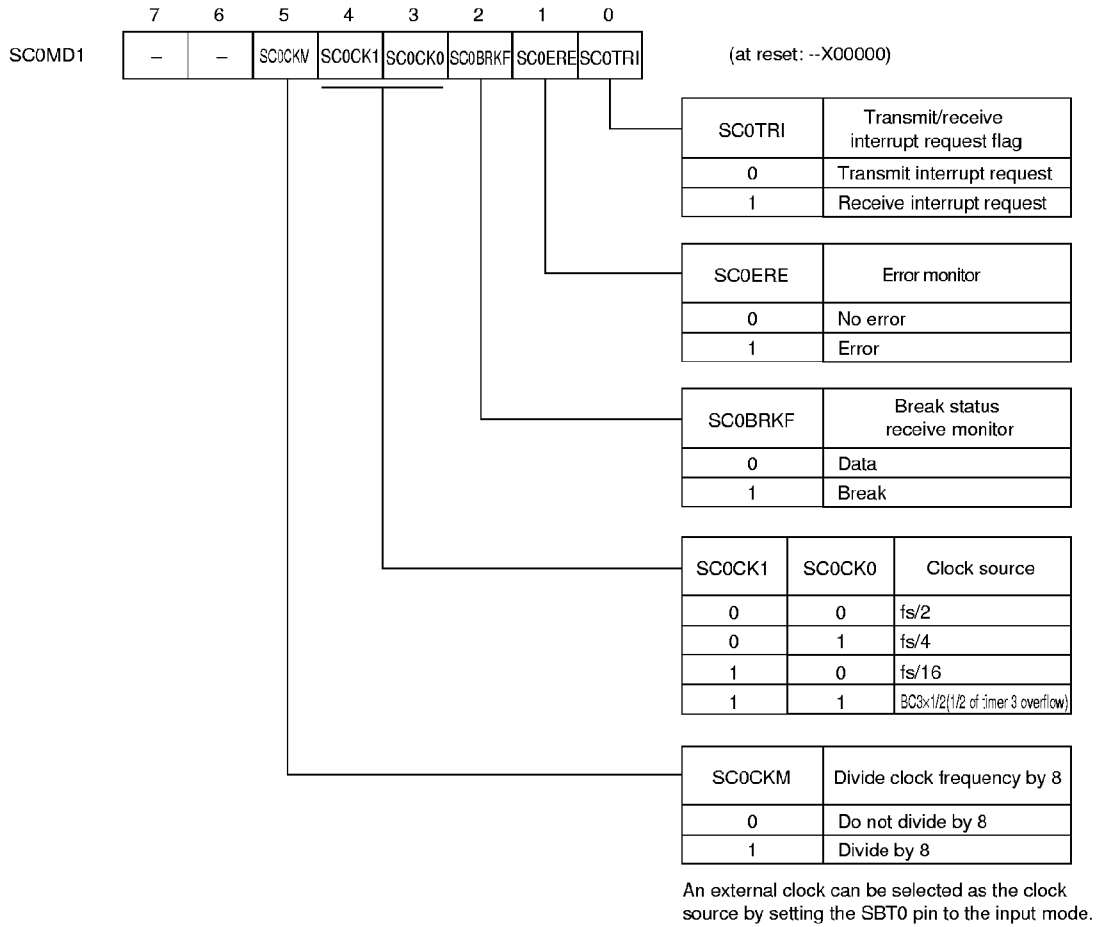

Figure 5-5-6 Serial Interface 0 Mode Register 1 (SC0MD1: X'03F51', R/W)

(3) Serial interface 0 mode register 2 (SC0MD2)

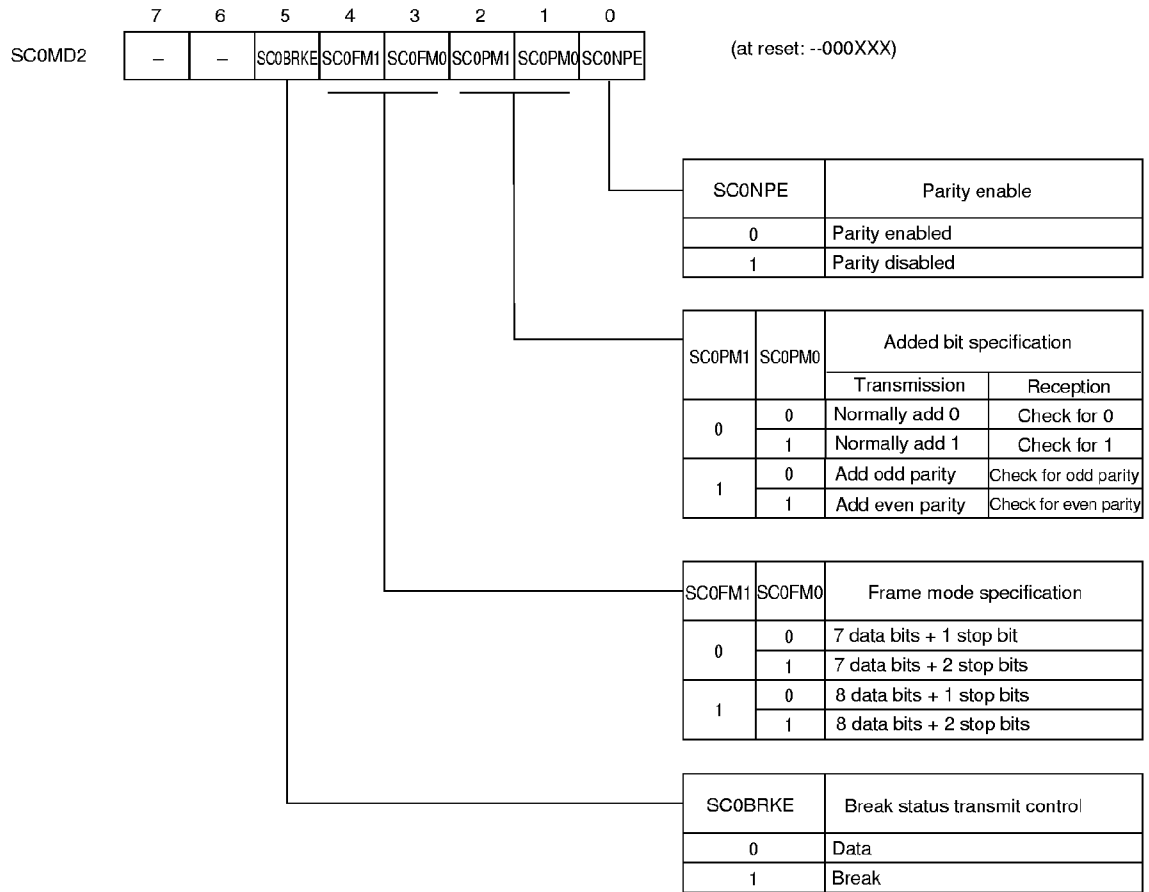

Figure 5-5-7 Serial Interface 0 Mode Register 2 (SC0MD2: X'03F52', R/W)

(4) Serial interface 0 mode register 3 (SC0MD3)

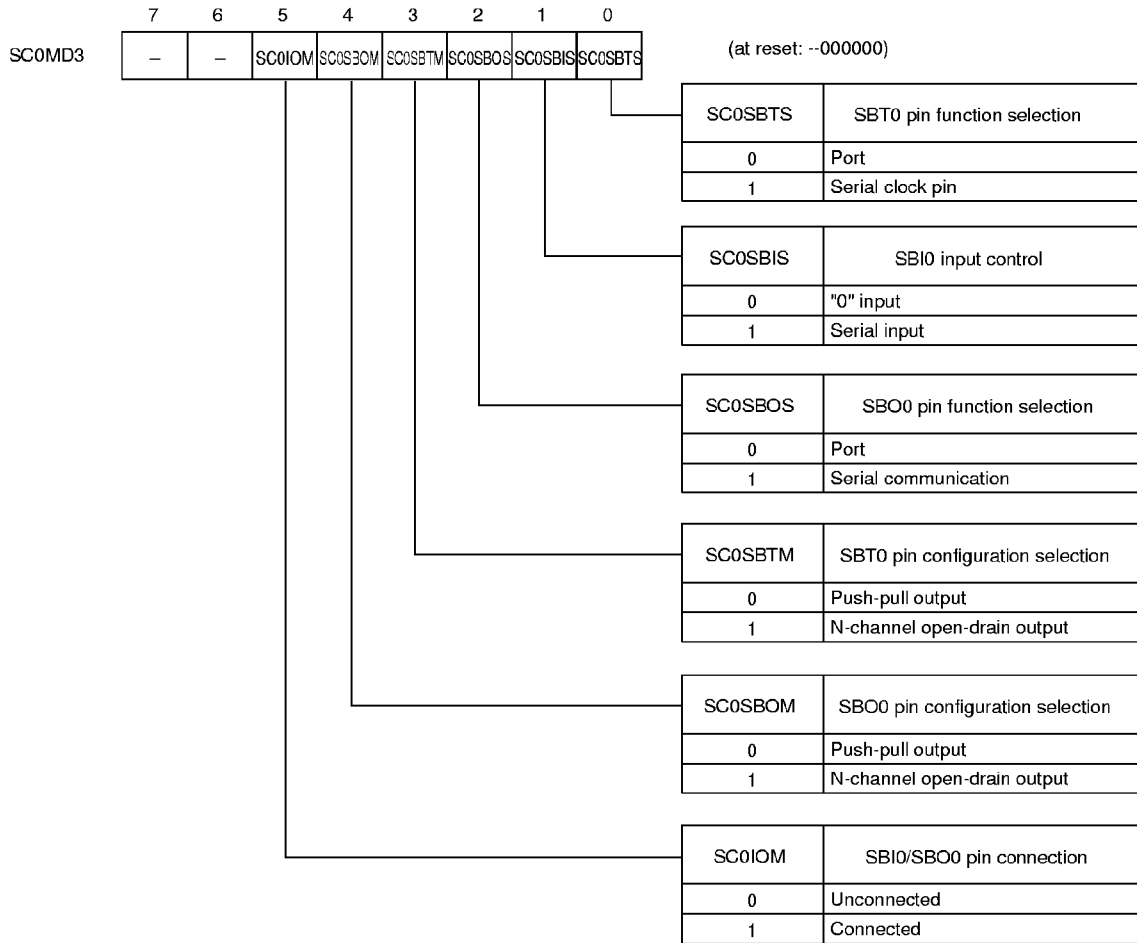

Figure 5-5-8 Serial Interface 0 Mode Register 3 (SC0MD3: X'03F53', R/W)

(5) Serial interface 1 mode register 0 (SC1MD0)

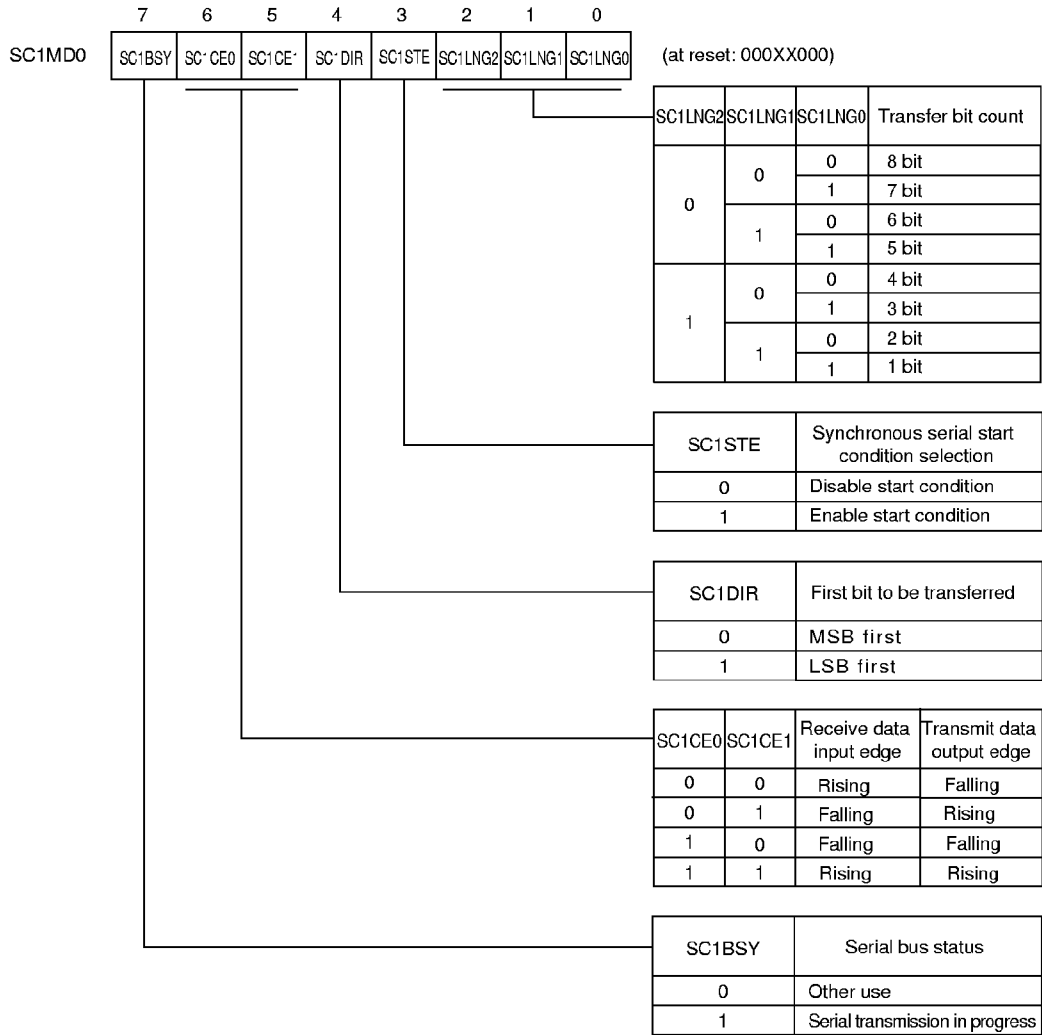

Figure 5-5-9 Serial Interface 1 Mode Register 0 (SC1MD0: X'03F57', R/W)

(6) Serial interface 1 mode register 1 (SC1MD1)

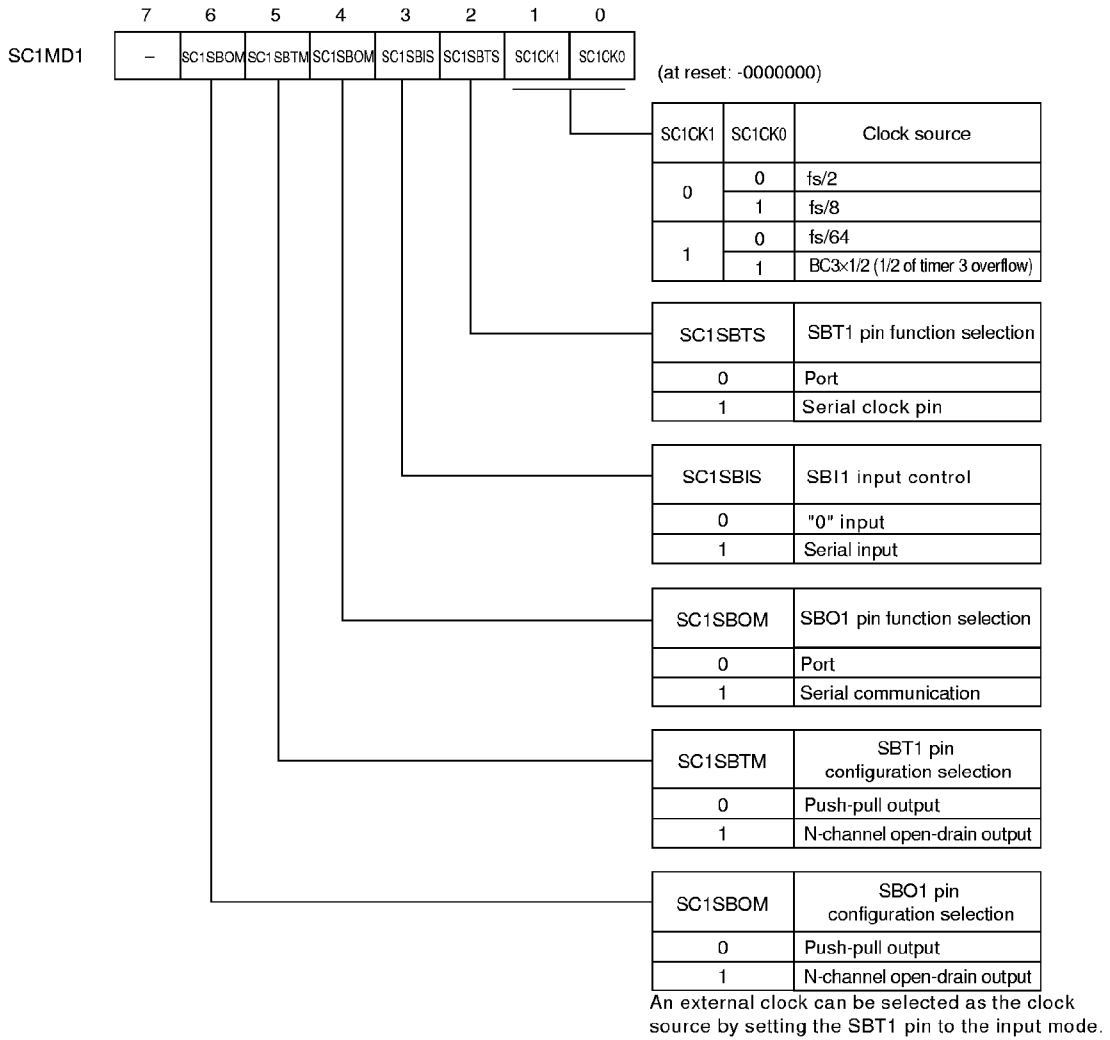

Figure 5-5-10 Serial Interface 1 Mode Register 1 (SC1MD1: X'03F58', R/W)

(7) Serial interface 2 mode register 0 (SC2MD0)

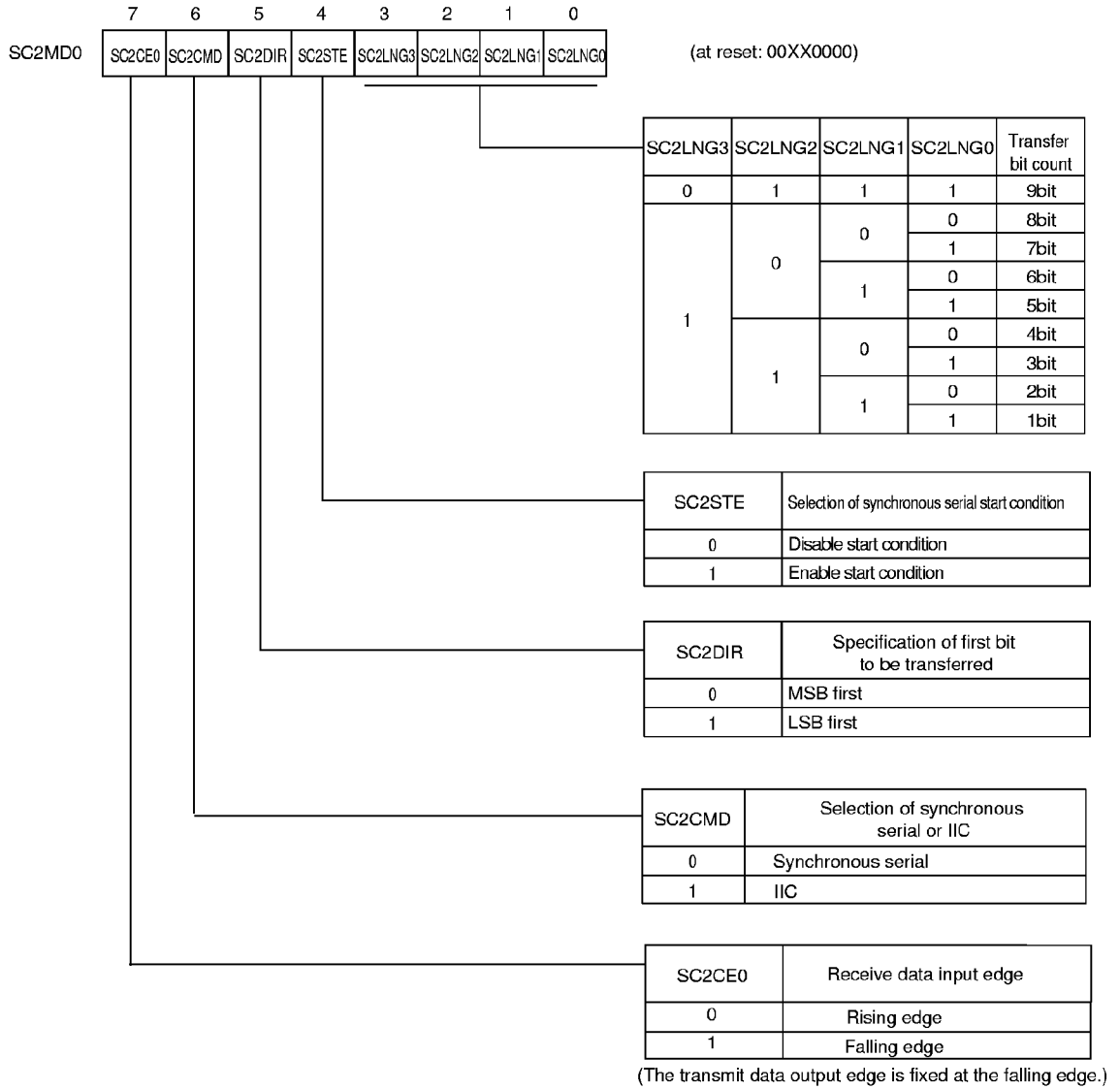

Figure 5-5-11 Serial Interface 2 Mode Register 0 (SC2MD0: X'03F5A', R/W)

(8) Serial interface 2 mode register 1 (SC2MD1)

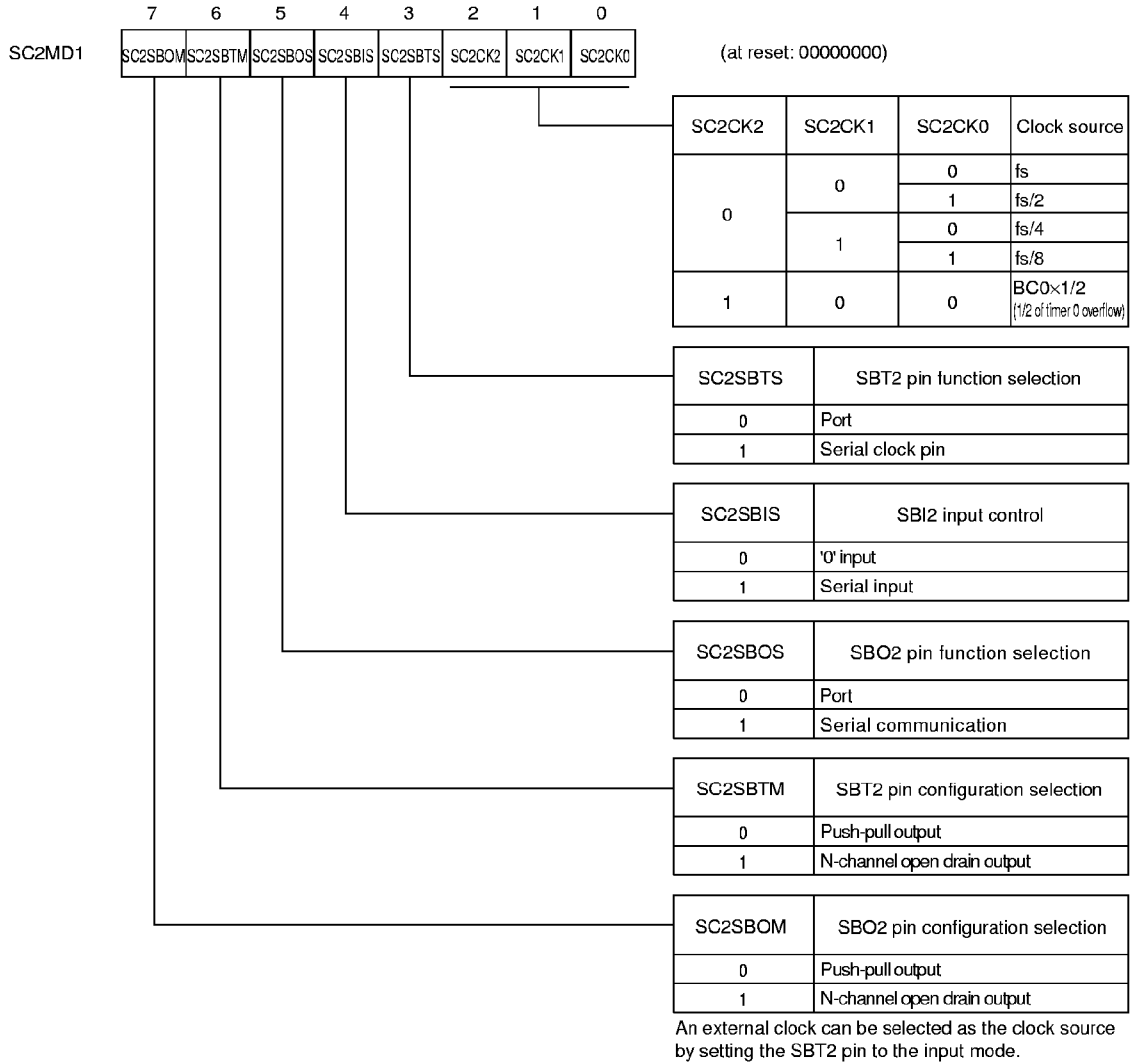

Figure 5-5-12 Serial Interface 2 Mode Register 1 (SC2MD1: X'03F5B', R/W)

5-5-4 Serial Interface Control Register

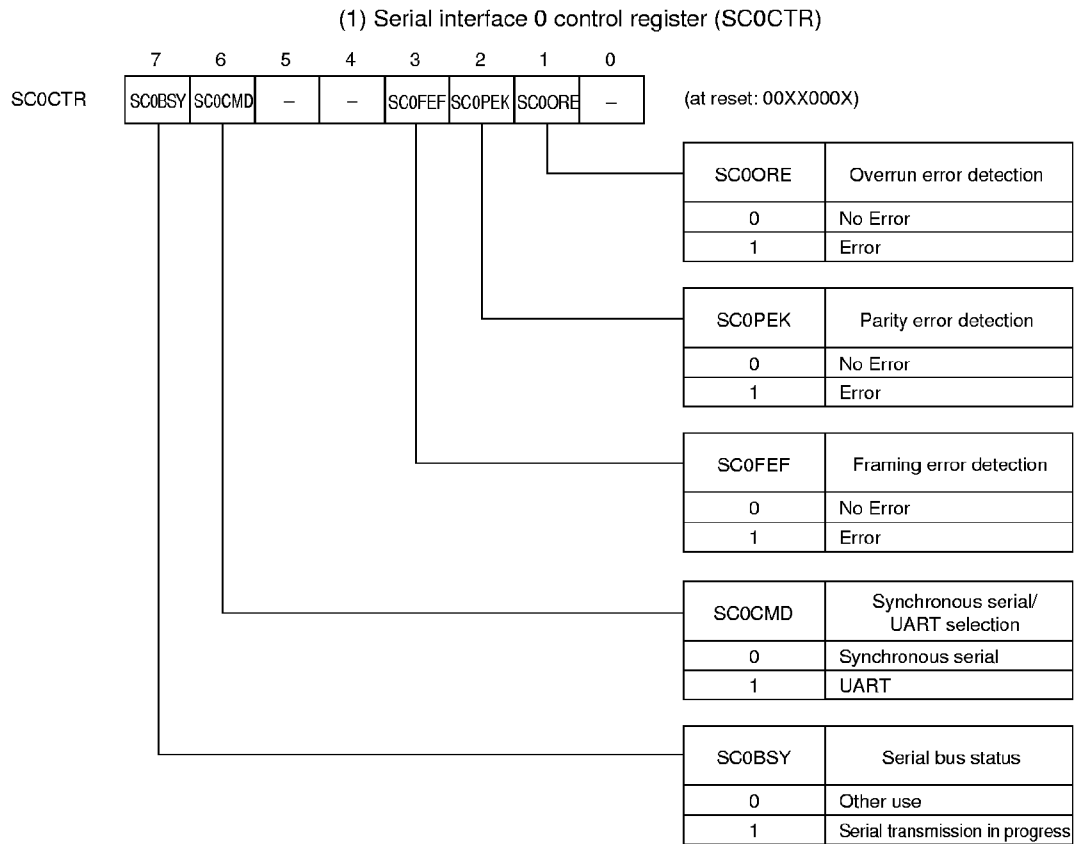

Figure 5-5-13 Serial Interface 0 Control Register (SC0CTR: X'03F54', R/W)

(2) Serial interface 2 control register (SC2CTR)

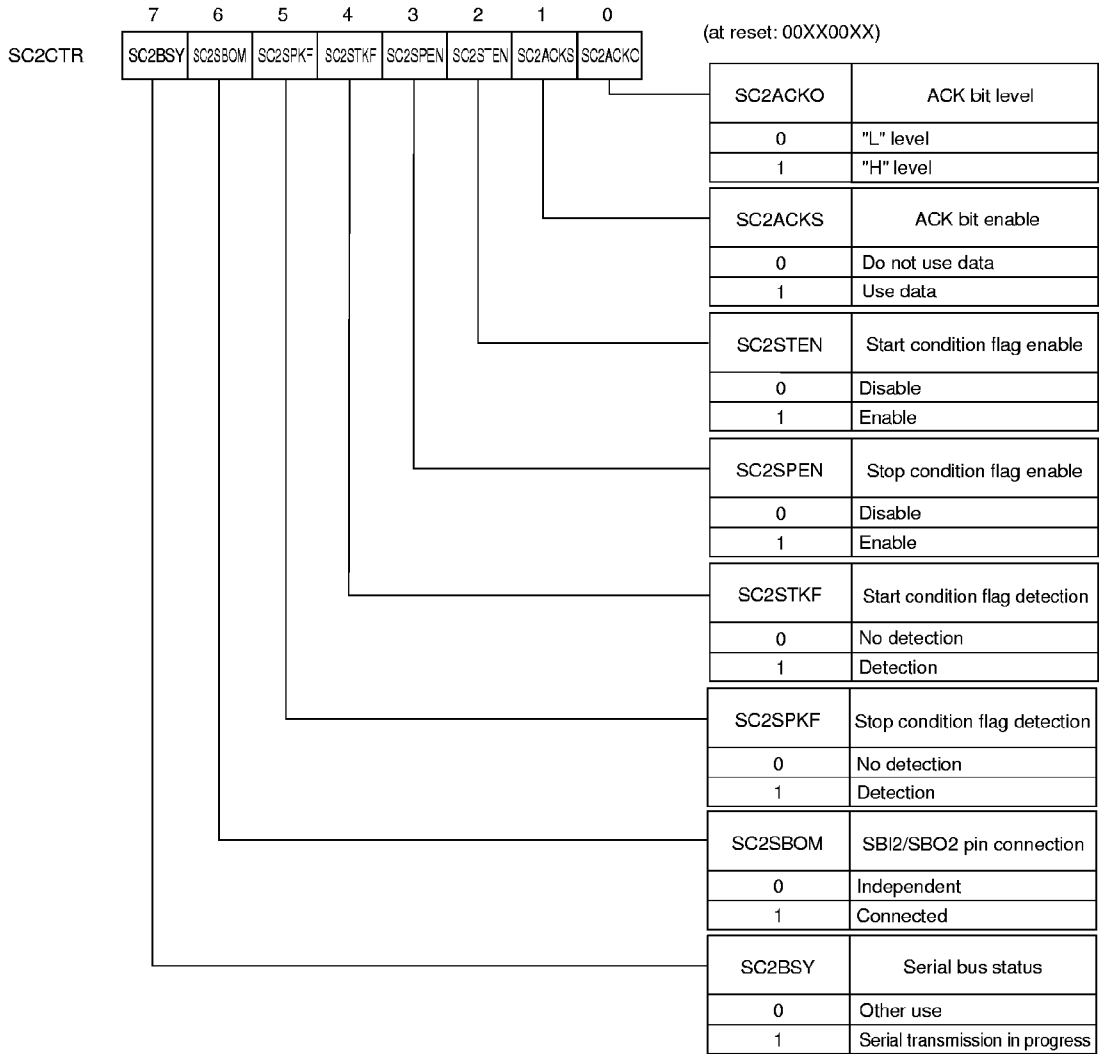

Figure 5-5-14 Serial Interface 2 Control Register (SC2CTR: X'03F5C', R/W)

Chapter 6

A/D Conversion
Functions



6-1 Overview

The MN101C01D has an internal A/D converter with 10-bit resolution. A sample-and-hold circuit is contained on-chip and software can switch the analog input between channels 0~7 (AN0~AN7).

When the A/D converter is stopped, power consumption can be reduced by turning off the internal ladder resistors.

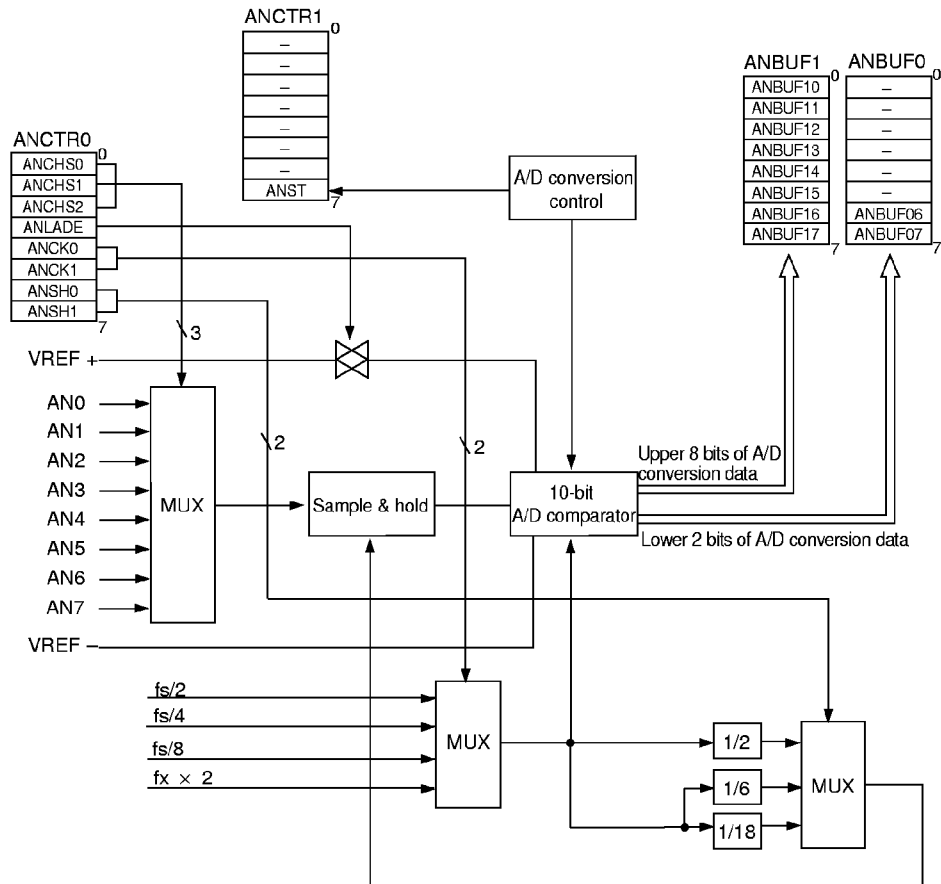

Figure 6-1-1 A/D Converter Block Diagram

6-2 A/D Conversion

The procedures for operating the A/D conversion circuit are listed below.

- (1) Set the ANCIIS2~ANCIIS0 flags of A/D control register 0 (ANCTR0) to specify one of pins AN7~AN0 (PA7~PA0) as the analog input.
- (2) Set the ANCK1 and ANCK0 flags of A/D control register 0 to select the A/D conversion clock. Make this setting such that the period of the conversion clock (T_{AD}), which is based on the oscillator, is greater than 800ns.
- (3) With the ANSH1 and ANSH0 flags of A/D control register 0, set the sample-and-hold time. Select a value for the sample and hold time that is suitable for the analog input impedance.
- (4) Set the ANLADE flag of A/D control register 0 to "1" so that current flows through the ladder resistors and the A/D converter is on standby.
Note: Steps 1~4 above may performed all at the same time.
- (5) Set the ANST flag of A/D control register 1 (ANCTR1) to "1" to start the A/D conversion.
- (6) After the sample-and-hold time set in step 3, the sampled A/D conversion data is sequentially compared to determine its value beginning with the MSB.
- (7) When the A/D conversion is complete, the ANST bit is cleared to "0" and conversion results are stored in A/D buffers (ANBUF0, 1). At the same time, an A/D complete interrupt request (ADIRQ) is generated.

Start the A/D conversion after the current flowing through the ladder resistors stabilizes. The time constant calculated time from the ladder resistance (max. 80 k Ω) and the external bypass capacitor connected between V_{ref+} and V_{ref-} should be used as the criteria for the wait time.

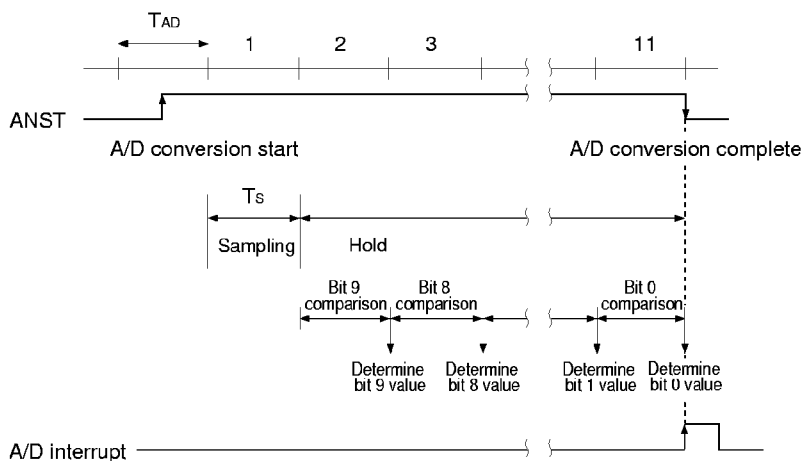
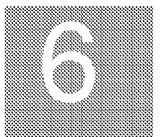

Figure 6-2-1 A/D Conversion Timing



6-3 A/D Converter Control Registers

6-3-1 Overview

Four registers control the A/D converter. See table 6-3-1.

Table 6-3-1 A/D Converter Control Registers

Name	Address	R/W	Function
ANCTR0	X'03F90'	R/W	A/D control register 0
ANCTR1	X'03F91'	R/W	A/D control register 1
ANBUF0	X'03F92'	R	A/D buffer 0
ANBUF1	X'03F93'	R	A/D buffer 1

6-3-2 A/D Control Register (ANCTR)

This readable and writable 8-bit register controls the operation of the A/D converter.

(1) A/D control register 0 (ANCTR0)

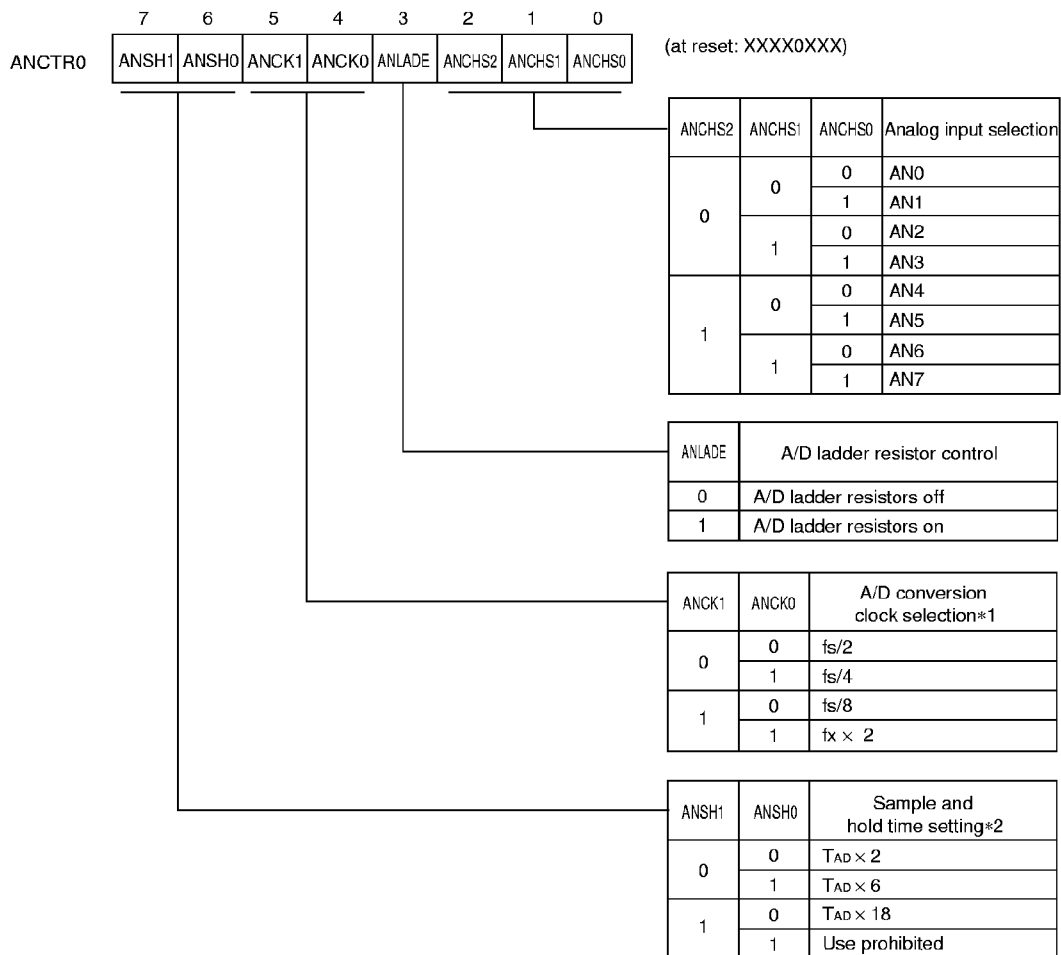

*1: Specify that where the period of the A/D conversion clock is greater than 800ns.

*2: Sample-and-hold time is determined by the analog input impedance. T_{AD} indicates the period of the A/D conversion clock.

Figure 6-3-1 A/D Control Register 0 (ANCTR0: X'03F90', R/W)

(2) A/D conversion control register 1 (ANCTR1)

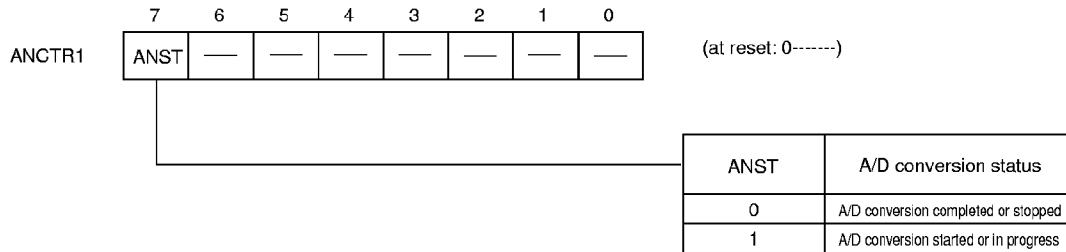

Figure 6-3-2 A/D Control Register 1 (ANCTR1: X'03F91', R/W)

6-3-3 A/D Buffers (ANBUF)

These read-only registers store the A/D conversion results.

(1) A/D buffer 0 (ANBUF0)

This register stores the lower 2 bits of the A/D conversion results.

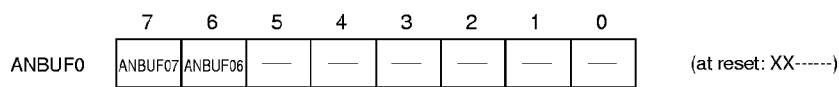

Figure 6-3-3 A/D Buffer 0 (ANBUF0: X'03F92', R)

(2) A/D buffer 1 (ANBUF1)

This register stores the upper 8 bits of the A/D conversion results.

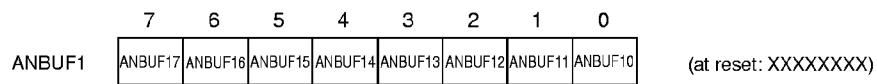

Figure 6-3-4 A/D Buffer 1 (ANBUF1: X'03F93', R)

6-3-4 Warning when Using the A/D Converter



The following items must be implemented to maintain the accuracy of the A/D converter:

1. Use a maximum input pin impedance, R , of $500\text{k}\Omega^{*1}$ with an external capacitor, C , that is minimum $1,000\text{pF}$ and maximum $1\mu\text{F}^{*1}$.
2. Take the RC time into consideration when setting the A/D conversion interval.
3. Changing the output level of the microcomputer or switching peripheral circuitry on or off when the A/D converter is in use may cause the analog input pin or current pin to fluctuate resulting in a loss of precision. During setup and evaluation, verify the waveform of the analog input pin.

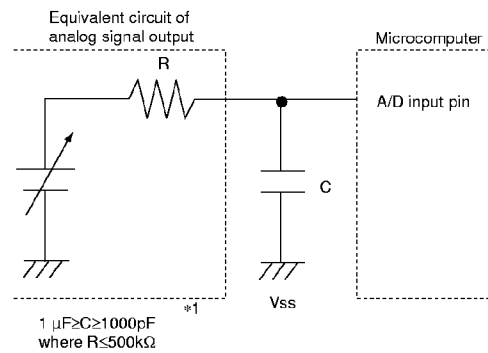

*1 These values are reference values.

Figure 6-3-5 Recommended Circuit When Using A/D Conversion

Chapter 7

AC Zero-Cross
Circuit/Noise Filter



7-1 Overview

The P21/SENS pin is the input pin for the AC zero-cross detection circuit. The AC zero-cross detection circuit outputs a high level when the input is at an intermediate level, and a low level at all other times.

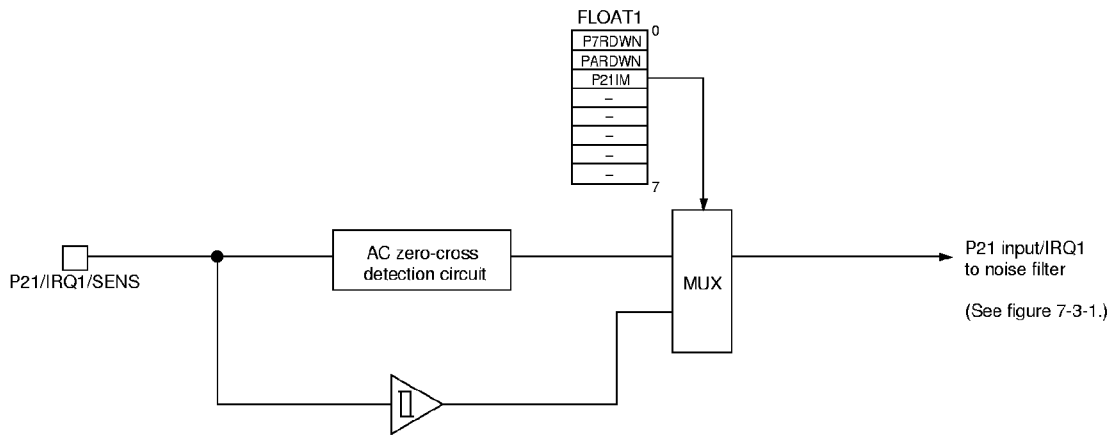

Figure 7-1-1 P21 Input Circuit Block Diagram

7-2 AC Zero-Cross Circuit Operation

7-2-1 Setup and Operation

Settings for zero-cross circuit operation are listed below.

- (1) Set the REDG1 flag of the IRQ1ICR register to select the valid edge for IRQ1.
- (2) Set the NF1EN and NF1CK2~1 flags of the NFCTR register to set the noise filter and its sampling clock.
- (3) With the P21IM flag of the FLOAT1 register, set the P21 pin to zero-cross detection.
- (4) An IRQ1 interrupt is generated when the waveform of the AC line voltage intersects $1/2V_{DD}$.

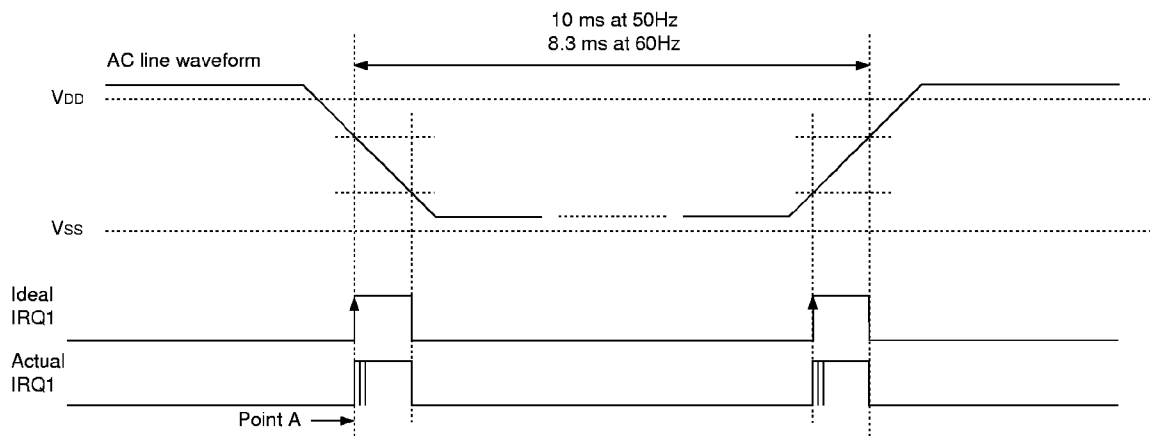
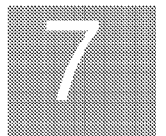

Figure 7-2-1 AC Line Waveform and IRQ Generation Timing

When the AC line waveform intersects $1/2V_{DD}$, actual IRQ interrupt requests will be generated multiple times. Therefore, the software must filter this signal before making any evaluations.

When noise filtering is selected for use, the amount of evaluation processing by the software will be reduced. However, if the OSC stops, a return from the backup mode will not be possible.



7-3 Noise Filter

7-3-1 Overview

External interrupt pins IRQ0 and IRQ1 contain noise filtering circuit. This circuitry can be used for remote control signal reception.

IRQ0: External interrupt 0

IRQ1: External interrupt 1

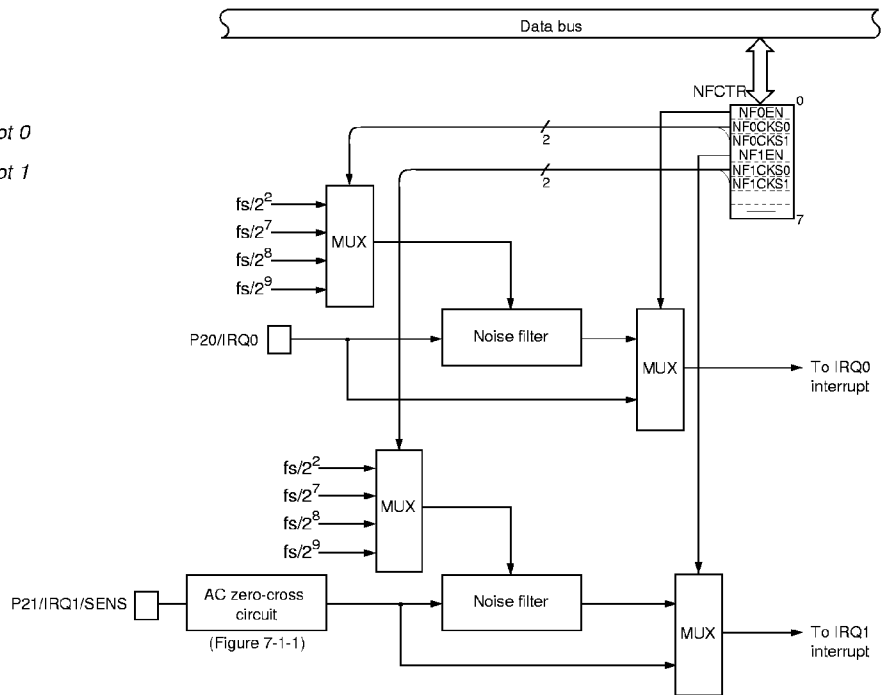

Figure 7-3-1 Noise Filtering Circuit Block Diagram

7-3-2 Example Input and Output Waveforms for Noise Filter

When the noise filter is used, the waveform input to the IRQ0 pin is sampled based on the clock specified by the NFOCKS0 and NFOCKS1 flags of the noise filter control register (NFCTR). The waveform input to the IRQ1 pin is also sampled based on the clock specified by the NFOCKS0 and NFOCKS1 flags. If the sampled level remains the same for 3 consecutive samples, it is sent the CPU; otherwise, the previous level is maintained.



Noise filtering cannot be used in the STOP or HALT modes.

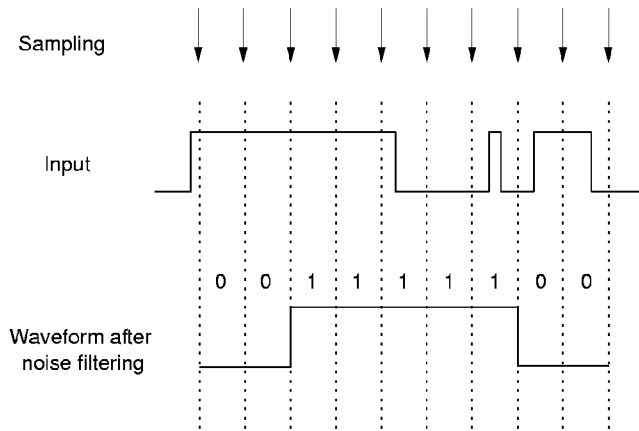

Figure 7-3-2 Noise Filter Input and Output Waveform Example

7-4 AC Zero-Cross Control Register

7-4-1 Overview

Three registers control the AC zero-cross circuit.

Table 7-4-1 AC Zero-Cross Control Register

Name	Address	R/W	Function
IRQ0ICR	X'03FE2'	R/W	External interrupt control register 0
IRQ1ICR	X'03FE3'	R/W	External interrupt control register 1
FLOAT1	X'03F4B'	R/W	Pin control register 1
NFCTR	X'03F8A'	R/W	Noise filter control register

[[REF 2-4-3](#) "Interrupt Control Registers ■ External Interrupt Control Registers"]

[[REF 3-2-2](#) "I/O Port Control Registers ■ Pin Control Registers"]

7-4-2 Noise Filter Control Register (NFCTR)

This 6-bit readable and writable register controls the noise filter.

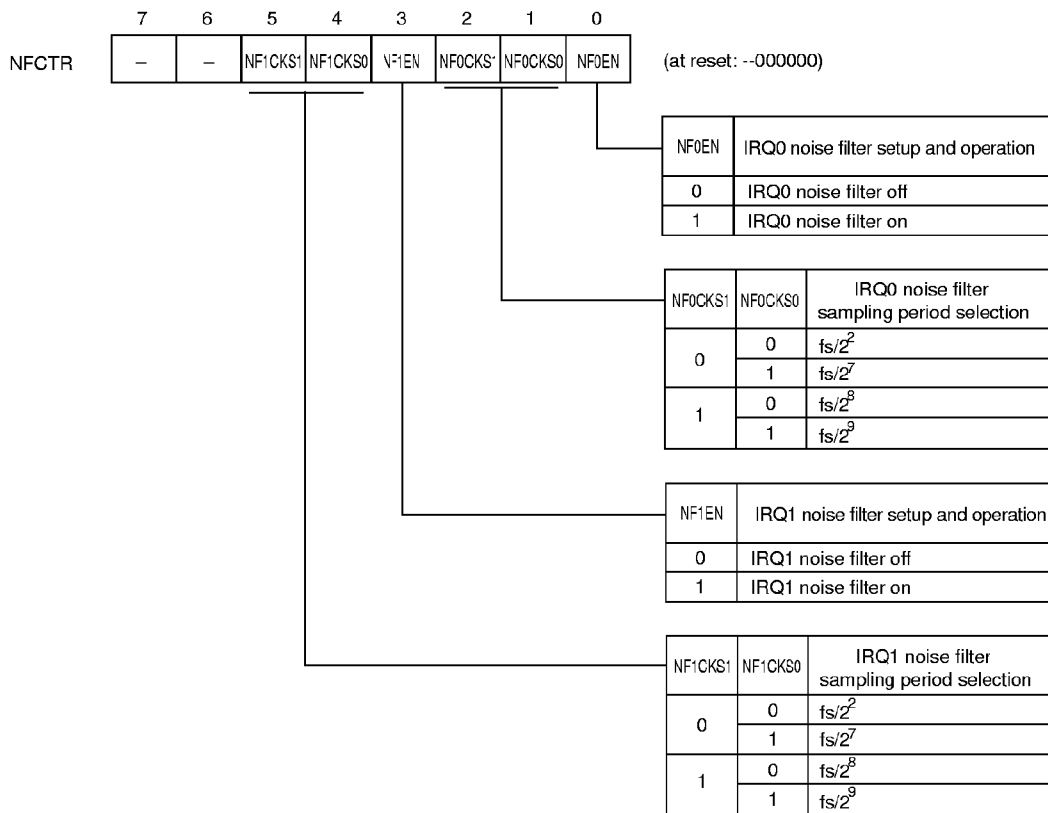

Figure 7-4-1 Noise Filter Control Register (NFCTR: X'03F8A', R/W)

Chapter 8

Automatic Data
Transfer Control
Function



8-1 Overview

The MN101C01D has the automatic data transfer control (ATC) function that can transfer data by hardware between the memory space and the internal special function register space.

Any of the interrupts listed in table 8-1-1 can be selected as the source to activate the ATC. Each time the interrupt once occurs, an 8-bit or 16-bit address is transferred. The number of transfers set in the transfer word count register has been reached, the automatic data transfer control interrupt is occurred.

For multiple (16-bit) transfers, disable interrupts from the interrupt control register of the selected ATC activation source (xxxIF=0).

The one-word transfer mode is used to transfer the 16-bit capture register, 10-bit A/D data, etc. The one-word transfer begins at an even address and consecutively transfers data from two consecutive addresses.

Table 8-1-1 Summary of the Automatic Data Transfer Control Function

Directions	Memory→Special Function Register Special Function Register→Memory (Memory→Memory transfers are not allowed)
Formats	1 byte (8 bits) or 1 word (16 bits)
Activation sources	A/D conversion complete interrupt Serial 0 transfer complete interrupt Serial 1 transfer complete interrupt Serial 2 transfer complete interrupt Timer 2 compare-match interrupt Timer 4 compare-match interrupt External interrupt IRQ0 External interrupt IRQ1

8-2 Automatic Data Transfer Control Operation

8-2-1 Overview

Automatic data transfer control (ATC) is specified by the automatic data control register (ATMD).

The ATC can transfer from 1 to 256 bytes, as specified in the ATCNT register. After the specified transfer is complete, the automatic data transfer interrupt (ATCIRQ) is generated.

The target address pointer (ATTAP) for the ATC can be specified to increment or hold constant.

8-2-2 Automatic Data Transfer

The transfer procedures are listed below.

(1) Disable the automatic data transfer

Set bit 6 (ATEN) of the ATMD register to "0" to disable the transfer function.

(At reset: 0)

(2) Select internal ATC

Set bit 7 (ATEXT) of the ATMD register to "0".

(At reset: 0)

(3) Select ATC activation source

Set bits 2~0 (ATBG2~0) of the ATMD register to select the interrupt that will activate the transfer.

000: A/D conversion complete interrupt

001: Serial 0 transfer complete interrupt

010: Serial 1 transfer complete interrupt

011: Serial 2 transfer complete interrupt

100: Timer 2 compare-match interrupt

101: Timer 4 compare-match interrupt

110: External interrupt IRQ0

111: External interrupt IRQ1

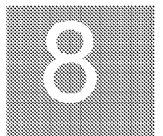

(4) Select transfer address mode

Select the transfer address mode with bit 3 (ATTINC) of the ATMD register.

- 0: Fixed ATTAP address
- 1: Incrementing ATTAP address

(5) Select transfer unit

Select the transfer unit with bit 5 (ATWID) of the ATMD register.

- 0: Byte (8-bit) transfer
- 1: Word (16-bit) transfer

(6) Select transfer direction

Select the transfer direction with bit 4 (ATDIR) of the ATMD register.

- 0: The transfer target address pointer (for memory) is specified as the source pointer.
- 1: The transfer target address pointer (for memory) is specified as the destination pointer.

(7) Set transfer word count

Set the transfer word count in the ATCNT register.

The order of settings in steps (2)~(7) can be changed.

(8) Enable data transfer

Set bit 6 (ATEN) of the ATMD register to "1" to enable the transfer function.

(9) Transfer complete

When all transfers are complete, ATEN will be cleared to "0" and an ATCIRQ interrupt generated.

8-2-3 Transfer Timing

The load cycle and store cycle execution times are determined by the memory space being accessed and the number of wait cycles set in the MEMCTR register.

The number of execution cycles for access of each type of memory are listed below.

- Special function register space: 3 cycles (when no wait cycles are set)
- Internal ROM/RAM: 2 cycles
- External ROM/RAM: 2 cycles (when no wait cycles are set)

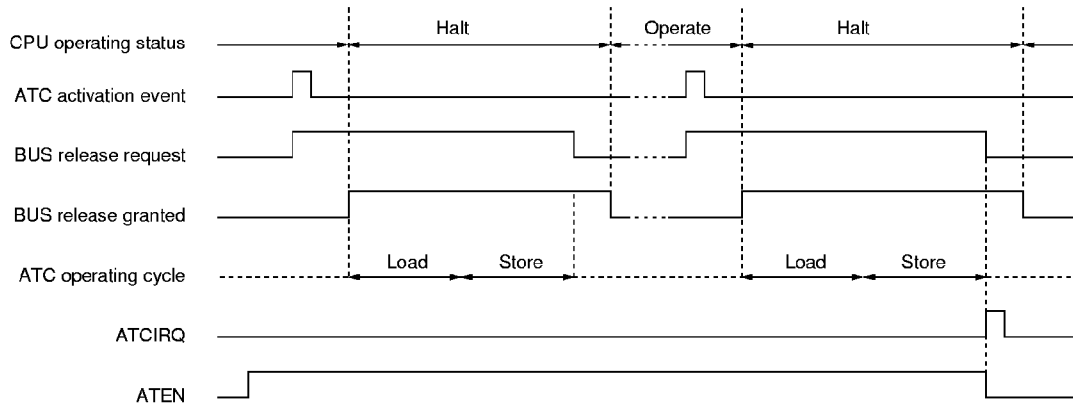

Figure 8-2-1 ATC Operation Timing Chart

8-3 Automatic Data Transfer Control Registers

8-3-1 Overview

Five registers to control the automatic data transfer control function (ATC). See table 8-3-1.

Table 8-3-1 Automatic Data Transfer Function Control Registers

Name	Address	R/W	Function
ATMD	X'03FA0'	R/W	Automatic data transfer control register
ATCNT	X'03FA1'	R/W	Transfer word counter
ATTAPL	X'03FA2'	R/W	Data transfer target address pointer (lower 8 bits)
ATTAPH	X'03FA3'	R/W	Data transfer target address pointer (upper 8 bits)
ATIAP	X'03FA4'	R/W	Data transfer internal address pointer

The automatic data transfer control register (ATMD) controls the operation of the ATC (activation source selection, transfer address mode selection, transfer direction/unit selection, and transfer enable status).

The data transfer target address pointer (ATTAPL, ATTAPH) points to a memory space.

The data transfer internal address pointer (ATIAP) points to an internal special function register space.

8-3-2 Automatic Data Transfer Control Register (ATMD)

This readable and writable 8-bit register controls the automatic data transfer control function.

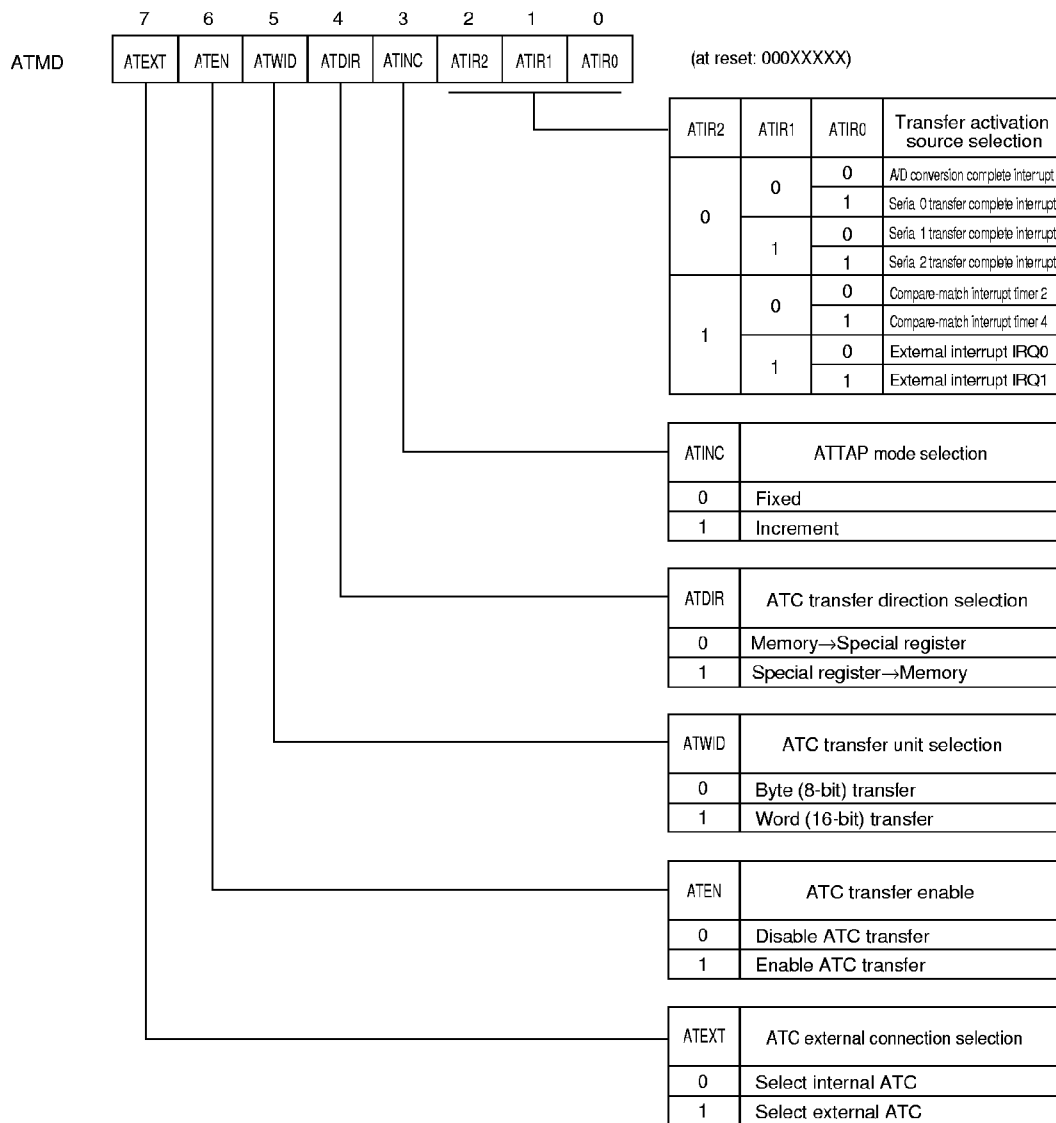

Figure 8-3-1 Automatic Data Transfer Control Register (ATMD: X'03FA0', R/W)

8-3-3 Transfer Word Counter (ATCNT)

This 8-bit readable and writable register sets the total number of bytes for the data transfer. The contents of ATCNT are decremented (-1) at each 1 byte transfer. When X'00' is reached, an automatic data transfer interrupt (ATCIRQ) is generated, the ATC transfer enabled flag (ATEN) is cleared to "0", and the transfer is complete.



Figure 8-3-2 Transfer Word Counter (ATCNT: X'03FA1', R/W)

8-3-4 Transfer Address Pointers

The transfer address pointers are a 16-bit and an 8-bit readable and writable register.

(1) Data transfer target address pointer (ATTAPH, ATTAPL)

This pointer specifies the RAM address of the transfer target.

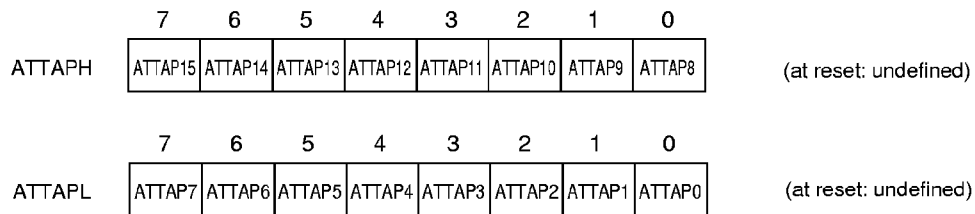

Figure 8-3-3 Data Transfer Target Address Pointer
(ATTAPH: X'03FA3', R/W; ATTAPL: X'03FA2', R/W)

(2) Data transfer internal address pointer (ATIAP)

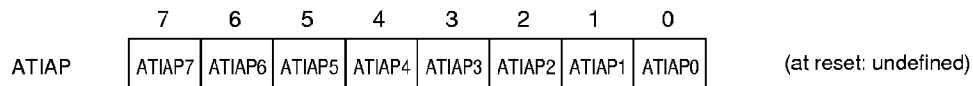

Figure 8-3-4 Data Transfer Internal Address Pointer (ATIAP: X'03FA4', R/W)

Appendices



Appendices

MN101C00 SERIES INSTRUCTION SET

Group	Mnemonic	Operation	Affected Flag				Code Size	Cycle	Repeat	Machine Code											Notes	Page		
			VF	NF	CF	ZF				Expand	1	2	3	4	5	6	7	8	9	10			11	
Data move instructions																								
MOV	MOV Dn,Dm	Dn→Dm	-	-	-	-	2	1		1010 DnDm												25		
	MOV imm8,Dm	imm8→Dm	-	-	-	-	4	2		1010DmDm <#8. ...>												25		
	MOV Dn,PSW	Dn→PSW	●	●	●	●	3	3	0010	1001	01Dn											26		
	MOV PSW,Dm	PSW→Dm	-	-	-	-	3	2	0010	0001	01Dm											26		
	MOV (An),Dm	mem8(An)→Dm	-	-	-	-	2	2		0100 1ADm												27		
	MOV (d8,An),Dm	mem8(d8+An)→Dm	-	-	-	-	4	2		0110 1ADm <d8. ...>											*1	27		
	MOV (d16,An),Dm	mem8(d16+An)→Dm	-	-	-	-	7	4	0010	0110	1ADm	<d16>						28			
	MOV (d4,SP),Dm	mem8(d4+SP)→Dm	-	-	-	-	3	2		0110 01Dm <d4>											*2	28		
	MOV (d8,SP),Dm	mem8(d8+SP)→Dm	-	-	-	-	5	3	0010	0110	01Dm	<d8	...>						*3	29				
	MOV (d16,SP),Dm	mem8(d16+SP)→Dm	-	-	-	-	7	4	0010	0110	00Dm	<d16>						29			
	MOV (io8),Dm	mem8(IOTOP+io8)→Dm	-	-	-	-	4	2		0110 00Dm <io8 ...>												30		
	MOV (abs8),Dm	mem8(abs8)→Dm	-	-	-	-	4	2		0100 01Dm <abs 8.>												30		
	MOV (abs12),Dm	mem8(abs12)→Dm	-	-	-	-	5	2		0100 00Dm <abs 12.. ...>												31		
	MOV (abs16),Dm	mem8(abs16)→Dm	-	-	-	-	7	4	0010	1100	00Dm	<abs 16..>						31				
	MOV Dn,(Am)	Dn→mem8(Am)	-	-	-	-	2	2		0101 1aDn												32		
	MOV Dn,(d8,Am)	Dn→mem8(d8+Am)	-	-	-	-	4	2		0111 1aDn <d8. ...>											*1	32		
	MOV Dn,(d16,Am)	Dn→mem8(d16+Am)	-	-	-	-	7	4	0010	0111	1aDn	<d16>						33			
	MOV Dn,(d4,SP)	Dn→mem8(d4+SP)	-	-	-	-	3	2		0111 01Dn <d4>											*2	33		
	MOV Dn,(d8,SP)	Dn→mem8(d8+SP)	-	-	-	-	5	3	0010	0111	01Dn	<d8	...>						*3	34				
	MOV Dn,(d16,SP)	Dn→mem8(d16+SP)	-	-	-	-	7	4	0010	0111	00Dn	<d16>						34			
	MOV Dn,(io8)	Dn→mem8(IOTOP+io8)	-	-	-	-	4	2		0111 00Dn <io8 ...>												35		
	MOV Dn,(abs8)	Dn→mem8(abs8)	-	-	-	-	4	2		0101 01Dn <abs 8.>												35		
	MOV Dn,(abs12)	Dn→mem8(abs12)	-	-	-	-	5	2		0101 00Dn <abs 12.. ...>												36		
	MOV Dn,(abs16)	Dn→mem8(abs16)	-	-	-	-	7	4	0010	1101	00Dn	<abs 16..>						36				
	MOV imm8,(io8)	imm8→mem8(IOTOP+io8)	-	-	-	-	6	3	0000	0010	<io8	...>	<#8.	...>						37				
	MOV imm8,(abs8)	imm8→mem8(abs8)	-	-	-	-	6	3	0001	0100	<abs 8.>	...>	<#8.	...>						37				
	MOV imm8,(abs12)	imm8→mem8(abs12)	-	-	-	-	7	3	0001	0101	<abs 12..	...>	<#8.	...>						38				
	MOV imm8,(abs16)	imm8→mem8(abs16)	-	-	-	-	9	5	0011	1101	1001	<abs 16..>	<#8.	...>						38		
	MOV Dn,(HA)	Dn→mem8(HA)	-	-	-	-	2	2		1101 00Dn												39		
	MOVW	MOVW (An),DWm	mem16(An)→DWm	-	-	-	-	2	3		1110 00Ad												40	
		MOVW (An),Am	mem16(An)→Am	-	-	-	-	3	4	0010	1110	10Aa										*4	40	
		MOVW (d4,SP),DWm	mem16(d4+SP)→DWm	-	-	-	-	3	3		1110 011d <d4>											*2	41	
		MOVW (d4,SP),Am	mem16(d4+SP)→Am	-	-	-	-	3	3		1110 010a <d4>											*2	41	
MOVW (d8,SP),DWm		mem16(d8+SP)→DWm	-	-	-	-	5	4	0010	1110	011d	<d8	...>						*3	42				
MOVW (d8,SP),Am		mem16(d8+SP)→Am	-	-	-	-	5	4	0010	1110	010a	<d8	...>						*3	42				
MOVW (d16,SP),DWm		mem16(d16+SP)→DWm	-	-	-	-	7	5	0010	1110	001d	<d16>						43			
MOVW (d16,SP),Am		mem16(d16+SP)→Am	-	-	-	-	7	5	0010	1110	000a	<d16>						43			
MOVW (abs8),DWm		mem16(abs8)→DWm	-	-	-	-	4	3		1100 011d <abs 8.>												44		
MOVW (abs8),Am		mem16(abs8)→Am	-	-	-	-	4	3		1100 010a <abs 8.>												44		
MOVW (abs16),DWm		mem16(abs16)→DWm	-	-	-	-	7	5	0010	1100	011d	<abs 16..>						45				
MOVW (abs16),Am		mem16(abs16)→Am	-	-	-	-	7	5	0010	1100	010a	<abs 16..>						45				
MOVW DWn,(Am)		DWn→mem16(Am)	-	-	-	-	2	3		1111 00aD												46		
MOVW An,(Am)		An→mem16(Am)	-	-	-	-	3	4	0010	1111	10aA										*4	46		
MOVW DWn,(d4,SP)		DWn→mem16(d4+SP)	-	-	-	-	3	3		1111 011D <d4>											*2	47		
MOVW An,(d4,SP)		An→mem16(d4+SP)	-	-	-	-	3	3		1111 010A <d4>											*2	47		
MOVW DWn,(d8,SP)		DWn→mem16(d8+SP)	-	-	-	-	5	4	0010	1111	011D	<d8	...>						*3	48				
MOVW An,(d8,SP)		An→mem16(d8+SP)	-	-	-	-	5	4	0010	1111	010A	<d8	...>						*3	48				
MOVW DWn,(d16,SP)		DWn→mem16(d16+SP)	-	-	-	-	7	5	0010	1111	001D	<d16>						49			
MOVW An,(d16,SP)		An→mem16(d16+SP)	-	-	-	-	7	5	0010	1111	000A	<d16>						49			
MOVW DWn,(abs8)		DWn→mem16(abs8)	-	-	-	-	4	3		1101 011D <abs 8.>												50		
MOVW An,(abs8)		An→mem16(abs8)	-	-	-	-	4	3		1101 010A <abs 8.>												50		
MOVW DWn,(abs16)		DWn→mem16(abs16)	-	-	-	-	7	5	0010	1101	011D	<abs 16..>						51				
MOVW An,(abs16)		An→mem16(abs16)	-	-	-	-	7	5	0010	1101	010A	<abs 16..>						51				
MOVW DWn,(HA)		DWn→mem16(HA)	-	-	-	-	2	3		1001 010D												52		
MOVW An,(HA)		An→mem16(HA)	-	-	-	-	2	3		1001 011A												52		
MCVW imm8,DWm		sign(imm8)→DWm	-	-	-	-	4	2	0000	110d	<#8.	...>						*5	53					
MCVW imm8,Am		zero(imm8)→Am	-	-	-	-	4	2	0000	111a	<#8.	...>						*6	53					
MCVW imm16,DWm		imm16→DWm	-	-	-	-	6	3		1100 111d <#16										>		54

Note: "Page" refers to the corresponding page in the Instruction Manual.

- *1 d8 sign extended
- *2 d4 zero extended
- *3 d8 zero extended
- *4 A=An, a=Am
- *5 #8 sign extended
- *6 #8 zero extended

Appendices

MN101C00 SERIES INSTRUCTION SET

Group	Mnemonic	Operation	Affected Flag			Code Size	Cycle	Repeat	Machine Code											Notes	Page
			VF	NF	CF				ZF	1	2	3	4	5	6	7	8	9	10		
TBZ	TBZ (io8)bp,label	if(mem8(OTOP+io8)bp=0),PC+7-d7(label)+H→PC if(mem8(OTOP+io8)bp=1),PC+7→PC	0	●	0	●	7	6/7		0011	0100	0bp.	<io8	...	<d7.	...H		*1	123		
	TBZ (io8)bp,label	if(mem8(OTOP+io8)bp=0),PC+8-d11(label)+H→PC if(mem8(OTOP+io8)bp=1),PC+8→PC	0	●	0	●	8	6/7		0011	0100	1bp.	<io8	...	<d11	...H		*2	123		
	TBZ (abs16)bp,label	if(mem8(abs16)bp=0),PC+5+c7(label)+H→PC if(mem8(abs16)bp=1),PC+9→PC	0	●	0	●	9	7/8		0011	1110	0bp.	<abs	16..	...	<d7.	...H		*1	124	
	TBZ (abs16)bp,label	if(mem8(abs16)bp=0),PC+10+d11(label)+H→PC if(mem8(abs16)bp=1),PC+10→PC	0	●	0	●	10	7/8		0011	1110	1bp.	<abs	16..	...	<d11	...H		*2	124	
TBNZ	TBNZ (abs8)bp,label	if(mem8(abs8)bp=1),PC+7-d7(label)+H→PC if(mem8(abs8)bp=0),PC+7→PC	0	●	0	●	7	6/7		0011	0001	0bp.	<abs	8.>	<d7.	...H		*1	125		
	TBNZ (abs8)bp,label	if(mem8(abs8)bp=1),PC+8-d11(label)+H→PC if(mem8(abs8)bp=0),PC+8→PC	0	●	0	●	8	6/7		0011	0001	1bp.	<abs	8.>	<d11	...H		*2	125		
	TBNZ (io8)bp,label	if(mem8(io)bp=1),PC+7+d7(label)+H→PC if(mem8(io)bp=0),PC+7→PC	0	●	0	●	7	6/7		0011	0101	0bp.	<io8	...	<d7.	...H		*1	126		
	TBNZ (io8)bp,label	if(mem8(io)bp=1),PC+8+d11(label)+H→PC if(mem8(io)bp=0),PC+8→PC	0	●	0	●	8	6/7		0011	0101	1bp.	<io8	...	<d11	...H		*2	126		
	TBNZ (abs16)bp,label	if(mem8(abs16)bp=1),PC+5+c7(label)+H→PC if(mem8(abs16)bp=0),PC+9→PC	0	●	0	●	9	7/8		0011	1111	0bp.	<abs	16..	...	<d7.	...H		*1	127	
	TBNZ (abs16)bp,label	if(mem8(abs16)bp=1),PC+10+d11(label)+H→PC if(mem8(abs16)bp=0),PC+10→PC	0	●	0	●	10	7/8		0011	1111	1bp.	<abs	16..	...	<d11	...H		*2	127	
JMP	JMP (An)	0→PC.17-16,An→PC.15-0,0→PC.H	-	-	-	-	3	4		0010	0001	00A0							128		
	JMP label	abs18(label)+H→PC	-	-	-	-	7	5		0011	1001	0aaH	<abs	18.b	p15~	0..>		*5	128		
JSR	JSR (An)	SP-3→SP,(PC+3).bp7-0→mem8(SP) (PC+3).bp15-8→mem8(SP+1) (PC+3).H→mem8(SP+2).bp7, 0→mem8(SP+2).bp6~2, (PC+3).bp17-16→mem8(SP+2).bp1-0 0→PC.bp17-16 An→PC.bp15-0,0→PC.H	-	-	-	-	3	7		0010	0001	00A1							129		
	JSR label	SP-3→SP,(PC+5).bp7-0→mem8(SP) (PC+5).bp15-8→mem8(SP+1) (PC+5).H→mem8(SP+2).bp7, 0→mem8(SP+2).bp6~2, (PC+5).bp17-16→mem8(SP+2).bp1-0 PC+5+d12(label)+H→PC	-	-	-	-	5	6			0001	000H	<d12			*3	129		
	JSR label	SP-3→SP,(PC+6).bp7-0→mem8(SP) (PC+6).bp15-8→mem8(SP+1) (PC+6).H→mem8(SP+2).bp7, 0→mem8(SP+2).bp6~2, (PC+6).bp17-16→mem8(SP+2).bp1-0 PC+6+d16(label)+H→PC	-	-	-	-	6	7			0001	001H	<d16			*4	130		
	JSR label	SP-3→SP,(PC+7).bp7-0→mem8(SP) (PC+7).bp15-8→mem8(SP+1) (PC+7).H→mem8(SP+2).bp7, 0→mem8(SP+2).bp6~2, (PC+7).bp17-16→mem8(SP+2).bp1-0 abs18(label)+H→PC	-	-	-	-	7	8		0011	1001	1aaH	<abs	18.b	p15~	0..>		*5	130		
	JSRV (tb4)	SP-3→SP,(PC+3).bp7-0→mem8(SP) (PC+3).bp15-8→mem8(SP+1) (PC+3).H→mem8(SP+2).bp7 0→mem8(SP+2).bp6~2, (PC+3).bp17-16→mem8(SP+2).bp1-0 mem8(x'004080+tb4<<2)→PC.bp7-0 mem8(x'004080+tb4<<2+1)→PC.bp15-8 mem8(x'004080+tb4<<2+2)bp7→PC.H mem8(x'004080+tb4<<2+2).bp1-0 PC.bp17-16 PC+2→PC	-	-	-	-	3	9			1111	1110	<t4>							131	
	NOP	NOP		-	-	-	-	2	1		0000	0000								132	

Note: "Page" refers to the corresponding page in the Instruction Manual.

- *1 d7 sign extended
- *2 c11 sign extended
- *3 c12 sign extended
- *4 c16 sign extended
- *5 aa=abs18.17-16

MN101C00 SERIES INSTRUCTION SET

Group	Mnemonic	Operation	Affected Flag			Code Size	Cycle	Repeat	Machine Code											Notes	Page				
			VF	NF	CF				ZF	Expand	1	2	3	4	5	6	7	8	9			10	11		
RTS	RTS	mem8(SP)→(PC).bp7~0 mem8(SP+1)→(PC+3).bp15~8 mem8(SP+2).bp7→(PC+3).H mem8(SP+2).bp1~0→(PC+3).tp17~16 SP+3→SP	-	-	-	2	7		0000	0001														133	
RTI	RTI	mem8(SP)→PSW mem8(SP+1)→(PC).bp7~0 mem8(SP+2)→(PC+3).bp15~8 mem8(SP+3).bp7→(PC+3).H mem8(SP+3).bp1~0→(PC+3).bp17~16 mem8(SP+4)→HA-l mem8(SP+5)→HA-h SP+6→SP	●	●	●	2	11		0000	0011														134	
Control instruction																									
REP	REP imm3	imm3→RPC	--	--	--	3	2		0010	0001	1rep													*1	135

Note: "Page" refers to the corresponding page in the Instruction Manual.

*1 Number of repeats is 0 when imm3=0.

MN101C00 SERIES INSTRUCTION MAP

1st nibble		2nd nibble															
0	1	2	3	4	5	6	7	8	9	A	B	C	D	E	F		
0	NOP	RTS	MOV #8,(io8)	RTI	CMP #8,(abs8)/(abs12)	POP An		ADD #8,Dm				MOVW #8,DWm	MOVW #8,Am				
1	JSR d12(label)	JSR d16(label)		MOV #8,(abs8)/(abs12)		PUSH An		OR #8,Dm				AND #8,Dm					
2	When the extension code is b'0010'																
3	When the extension code is b'0011'																
4	MOV (abs12),Dm			MOV (abs8),Dm			MOV (An),Dm										
5	MOV Dn,(abs12)			MOV Dn,(abs8)			MOV Dn,(Am)										
6	MOV (io8),Dm			MOV (d4,SP),Dm			MOV (d8,An),Dm										
7	MOV Dn,(io8)			MOV Dn,(d4,SP)			MOV Dn,(d8,Am)										
8	ADD #4,Dm			SUB Dn,Dn			BGE d7		BRA d7	BEQ d7	BNE d7	BCC d7	BCS d7	BLT d7	BLE d7		
9	BEQ d4		BNE d4	MOVW DWn,(HA)		MOVW An,(HA)		BGE d11	BRA d11	BEQ d11	BNE d11	BCC d11	BCS d11	BLT d11	BLE d11		
A	MOV Dn,Dm / MOV #8,Dm																
B	BSET (abs8)bp							BCLR (abs8)bp									
C	CMP #8,Dm			MOVW (abs8),Am		MOVW (abs8),DWn		CBEQ #8,Dm,d7			CMPW #16,DWm		MOVW #16,DWm				
D	MOV Dn,(HA)			MOVW An,(abs8)		MOVW DWn,(abs8)		CBNE #8,Dm,d7			CMPW #16,Am		MOVW #16,Am				
E	MOVW (An),DWm			MOVW (d4,SP),Am		MOVW (d4,SP),DWm		POP Dn			ADDW #4,Am		BRA d4				
F	MOVW DWn,(Am)			MOVW An,(d4,SP)		MOVW DWn,(d4,SP)		PUSH Dn			ADDW #8,SP	ADDW #4,SP	JSRV (tbl4)				

Extension code: b'0010'

1st nibble		2nd nibble															
0	1	2	3	4	5	6	7	8	9	A	B	C	D	E	F		
0	MOVW An,Am			CMPW An,Am			MOVW SP,Am		MOVW An,SP		BTST #8,Dm						
1	JMP (A0)	JSR (A0)	JMP (A1)	JSR (A1)	MOV PSW,Dm			REP #3									
2		BGT d7	BHI d7	BLS d7	BNC d7	BNS d7	BVC d7	BVS d7	NOT Dn			ROR Dn					
3		BGT d11	BHI d11	BLS d11	BNC d11	BNS d11	BVC d11	BVS d11	ASR Dn			LSR Dn					
4	SUBW DWn,DWm			SUBW #16,DWm		SUBW #16,Am		SUBW DWn,Am			MOVW DWn,Am						
5	ADDW DWn,DWm			ADDW #16,DWm		ADDW #16,Am		ADDW DWn,Am			CMPW DWn,Am						
6	MOV (d16,SP),Dm			MOV (d8,SP),Dm			MOV (d16,An),Dm										
7	MOV Dn,(d16,SP)			MOV Dn,(d8,SP)			MOV Dn,(d16,Am)										
8	MOVW DWn,DWm (NOPL @n=m)			CMPW DWn,DWm			ADDUW Dn,Am										
9	EXT Dn,DWm		AND #8,PSW	OR #8,PSW	MOV Dn,PSW			ADDSW Dn,Am									
A	SUB Dn,Dm / SUB #8,Dm																
B	SUBC Dn,Dm																
C	MOV (abs16),Dm			MOVW (abs16),Am		MOVW (abs16),DWm		CBEQ #8,Dm,d12			MOVW An,DWm						
D	MOV Dn,(abs16)			MOVW An,(abs16)		MOVW DWn,(abs16)		CBNE #8,Dm,d12			CBEQ #8,(abs8),d7/d11		CBNE #8,(abs8),d7/d11				
E	MOVW (d16,SP),Am		MOVW (d16,SP),DWm	MOVW (d8,SP),Am		MOVW (d8,SP),DWm		MOVW (An),Am			ADDW #8,Am		DIVU				
F	MOVW An,(d16,SP)		MOVW DWn,(d16,SP)	MOVW An,(d8,SP)		MOVW DWn,(d8,SP)		MOVW An,(Am)			ADDW #16,SP		MULU				

Extension code: b'0011'
 2nd nibble\3rd nibble

	0	1	2	3	4	5	6	7	8	9	A	B	C	D	E	F
0	TBZ (abs8)bp,d7								TBZ (abs8)bp,d11							
1	TBNZ (abs8)bp,d7								TBNZ (abs8)bp,d11							
2	CMP Dn,Dm															
3	ADD Dn,Dm															
4	TBZ (io8)bp,c7								TBZ (io8)bp,d11							
5	TBNZ (io8)bp,d7								TBNZ (io8)bp,d11							
6	OR Dn,Dm															
7	AND Dn,Dm															
8	BSET (io8)bp								BCLR (io8)bp							
9	JMP abs18(label)								JSR abs18(label)							
A	XOR Dn,Dm / XOR #8,Dm															
B	ADDC Dn,Dm															
C	BSET (abs16)bp								BCLR (abs16)bp							
D	BTST (abs16)bp								cmp #8,(abs16)	mov #8,(abs16)					CBEQ #8,(abs16),d7/1	CBNE #8,(abs16),d7/1
E	TBZ (abs16)bp,d7								TBZ (abs16)bp,d11							
F	TBNZ (abs16)bp,d7								TBNZ (abs16)bp,d11							

Summary of Special Function Registers (1/6)

Address	Register	Bit Symbol								Reference Page
		Bit 7	Bit 6	Bit 5	Bit 4	Bit 3	Bit 2	Bit 1	Bit 0	
X'3F00'	CPUM				Must be set to "0"	STOP transfer request	HALT transfer request	Oscillation control		MN101C00 Series LSI Manual
X'3F01'	MEMCTR	IOW1	IOW0	IVBA	EXMEM	EXWH	IRWE	EXW1	EXW0	34
		Specifies number of I/O bus wait cycles		Specifies base address of interrupt vector table	Specifies external memory expansion mode	Switches fixed wait mode/handshake mode	Software write setting for interrupt request flag	Specifies number of wait cycles for external memory		
X'3F02'	WDCTR								WDEN	117
									Enables watchdog timer	
X'3F03'	DLYCTR	BUZOE	BUZCK1	BUZCK0				DLYS1	DLYS0	118
		Selects P06 output	Selects buzzer output frequency					Sets oscillation stabilization wait period		
X'3F0E'	EXADV	EXADV3	EXADV2	EXADV1						35
		Enables A17-A16 address output during memory expansion mode	Enables A15-A12 address output during memory expansion mode	Enables A11-A8 address output during memory expansion mode						
X'3F10'	P0OUT		P0OUT6	P0OUT5	P0OUT4	P0OUT3	P0OUT2	P0OUT1	P0OUT0	49,54
			Port 0 output							
X'3F11'	P1OUT				P1OUT4	P1OUT3	P1OUT2	P1OUT1	P1OUT0	49,54
			Port 1 output							
X'3F12'	P2OUT	P2OUT7								49,54
		Port 2 output								
X'3F13'	P3OUT	P3OUT7	P3OUT6	P3OUT5	P3OUT4	P3OUT3	P3OUT2	P3OUT1	P3OUT0	49,54
		Port 3 output								
X'3F14'	P4OUT	P4OUT7	P4OUT6	P4OUT5	P4OUT4	P4OUT3	P4OUT2	P4OUT1	P4OUT0	49,54
		Port 4 output								
X'3F15'	P5OUT				P5OUT4	P5OUT3	P5OUT2	P5OUT1	P5OUT0	49,54
					Port 5 output					
X'3F16'	P6OUT	P6OUT7	P6OUT6	P6OUT5	P6OUT4	P6OUT3	P6OUT2	P6OUT1	P6OUT0	49,54
		Port 6 output								
X'3F17'	P7OUT	P7OUT7	P7OUT6	P7OUT5	P7OUT4	P7OUT3	P7OUT2	P7OUT1	P7OUT0	49,54
		Port 7 output								
X'3F18'	P8OUT	P8OUT7	P8OUT6	P8OUT5	P8OUT4	P8OUT3	P8OUT2	P8OUT1	P8OUT0	49,54
		Port 8 output								
X'3F1F'	SYSDM	SYSDM7	SYSDM6	SYSDM5	SYSDM4	SYSDM3	SYSDM2	SYSDM1	SYSDM0	49,55
		I/O port/Synchronous output control								
X'3F20'	P0IN		P0IN6	P0IN5	P0IN4	P0IN3	P0IN2	P0IN1	P0IN0	49,54
			Port 0 input							
X'3F21'	P1IN				P1IN4	P1IN3	P1IN2	P1IN1	P1IN0	49,54
			Port 1 input							
X'3F22'	P2IN				P2IN4	P2IN3	P2IN2	P2IN1	P2IN0	49,54
			Port 2 input							
X'3F23'	P3IN	P3IN7	P3IN6	P3IN5	P3IN4	P3IN3	P3IN2	P3IN1	P3IN0	49,54
		Port 3 input								
X'3F24'	P4IN	P4IN7	P4IN6	P4IN5	P4IN4	P4IN3	P4IN2	P4IN1	P4IN0	49,54
		Port 4 input								
X'3F25'	P5IN				P5IN4	P5IN3	P5IN2	P5IN1	P5IN0	49,54
			Port 5 input							

Summary of Special Function Registers (2/6)

Address	Register	Bit Symbol								Reference Page
		Bit 7	Bit 6	Bit 5	Bit 4	Bit 3	Bit 2	Bit 1	Bit 0	
X'3F26'	P6IN	P6IN7	P6IN6	P6IN5	P6IN4	P6IN3	P6IN2	P6IN1	P6IN0	49,54
Port 6 input										
X'3F27'	P7IN	P7IN7	P7IN6	P7IN5	P7IN4	P7IN3	P7IN2	P7IN1	P7IN0	49,54
Port 7 input										
X'3F28'	P8IN	P8IN7	P8IN6	P8IN5	P8IN4	P8IN3	P8IN2	P8IN1	P8IN0	49,54
Port 8 input										
X'3F2A'	PAIN	PAIN7	PAIN6	PAIN5	PAIN4	PAIN3	PAIN2	PAIN1	PAIN0	49,54
Port A input										
X'3F30'	P0DIR		P0DIR6	P0DIR5	P0DIR4	P0DIR3	P0DIR2	P0DIR1	P0DIR0	49,54
Port 0 I/O direction control										
X'3F31'	P1DIR				P1DIR4	P1DIR3	P1DIR2	P1DIR1	P1DIR0	49,54
Port 1 I/O direction control										
X'3F33'	P3DIR	P3DIR7	P3DIR6	P3DIR5	P3DIR4	P3DIR3	P3DIR2	P3DIR1	P3DIR0	49,54
Port 3 I/O direction control										
X'3F34'	P4DIR	P4DIR7	P4DIR6	P4DIR5	P4DIR4	P4DIR3	P4DIR2	P4DIR1	P4DIR0	50,54
Port 4 I/O direction control										
X'3F35'	P5DIR				P5DIR4	P5DIR3	P5DIR2	P5DIR1	P5DIR0	50,54
Port 5 I/O direction control										
X'3F36'	P6DIR	P6DIR7	P6DIR6	P6DIR5	P6DIR4	P6DIR3	P6DIR2	P6DIR1	P6DIR0	50,54
Port 6 I/O direction control										
X'3F37'	P7DIR	P7DIR7	P7DIR6	P7DIR5	P7DIR4	P7DIR3	P7DIR2	P7DIR1	P7DIR0	50,54
Port 7 I/O direction control										
X'3F38'	P8DIR	P8DIR7	P8DIR6	P8DIR5	P8DIR4	P8DIR3	P8DIR2	P8DIR1	P8DIR0	50,54
Port 8 I/O direction control										
X'3F39'	P1OMD				P14TCO	P13TCO	P12TCO	P11TCO	P10TCO	50,55
I/O port/Special function pin control										
X'3F3A'	PAIMD	PAAIN7	PAAIN6	PAAIN5	PAAIN4	PAAIN3	PAAIN2	PAAIN1	PAAIN0	50,55
I/O port/Special function pin control										
X'3F3C'	P4IMD	IRQ4SEL Select IRQ interrupt source				P4KYEN4 Select PA6, PA7 key interrupt	P4KYEN3 Select PA4, PA5 key interrupt	P4KYEN2 Select PA2, PA3 key interrupt	P4KYEN1 Select PA0, PA1 key interrupt	50,55
X'3F40'	P0PLU		P0PLU6	P0PLU5	P0PLU4	P0PLU3	P0PLU2	P0PLU1	P0PLU0	
Port 0 pull-up resistor ON/OFF control										
X'3F41'	P1PLU				P1PLU4	P1PLU3	P1PLU2	P1PLU1	P1PLU0	50,54
Port 1 pull-up resistor ON/OFF control										
X'3F42'	P2PLU				P2PLU4	P2PLU3	P2PLU2	P2PLU1	P2PLU0	50,54
Port 2 pull-up resistor ON/OFF control										
X'3F43'	P3PLU	P3PLU7	P3PLU6	P3PLU5	P3PLU4	P3PLU3	P3PLU2	P3PLU1	P3PLU0	50,54
Port 3 pull-up/pull-down resistor ON/OFF control										
X'3F44'	P4PLU	P4PLU7	P4PLU6	P4PLU5	P4PLU4	P4PLU3	P4PLU2	P4PLU1	P4PLU0	50,54
Port 4 pull-up resistor ON/OFF control										
X'3F45'	P5PLU				P5PLU4	P5PLU3	P5PLU2	P5PLU1	P5PLU0	50,54
Port 5 pull-up resistor ON/OFF control										

Summary of Special Function Registers (3/6)

Address	Register	Bit Symbol								Reference Page	
		Bit 7	Bit 6	Bit 5	Bit 4	Bit 3	Bit 2	Bit 1	Bit 0		
X'3F46'	P6PLU	P6PLU7	P6PLU6	P6PLU5	P6PLU4	P6PLU3	P6PLU2	P6PLU1	P6PLU0	50,54	
		Port 6 pull-up resistor ON/OFF control									
X'3F47'	P7PLUD	P7PLUD7	P7PLUD6	P7PLUD5	P7PLUD4	P7PLUD3	P7PLUD2	P7PLUD1	P7PLUD0	50,54	
		Port 7 pull-up/pull-down resistor ON/OFF control									
X'3F48'	P8PLU	P8PLU7	P8PLU6	P8PLU5	P8PLU4	P8PLU3	P8PLU2	P8PLU1	P8PLU0	50,54	
		Port 8 pull-up resistor ON/OFF control									
X'3F4A'	PAPLUD	PAPLUD7	PAPLUD6	PAPLUD5	PAPLUD4	PAPLUD3	PAPLUD2	PAPLUD1	PAPLUD0	50,54	
		Port A pull-up/pull-down resistor ON/OFF control									
X'3F4B'	FLOAT1						P21M	PARDWN	P7RDWN	50,57	
						Select P21 input mode	Selects port A pull-up/pull-down	Selects port 7 pull-up/pull-down			
X'3F4C'	FLOAT2								P7SYEVS2	P7SYEVS1	50,57
								Selects P7 synchronous output event			
X'3F50'	SC0MD0	SC0CE0		SC0CE1	SC0DIR	SC0STE	SC0LNG2	SC0LNG1	SC0LNG0	146	
		Set edges for input of received data and output of transmission data		Specifies first bit of transfer	Selects synchronous serial start condition	Number of transfer bits					
X'3F51'	SC0MD1			SC0CKM	SC0CK1	SC0CK0	SC0BRKF	SC0ERE	SC0TRI	147	
				Selects 1/8th of frequency	Selects clock source		Break status reception monitor	Error monitor	Transmit/receive interrupt request flag		
X'3F52'	SC0MD2			SC0BRKE	SC0FM1	SC0FM0	SC0PM1	SC0PM0	SC0NPE	148	
				Controls break status transmission	Specifies frame mode		Specifies added bit		Enables parity		
X'3F53'	SC0MD3			SC0IOM	SC0SBOM	SC0SBTM	SC0SBOS	SC0SBIS	SC0SBTS	149	
				SB0/SBC0 pin connection	Selects SBO0 pin format	Selects SBT0 pin format	Selects SBO0 pin function	Controls SB0 input	Selects SBT0 pin function		
X'3F54'	SC0CTR	SC0BSY	SC0CMD			SC0FEF	SC0PEK	SC0ORE		154	
		Status of serial bus	Selects synchronous serial UART			Detect framing errors	Detect parity errors	Detect overrun errors			
X'3F55'	SC0TRB	SC0TRB7	SC0TRB6	SC0TRB5	SC0TRB4	SC0TRB3	SC0TRB2	SC0TRB1	SC0TRB0	145	
		Serial interface 0 transmit/receive shift register									
X'3F56'	SC0RXB	SC0RXB7	SC0RXB6	SC0RXB5	SC0RXB4	SC0RXB3	SC0RXB2	SC0RXB1	SC0RXB0	145	
		Serial interface 0 receive data buffer									
X'3F57'	SC1MD0	SC1BSY	SC1CE0	SC1CE1	SC1DIR	SC1STE	SC1LNG2	SC1LNG1	SC1LNG0	150	
		Status of serial bus	Set edges for input of received data and output of transmission data	Specifies first bit of transfer	Selects synchronous serial start condition	Number of transfer bits					
X'3F58'	SC1MD1			SC1SBOM	SC1SBTM	SC1SBOS	SC1SBIS	SC1SBTS	SC1CK1	SC1CK0	151
				Selects SBO1 pin format	Selects SBT1 pin format	Selects SBO1 pin function	Selects SB1 pin function	Selects SBT1 pin function	Selects clock source		
X'3F59'	SC1TRB	SC1TRB7	SC1TRB6	SC1TRB5	SC1TRB4	SC1TRB3	SC1TRB2	SC1TRB1	SC1TRB0	145	
		Serial interface 1 transmit/receive shift register									
X'3F5A'	SC2MD0	SC2CE0	SC2CMD	SC2DIR	SC2STE	SC2LNG3	SC2LNG2	SC2LNG1	SC2LNG0	152	
		Set edges for input of received data	Selects synchronous serial IIC	Specifies first bit of transfer	Selects synchronous serial start condition	Number of transfer bits					
X'3F5B'	SC2MD1	SC2SBOM	SC2SBTM	SC2SBOS	SC2SBIS	SC2SBTS	SC2CK2	SC2CK1	SC2CK0	153	
		Selects SBO2 pin format	Selects SBT2 pin format	Selects SBO2 pin function	Controls SB2 input	Selects SBT2 pin function	Selects clock source				
X'3F5C'	SC2CTR	SC2BSY	SC2SBOM	SC2SPKF	SC2STKF	SC2SPEN	SC2STEN	SC2ACKS	SC2ACKO	155	
		Status of serial bus	Connects SB2/SC2 pin	Detects stop condition flag	Detects start condition flag	enables stop condition flag	enables start condition flag	ACK bit enable	ACK bit level		
X'3F5D'	SC2TRB	SC2TRB7	SC2TRB6	SC2TRB5	SC2TRB4	SC2TRB3	SC2TRB2	SC2TRB1	SC2TRB0	145	
		Serial interface 2 transmit/receive shift register									
X'3F60'	TM0BC	TM0BC7	TM0BC6	TM0BC5	TM0BC4	TM0BC3	TM0BC2	TM0BC1	TM0BC0	107	
		Binary counter 0									

Summary of Special Function Registers (4/6)

Address	Register	Bit Symbol								Reference Page	
		Bit 7	Bit 6	Bit 5	Bit 4	Bit 3	Bit 2	Bit 1	Bit 0		
X'3F61'	TM1BC	TM1BC7	TM1BC6	TM1BC5	TM1BC4	TM1BC3	TM1BC2	TM1BC1	TM1BC0	107	
		Binary counter 1									
X'3F62'	TM2BC	TM2BC7	TM2BC6	TM2BC5	TM2BC4	TM2BC3	TM2BC2	TM2BC1	TM2BC0	108	
		Binary counter 2									
X'3F63'	TM3BC	TM3BC7	TM3BC6	TM3BC5	TM3BC4	TM3BC3	TM3BC2	TM3BC1	TM3BC0	108	
		Binary counter 3									
X'3F64'	TM4BCL	TM4BCL7	TM4BCL6	TM4BCL5	TM4BCL4	TM4BCL3	TM4BCL2	TM4BCL1	TM4BCL0	109	
		Binary counter 4 (lower 8 bits)									
X'3F65'	TM4BCH	TM4BCH7	TM4BCH6	TM4BCH5	TM4BCH4	TM4BCH3	TM4BCH2	TM4BCH1	TM4BCH0	109	
		Binary counter 4 (upper 8 bits)									
X'3F66'	TM4ICL	TM4ICL7	TM4ICL6	TM4ICL5	TM4ICL4	TM4ICL3	TM4ICL2	TM4ICL1	TM4ICL0	110	
		Input capture register (lower 8 bits)									
X'3F67'	TM4ICH	TM4ICH7	TM4ICH6	TM4ICH5	TM4ICH4	TM4ICH3	TM4ICH2	TM4ICH1	TM4ICH0	110	
		Input capture register (upper 8 bits)									
X'3F68'	TM5BC	TM5BC7	TM5BC6	TM5BC5	TM5BC4	TM5BC3	TM5BC2	TM5BC1	TM5BC0	110	
		Binary counter 5									
X'3F70'	TM0OC	TM0OC7	TM0OC6	TM0OC5	TM0OC4	TM0OC3	TM0OC2	TM0OC1	TM0OC0	107	
		Compare register 0									
X'3F71'	TM1OC	TM1OC7	TM1OC6	TM1OC5	TM1OC4	TM1OC3	TM1OC2	TM1OC1	TM1OC0	107	
		Compare register 1									
X'3F72'	TM2OC	TM2OC7	TM2OC6	TM2OC5	TM2OC4	TM2OC3	TM2OC2	TM2OC1	TM2OC0	108	
		Compare register 2									
X'3F73'	TM3OC	TM3OC7	TM3OC6	TM3OC5	TM3OC4	TM3OC3	TM3OC2	TM3OC1	TM3OC0	108	
		Compare register 3									
X'3F74'	TM4OCL	TM4OCL7	TM4OCL6	TM4OCL5	TM4OCL4	TM4OCL3	TM4OCL2	TM4OCL1	TM4OCL0	109	
		Compare register 4 (lower 8 bits)									
X'3F75'	TM4OCH	TM4OCH7	TM4OCH6	TM4OCH5	TM4OCH4	TM4OCH3	TM4OCH2	TM4OCH1	TM4OCH0	109	
		Compare register 4 (upper 8 bits)									
X'3F78'	TM5OC	TM5OC7	TM5OC6	TM5OC5	TM5OC4	TM5OC3	TM5OC2	TM5OC1	TM5OC0	110	
		Compare register 5									
X'3F80'	TM0MD				TM0EN	TM0PWN	TM0CK2	TM0CK1	TM0CK0	111	
					Controls counting	Selects operation mode	Selects clock source				
X'3F81'	TM1MD				TM1EN	TM1PWN	TM1CK2	TM1CK1	TM1CK0	112	
					Controls counting	Selects P11 output during TM0PWN operation	Selects clock source				
X'3F82'	TM2MD				TM2EN	TM2PWN	TM2CK2	TM2CK1	TM2CK0	113	
					Controls counting	Selects operation mode	Selects clock source				
X'3F83'	TM3MD				TM3EN	TM3PWN	TM3CK2	TM3CK1	TM3CK0	114	
					Controls counting	Selects P13 output during TM2PWN operation	Selects clock source				
X'3F84'	TM4MD			TM4EN	TM4PWN	T4ICTS1	T4ICTS0	TM4CK2	TM4CK1	TM4CK0	115
				Controls counting	Selects operation mode	Selects input capture trigger		Selects clock source			
X'3F88'	TM5MD	TM5CLRS	TM5IR2	TM5IR1	TM5IR0	TM5CK3	TM5CK2	TM5CK1	TM5CK0	116	
		Selects binary counter 5 to be cleared	Selects time base timer interrupt period			Timer 5 Selects clock source			Selects time base timer clock source		

Summary of Special Function Registers (5/6)

Address	Register	Bit Symbol								Reference Page
		Bit 7	Bit 6	Bit 5	Bit 4	Bit 3	Bit 2	Bit 1	Bit 0	
X'3F89'	RMCTR				TM0RM Selects P10 output	RMOEN Enables remote control carrier output	Must be set to "0"	RMDTY0 Selects duty of remote control carrier output	RMBTMS Selects base timer of remote control carrier	119
X'3F8A'	NFCTR			NF1CK1 Selects IRQ1 noise filter sampling period	NF1CK0 Selects IRQ1 noise filter sampling period	NF1EN Sets IRQ1 noise filter operation	NF0CK1 Selects IRQ0 noise filter sampling period	NF0CK0 Selects IRQ0 noise filter sampling period	NF0EN Sets IRQ0 noise filter operation	171
X'3F90'	ANCTR0	ANSH1 Sets sample and hold time	ANSH0	ANCK1 Selects A/D conversion clock	ANCK0	ANLADE Controls A/D ladder resistors	ANCHS2 Selects analog input	ANCHS1	ANCHS0	161
X'3F91'	ANCTR1	ANST A/D conversion status								162
X'3F92'	ANBUF0	ANBUF07 A/D buffer 0	ANBUF06							163
X'3F93'	ANBUF1	ANBUF17 A/D buffer 1	ANBUF16	ANBUF15	ANBUF14	ANBUF13	ANBUF12	ANBUF11	ANBUF10	163
X'3FA0'	ATMD	ATEXT Selects ATC external connection	ATEN Enables ATC transfer	ATWID Selects ATC transfer unit	ATDIR Selects ATC transfer direction	ATINC Selects ATTAP mode	ATIR2 Transfer activation interrupt selection	ATIR1	ATIR0	179
X'3FA1'	ATCNT	ATCNT7	ATCNT6	ATCNT5	ATCNT4	ATCNT3	ATCNT2	ATCNT1	ATCNT0	180
X'3FA2'	ATTAPL	ATTAP7	ATTAP6	ATTAP5	ATTAP4	ATTAP3	ATTAP2	ATTAP1	ATTAP0	181
X'3FA3'	ATTAPH	ATTAP15	ATTAP14	ATTAP13	ATTAP12	ATTAP11	ATTAP10	ATTAP9	ATTAP8	181
X'3FA4'	ATIAP	ATIAP7	ATIAP6	ATIAP5	ATIAP4	ATIAP3	ATIAP2	ATIAP1	ATIAP0	181
X'3FE0'	Disable to use									—
X'3FE1'	NMICH						WDIR Watchdog interrupt request flag			39
X'3FE2'	IRQ0ICR	IRQ0LV1 Interrupt level flag for external interrupt	IRQ0LV0 External interrupt valid edge flag	REDG0 External interrupt valid edge flag			IRQ0IE Interrupt enable flag	IRQ0IR Interrupt request flag		39
X'3FE3'	IRQ1ICR	IRQ1LV1 Interrupt level flag for external interrupt	IRQ1LV0 External interrupt valid edge flag	REDG1 External interrupt valid edge flag			IRQ1IE Interrupt enable flag	IRQ1IR Interrupt request flag		39
X'3FE4'	TM0ICR	TM0LV1 Interrupt level flag for timer 0 interrupt	TM0LV0				TM0IE Interrupt enable flag	TM0IR Interrupt request flag		40
X'3FE5'	TM1ICR	TM1LV1 Interrupt level flag for timer 1 interrupt	TM1LV0				TM1IE Interrupt enable flag	TM1IR Interrupt request flag		40
X'3FE6'	TM2ICR	TM2LV1 Interrupt level flag for timer 2 interrupt	TM2LV0				TM2IE Interrupt enable flag	TM2IR Interrupt request flag		40
X'3FE7'	TBICR	TBLV1 Interrupt level flag for time base interrupt	TBLV0				TBIE Interrupt enable flag	TBIR Interrupt request flag		40
X'3FE8'	SC0ICR	SC0LV1 Interrupt level flag for serial 0 interrupt	SC0LV0				SC0IE Interrupt enable flag	SC0IR Interrupt request flag		40
X'3FE9'	ATCICR	ATCLV1 Interrupt level flag for data transfer interrupt	ATCLV0				ATC Interrupt enable flag	ATC Interrupt request flag		40

Appendix: Overview of MN101CP01D Internal EPROM

The MN101CP01D microcomputer replaces the mask ROM of the MN101C01* with an electronically programmable 64-KB EPROM.

Because the MN101CP01DAQ is sealed in plastic, once data is written to the internal PROM it cannot be erased. Because the MN101CP01DAQ is sealed in a ceramic package that has a window, written data can be erased by illumination with ultraviolet light.

Both the plastic and ceramic packages use a 80-pin flat package.

Setting the MN101CP01D to EPROM mode, halts microcomputer functions, and the internal EPROM can be programmed. Refer to the EPROM mode pin diagram in figure 1.

The specifications for writing to the internal EPROM are the same as for a general-purpose 1-megabit EPROM ($V_{pp}=12.5V$, $t_{pw}=0.2ms$). Therefore, by replacing the MN101CP01D's 80-pin socket with a special 32-pin MN101CP01D socket adapter (supplied by Panasonic) having the same configuration as a normal EPROM, a general-purpose EPROM writer can be used to perform read and write operations.

Specific instructions for writing to the internal EPROM with a Panasonic writer are provided in section (2). The internal EPROM can be used to set high-speed or low-speed oscillation start control and the runaway detection period for the MN101CP01D. Details are shown in (3). Precautions are listed in (4). Instructions for erasing data from a window packaged part are provided in (5). The difference between the MN101CP01D (internal EPROM version) and the MN101C01D (mask ROM version) is shown in (6).

(1) Internal EPROM Considerations

- Write #FF data to the #00000~#03FFF memory area.
Use the #04000~#13FFF (64K) memory area as a continuous area.
- If the EPROM is to be programmed with a PROM writer, be sure to verify that the socket adapter and product are properly mounted. If not properly mounted, the product may be damaged.
- The MN101CP01D programming voltage is specified as 12.5V. Therefore, writing a program with a 21V system specification will damage the product. If a PROM writer will be used for programming, set the specifications for a general-purpose 1-megabit EPROM ($V_{pp}=12.5V$, $tpw=0.2ms$).



This product does not contain an ID code such as "Silicon Signature" or "Intelligent Identifier" for the writer's auto-device selection command. Consequently, the auto-device selection command should never be used with this product, as the device might be damaged.

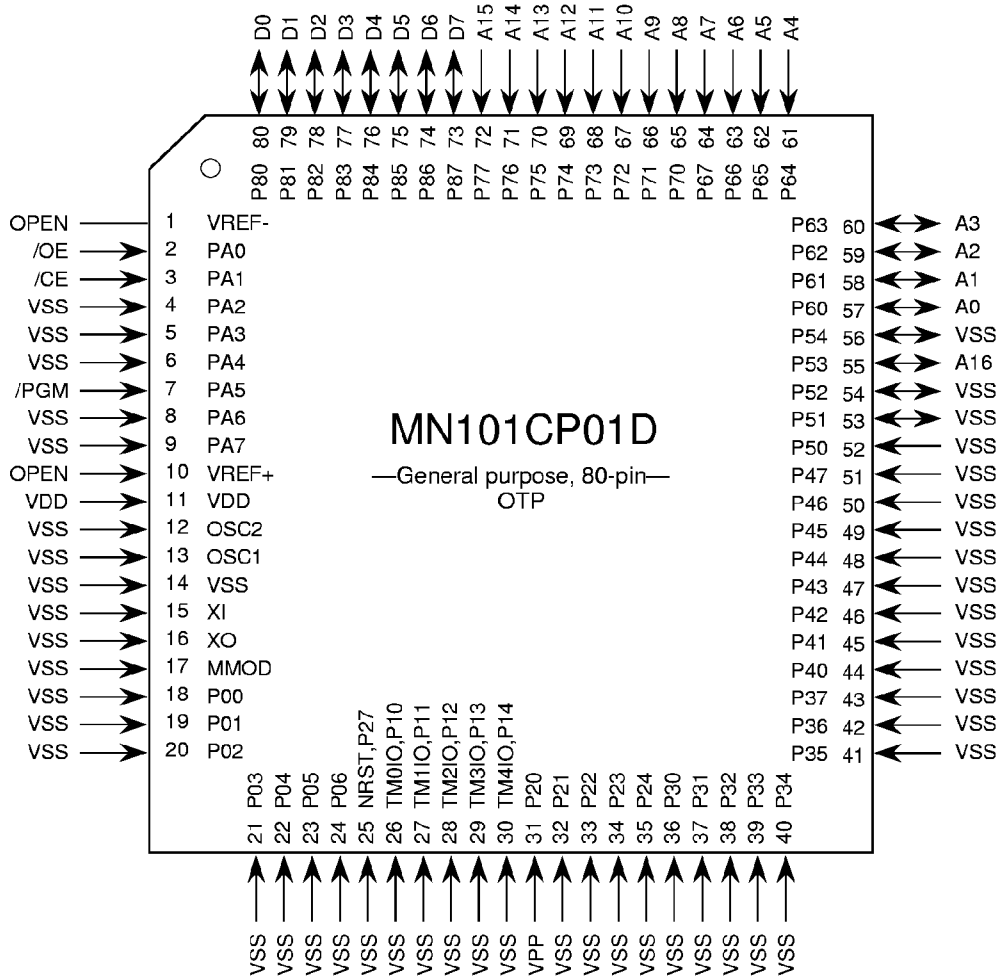

Figure 1 MN101CP01D EPROM Write Adapter Pin Diagram

(2) Writing to the Internal EPROM

• When using the PanaXIPW writer

OTP adapter setup method

Align the  and connect the OTP and general-purpose sections.

Align the  and the IPW ROM insertion direction and insert.

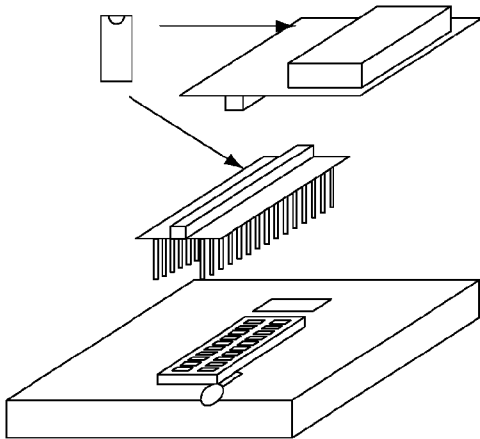

IPW settings (after normal IPW activation)

Priority	
Device selection (F1)	
Type	Select EPROM.
Manufacturer name selection	Select HITACHI.
Device name selection	Select HN27C101AG.
Write sequence	Select 1-Byte Program.
After selecting, implement.	

Loading file: Load (F9)	
File name	
Start address	****

Write: Write (F3)	
ROM start address	00004000
ROM end address	00013FFF
Memory start address	00004000
Erase check selection	Perform erase check.
After selecting, perform the write operation.	

An additional method.	
DEVICE selection (F1)	
Type	Select OTCPU.
Manufacturer name selection	*****
Device name selection	Select MN101CPXXX.
Write sequence	Select 1-Byte Program.
After selecting, implement.	

If a write operation is to be performed, use the same settings as above.

• When using the PanaXEPP writer

OTP adapter setup method

Align the  and connect the OTP and general-purpose sections.

Align the  and the EPP ROM insertion direction and insert.

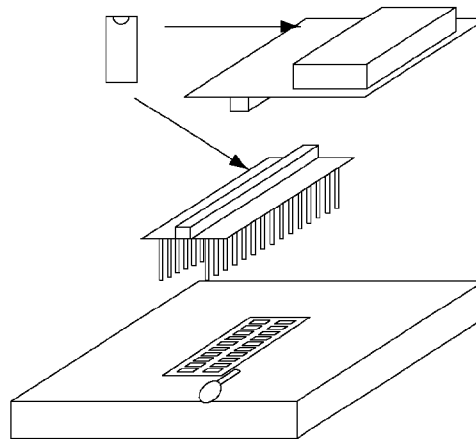

EPP settings (after normal EPP activation)

- | | |
|-------------------------|------------------------------------|
| Menu screen | 1. Select DEVICE&MODE setup screen |
| | ↓ |
| Device selection screen | 6. Select 1 MB |
| | ↓ |
| Mode selection screen | 7. Select HITACHI quick |
| | ↓ |
| | Return to main menu |
| | ↓ |
| Menu screen | 2. Select write setup screen |

File Name: user file name
 ROM Start address: 4000 or 0
 File Start address: 4000 or 0
 Byte: 10000 or actual ROM size

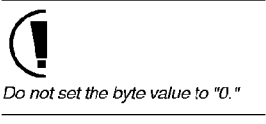

After setting up, perform the write operation.

(3) EPROM option bits

The MN101CP01D can use bits 0~2 of address #1FF02 of the internal EPROM to set high-speed or low-speed oscillation start control and the runaway detection (watch-dog) period.

The address of this option is in an area that does not exist in the ROM version.

The option bit specifications are listed in table 1.

Table 1 Option Bit Specifications

Option Bit	Address	Setting Item	Program Contents
OPT0	x'1FF02' (bit0)	Oscillation mode	1: Type A 0: Type B
OPT1 OPT2	x'1FF02' (bit1) x'1FF02' (bit2)	Runaway detection period	bit1 bit2 1 1: $f_s/2^{20}$ 0 1: $f_s/2^{18}$ 0 0: $f_s/2^{16}$

Type A: In the NORMAL mode, operation begins from the reset cycle.

Type B: In the SLOW mode, operation begins from the reset cycle.



Options are set in the area of #1FF00~#1FFFF. With the exception of the 3 option bits, set the data to "1". Verify the settings to make sure there are no errors.

(4) Cautions

- The MN101CP01D differs from the MN101C01* in some of its electrical characteristics. The user should be aware of these differences.
- To prevent data from being erased by ultraviolet light after a program is written, affix seals impermeable to UV rays to the glass sections at the top and side sections of the CPU.
- From the time after a program is written until just before mounting, storage at a high temperature is recommended.

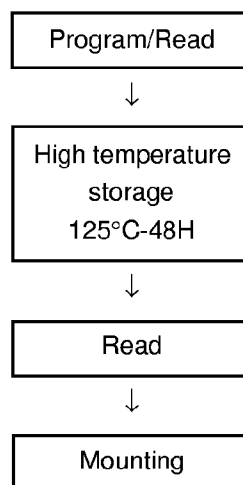

- Due to device characteristics of the OTP version, a writing test cannot be performed on all bits. Therefore, storage of the written data cannot be fully guaranteed in some cases.
- Verify that VCC power supply (6V) is connected before applying the VPP power supply (12.5V). Disconnect the VPP supply before disconnecting the VCC supply.
- VPP should never exceed 13.5V including overshoot.
- If a device is removed while a VPP of +12.5V is applied, device reliability may be damaged.
- At CE=VIL, do not change VPP from VIL to +12.5V or from +12.5V to VIL.

(5) Erasing data in windowed packages

In an internal EPROM with windowed packaging, data is erased ("0"→"1") when UV light at 2537 Å permeates the window to irradiate the chip.

The recommended exposure is 10W•s/cm². This coverage can be achieved by using a commercial UV lamp positioned 2~3 cm above the package for 15~20 minutes (when the illumination intensity of the package surface is 12000μW/cm²). Remove any filters attached to the lamp. By installing a mirrored reflector plate in the lamp, illumination intensity will increase by a factor of 1.4~1.8, decreasing the erasure time.

If the window becomes dirty with oil, adhesive, etc., UV light permeability will decrease, causing the erasure time to increase considerably. If this happens, clean with alcohol or another solvent that will not harm the package. The recommended above provides sufficient leeway, with several times the amount of time it takes to erase all the bits. However, this value will reliably erase data over all temperature and voltage ranges, and should not be altered. The level of illumination should be regularly checked and the lamp operation verified.

Erasure begins when the EPROM is exposed to light with a wavelength shorter than 4000 Å. Since fluorescent light and sunlight have wavelengths in this range, exposure to these light sources for extended periods of time could cause inadvertent erasure. To prevent this, cover the window with an opaque label.

Data is not erased at wavelengths. However, because of typical semiconductor characteristics, the circuit may malfunction if the chip is exposed to an extremely high illumination intensity. The chip will operate normally if this exposure is stopped. However, for areas where it is continuous, take necessary precautions.

(6) MN101CP01D characteristics

The MN101C01D (mask ROM version) and the MN101CP01D (internal EPROM version), both 80-pin, 8-bit microcomputers with internal LCD drivers, have the following differences.

	MN101C01D (ROM version)	MN101CP01D (EPROM version)
ROM size	65336 bytes	<u>65336 bytes</u>
RAM size	2048 bytes	<u>2048 bytes</u>
Ambient operating temp.	-40~85°C	<u>-20~70°C</u>
Operating voltage	4.5~5.5V (for 0.1μS/20MHz) 2.7~5.5V (for 0.25μS/8MHz) 2.0~5.5V (for 1.00μS/2MHz)	4.5~5.5V (for 0.1μS/20MHz) 2.7~5.5V (for 0.25μS/8MHz) <u>2.7~5.5V</u> (for 1.00μS/2MHz)
Pin DC characteristics	Output current, input current, input determination level Both ROM and EPROM versions were designed with the same product specifications.	
Pull-up resistor connection	Pull-up via software	Pull-up via software
Options for high/low speed oscillation start control, run-away detection period setting	Mask option	<u>EPROM option*</u>

*EPROM data is used as the option data.

There are no other functional differences.

MN101C01D
LSI User's Manual

JANUARY,1997 Version 2.1

Issued by Matsushita Electronics Corporation Micro Computer SE Division
c Matsushita Electronics Corporation